

NP267192A

TOL	+/-
A	.06
B	.12
C	.18
D	.25

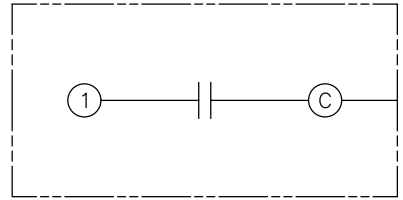
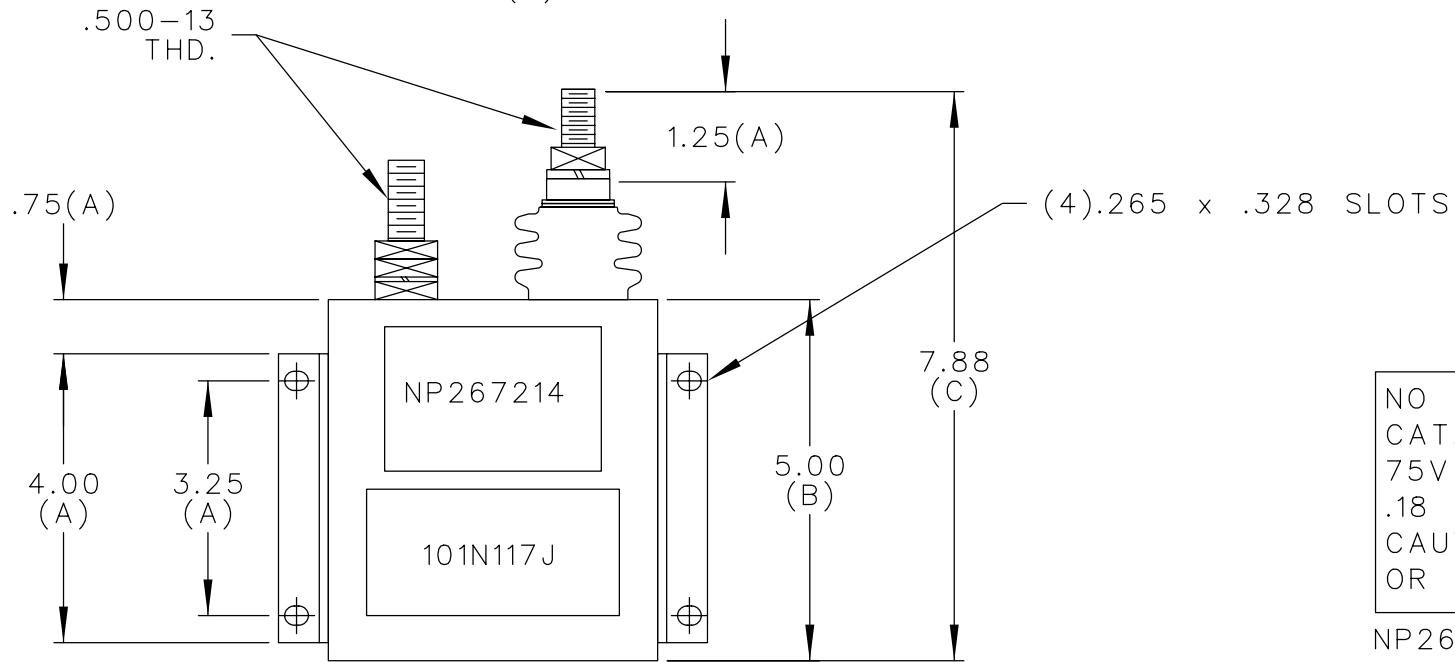

SCHEMATIC DIAGRAM - 101

NO INTERNAL DISCH RESISTORS
 CAT. 16L0030WH3 SN
 75V 10KHz 7.4KVAR 21uF
 .18 GALS. COMBUSTIBLE LIQUID
 CAUTION! BEFORE INSTALLING
 OR OPERATING READ GEH-2743

NP267214

MAX. TERMINAL
 TIGHTENING TORQUE
 15 FT-LBS

NP267192A

	CAPACITOR & POWER PROTECTION FORT EDWARD, N.Y., U.S.A.		SIZE A	OUTLINE 16L0030WH3		DISTR TO
	DRAWN E.McGINN	SEPT. 24, 1996	SCALE			
ISSUED	09-25-96		SCALE	SHEET 2		DISTR TO