

TOL	+/-
A	.06
B	.12
C	.18
D	.50
E	.04
BUSH, DIA	1.75[4](B)

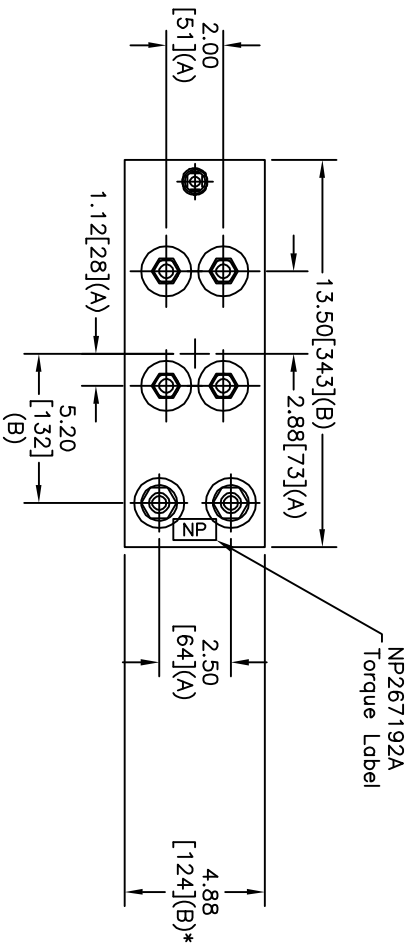

TERM	UF
1	194
2	194
3	194
4	194

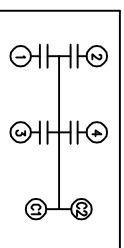
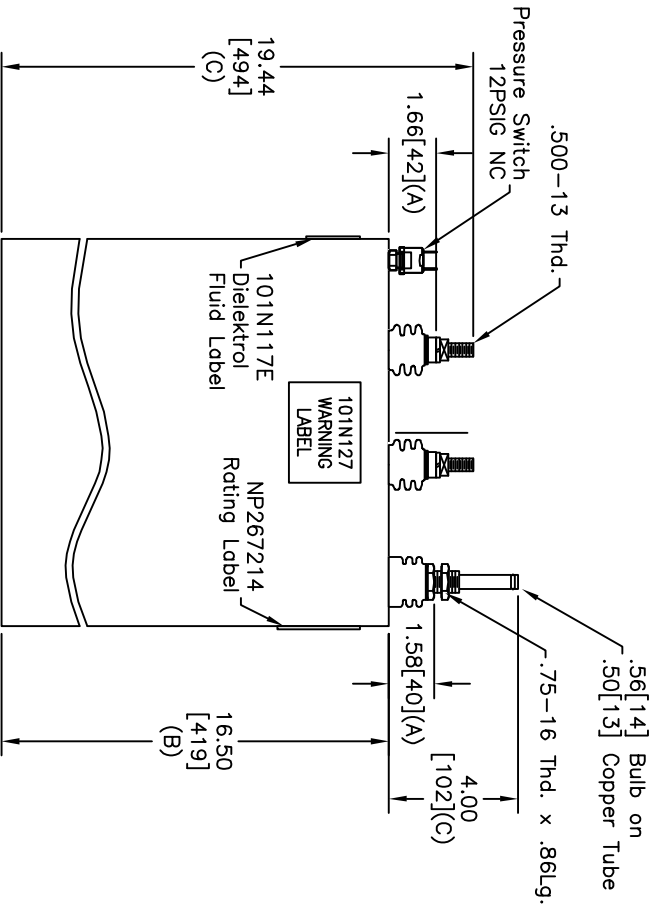

NO INTERNAL DISCH RESISTORS
 CAT. 19L0848TH2 SN
 900VDC 780UF 1200AMPS
 4x194UF/TAP
 2.23 GAL. COMBUSTIBLE LIQUID
 CAUTION! BEFORE INSTALLING OR
 OPERATING READ GEH-2733+2739
 MADE IN USA NP267214

* UP TO +.50[13]
 CASE BULGE

MAX. TERMINAL
 TIGHTENING TORQUE
 15 FT-LBS.
 NP267192A

SIZE	DWG NO	SHT	REV
A	19L0848TH2	2	3
REV	DESCRIPTION	DATE	APPROVED
3	UPDATE PN	8/8/2007	BTR

GE ENERGY FORT EDWARD, N.Y., U.S.A.		SIZE	A
DRAWN W.DEGROFF	DATE 5/13/1991	Est Weight 52 lbs.	
ISSUED	DATE 5/16/1991	SCALE	
<h1>OUTLINE</h1> <h2>19L0848TH2</h2>		SHEET 2	CONT 3

DISTR. TO