

SIZE A	DWG NO 19L1232WH4	SHT 2	REV
REV	DESCRIPTION	DATE	APPROVED

TOL	+/-	BUSH. DIA.
A	.06	1.75[44](B)
B	.12	
C	.18	
D	.50	
E	.04	

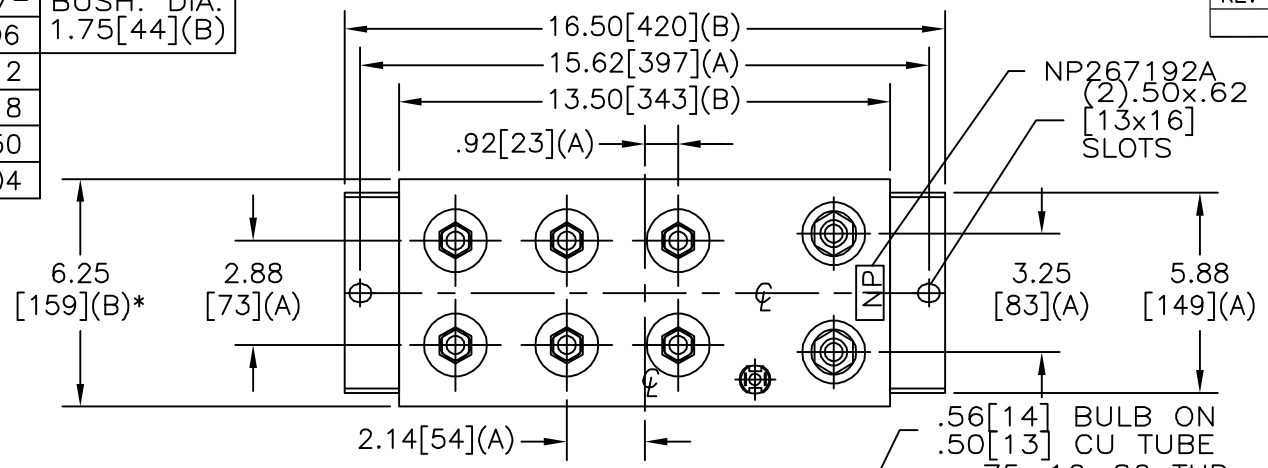

TERM	uF	kVAR
1	51.85	316.67
2	51.85	316.67
3	51.85	316.67
4	51.85	316.67
5	51.85	316.67
6	51.85	316.67

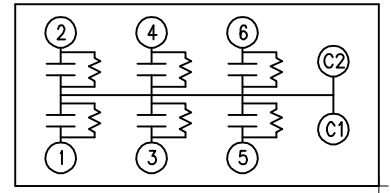

SCHMATIC DIAGRAM - 617

WITH INTERNAL DISCH RESISTORS
 CAT. 19L1232WH4 SN
 1900KVAR 1800V 300HZ 1PH
 6x51.85 UF/TAP
 3.28 GAL. COMBUSTIBLE LIQUID
 CAUTION! BEFORE INSTALLING OR
 OPERATING READ GEH-2733

NP267214

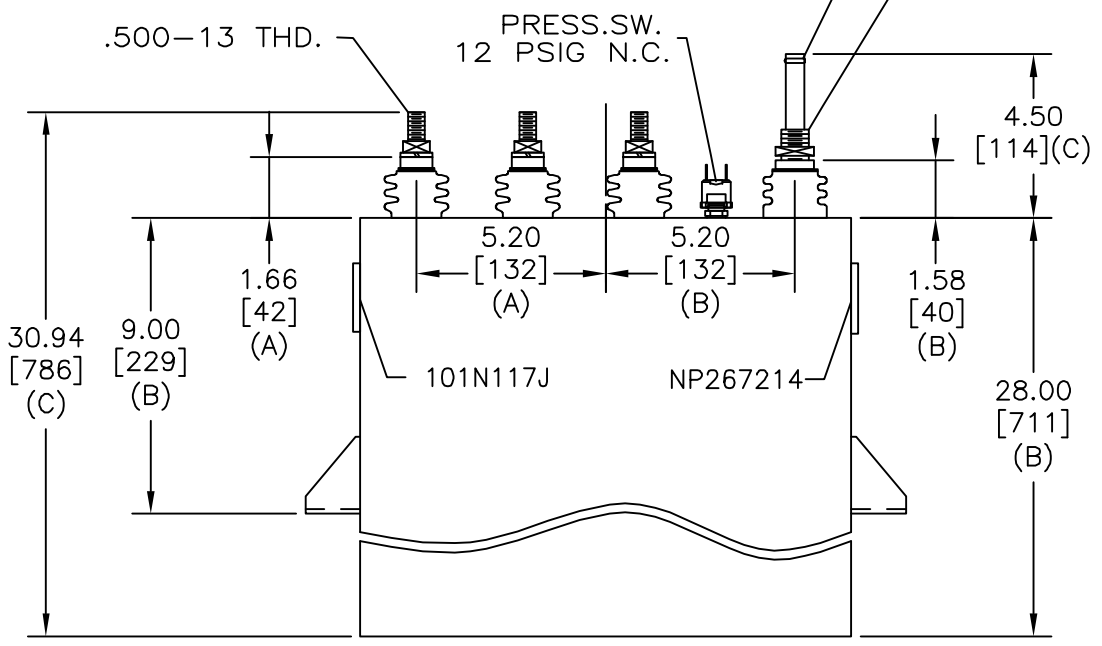

* UP TO +.50[13]
CASE BULGE

MAX. TERMINAL
TIGHTENING TORQUE
15 FT-LBS

NP267192A

INDUSTRIAL SYSTEMS FORT EDWARD, N.Y., U.S.A.	SIZE A	EST WEIGHT 112 LBS	OUTLINE 19L1232WH4
	DRAWN B. ROSS DATE NOV 13, 2003	SCALE	
ISSUED DATE 11/19/03			

DISTR. TO