

SIZE <b>A</b>	DWG NO. 37F0523331	SH 2	REV
REV		DATE	

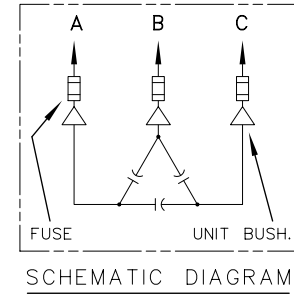
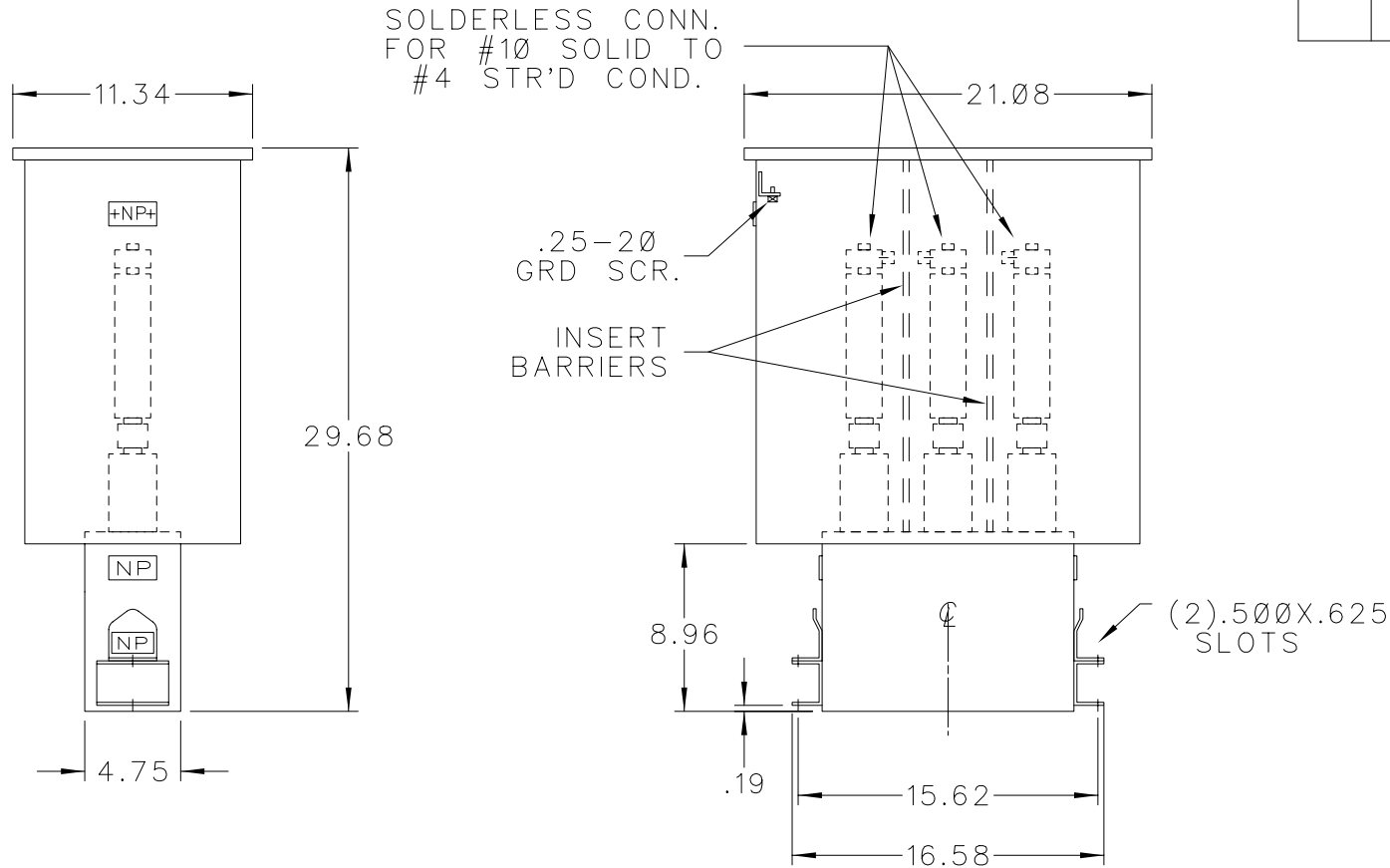

CAT. 37F0523331 SER.NO.  
KVAR 25 VOLT 4160  
Hz 60 PH 3 CONN. DELTA  
CONN. DIAG.

READ INST. GEH-2711

NP220452

NOTE:  
ADD "Ø37" SUFFIX TO  
CATALOG NO. FOR  
CSA LABELED PRODUCT.

GENERAL  ELECTRIC	
CAP. & PWR PROTECTION OPER. LCTN: HUDSON FALLS NY	
DRAWN E. McGINN	OCT. 17, 1991
ISSUED	

SIZE <b>A</b>	APPROX.WT 86 LBS
SCALE	

OUTLINE  
37F0523331

SHEET 2

DISTR TO