

SIZE	DWG NO	SHT	REV
A	SIL202WC59	2	0
REV	DESCRIPTION	DATE	APPROVED
0	New	4/26/2006	

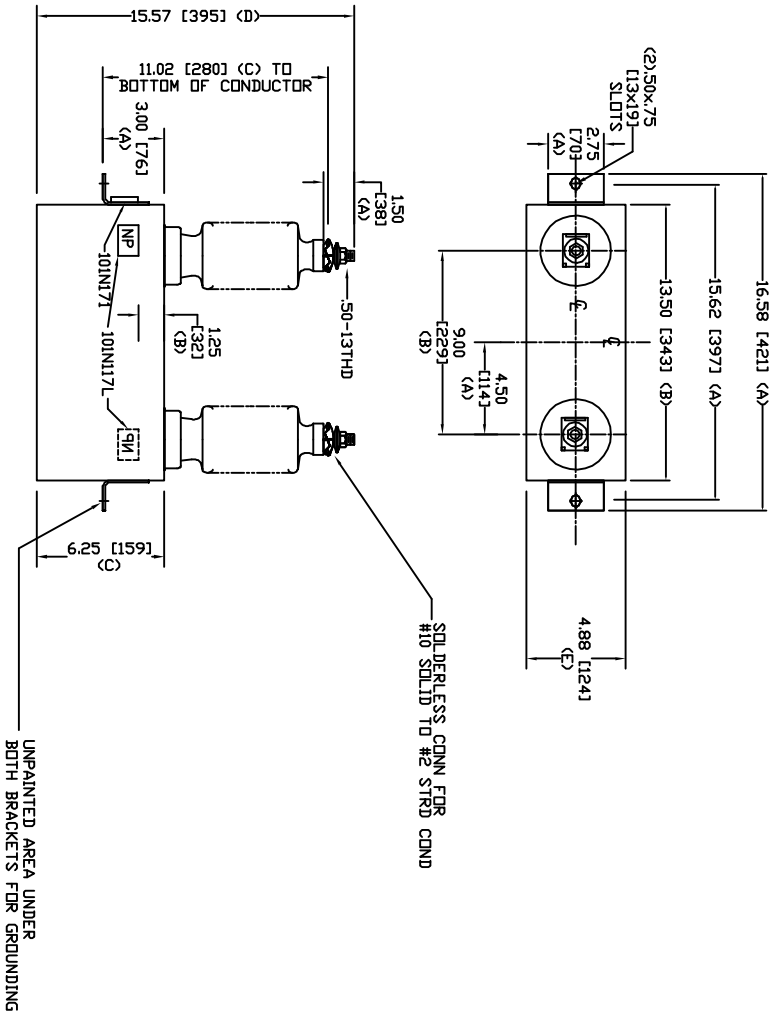

TOL	in.	mm
A	.06	1.5
B	.12	3.0
C	.18	4.6
D	.25	6.4
E	+.5/-1	+13/-25

2770 V 1 PH 95 KV/BIL  
 50 KVAR 60 HZ  
 CAT. SIL202WC59  
 1.09 GAL  
 MFG DATE  
 101N171 READ GEH-2743

<b>INDUSTRIAL SYSTEMS</b> FORT EDWARD, N.Y., U.S.A.		SIZE	A	WEIGHT	20 lbs 9.1 kg	<b>OUTLINE</b> SIL202WC59	
DRAWN	ACAD VBA	SCALE				SHEET	2
ISSUED	RAH	DATE	8/25/2008			CQNT	3