

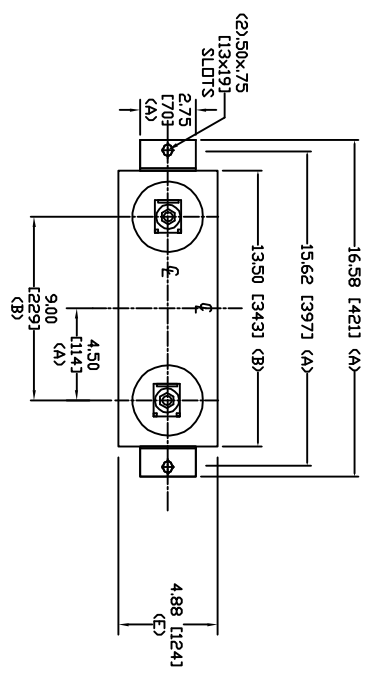

SIZE	DWG NO	SHT	REV
A	S1L225WC60	2	1
REV	DESCRIPTION	DATE	APPROVED
1	New	5/23/2007	

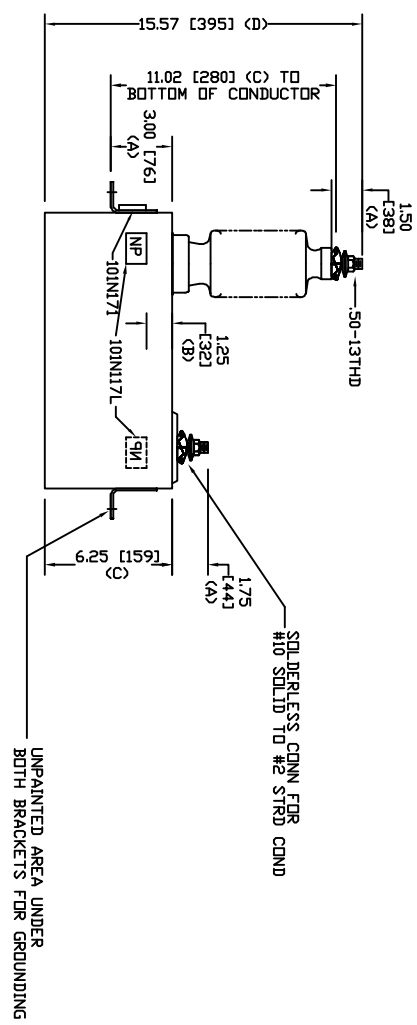

TOL	in.	mm
A	.06	1.5
B	.12	3.0
C	.18	4.6
D	.25	6.4
E	+.5/-1	+13/-25



6640 V 1 PH 95 KV/BIL  
 50 KVAR 60 HZ  
 CAT. S1L225WC60  
 1.03 GAL  
 MFG DATE  
 101N171 READ GEH-2743

**GE ENERGY**  
**FORT EDWARD, N.Y., U.S.A.**

DRAWN	ACAD VBA	DATE	4/1/2010
ISSUED	RAH	DATE	4/1/2010

SIZE **A** WEIGHT 20.4 lbs 9.3 kg  
 SCALE  
**OUTLINE**  
**S1L225WC60**  
 SHEET 2 CNT 3