

SIZE	DWG. NO.	SHT	REV
A	SIL235WC60	2	0
REV	DESCRIPTION	DATE	APPROVED
0	New	7/12/2006	

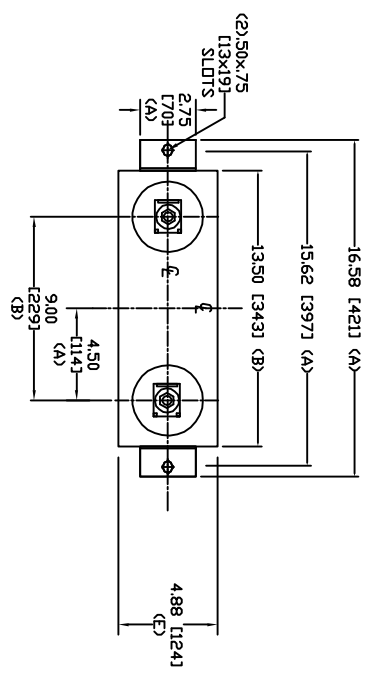

TOL	in.	mm
A	.06	1.5
B	.12	3.0
C	.18	4.6
D	.25	6.4
E	+5/-1	+13/-25

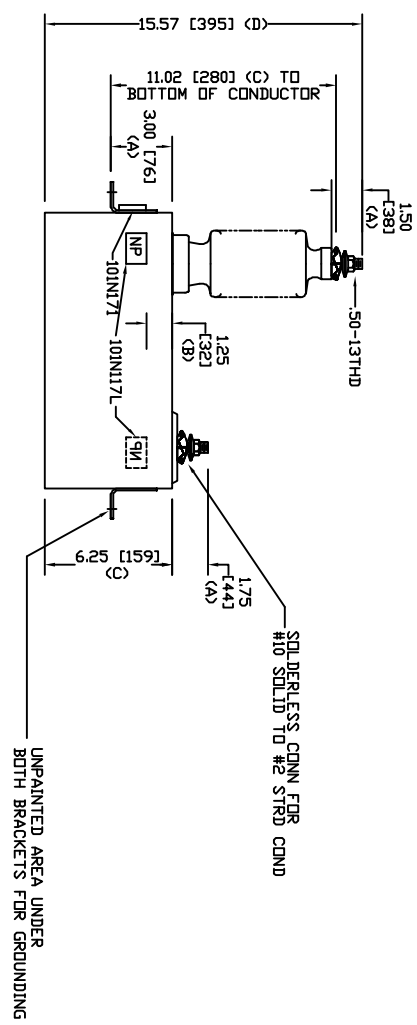

8320 V 1 PH 95 KV/BIL
 50 KVAR
 CAT. SIL235WC60
 1.03 GAL
 MFG DATE
 101N171 READ GEH-2743



GE ENERGY
 FORT EDWARD, N.Y., U.S.A.

DRAWN	ACAD VBA	DATE	4/3/2010
ISSUED	RAH	DATE	4/3/2010

SIZE	WEIGHT	DUTLINE
A	20.6 lbs 9.4 kg	SIL235WC60
SCALE		SHEET 2
		CGNT 3