

SIZE	DWG. NO.	SHT	REV
A	58L107WC60	2	0
REV	DESCRIPTION	DATE	APPROVED
0	New	5/9/2005	

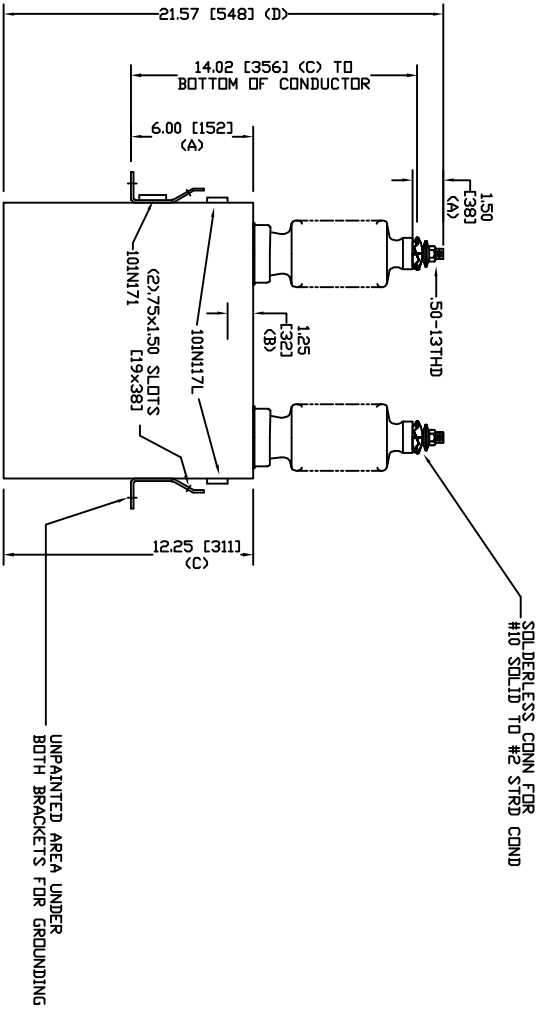
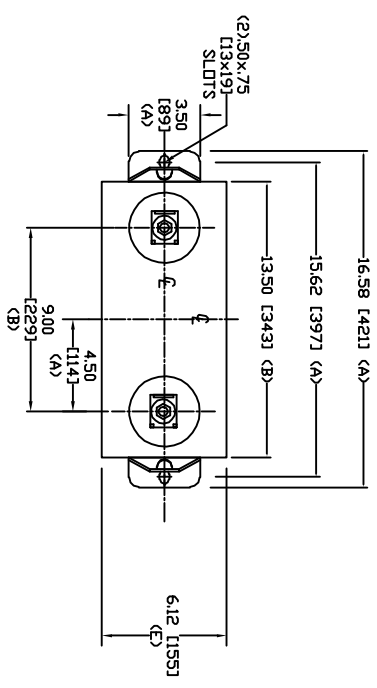

TOL	In.	mm
A	.06	1.5
B	.12	3.0
C	.18	4.6
D	.25	6.4
E	+.5/-1	+13/-25

7620 V 1 PH 95 KV/BIL  
 200 KVAR 60 Hz  
 CAT. 58L107WC60  
 1.87 GAL  
 MFG DATE  
 100N171 READ GEH-2743

<b>INDUSTRIAL SYSTEMS</b> FORT EDWARD, N.Y., U.S.A.		SIZE	A	WEIGHT	50.4 lbs 22.9 kg	OUTLINE	58L107WC60
DRAWN	ACAD VBA	DATE	7/16/2007	SCALE		SHEET	2
ISSUED	RAH	DATE	7/16/2007			CGNT	3