

SIZE	DWG. NO.	SHT	REV
A	58L126WC60	2	0
REV	DESCRIPTION	DATE	APPROVED
0	New	2/3/2006	

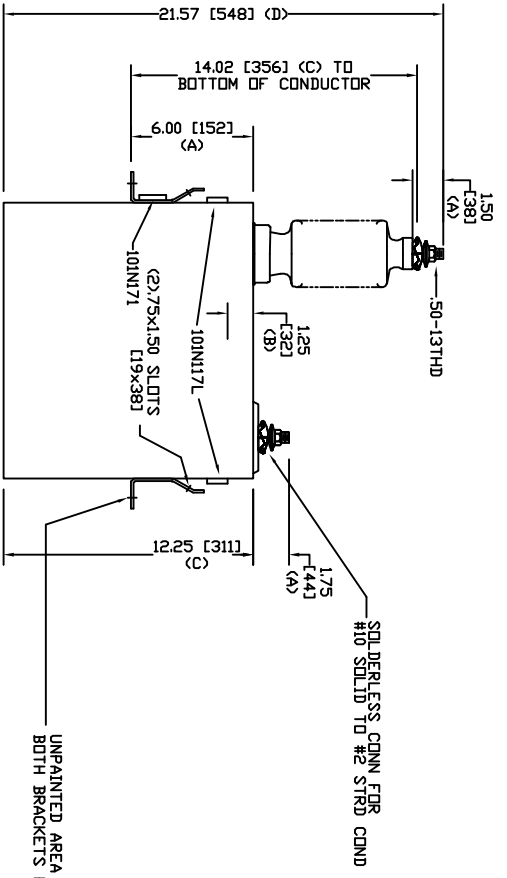
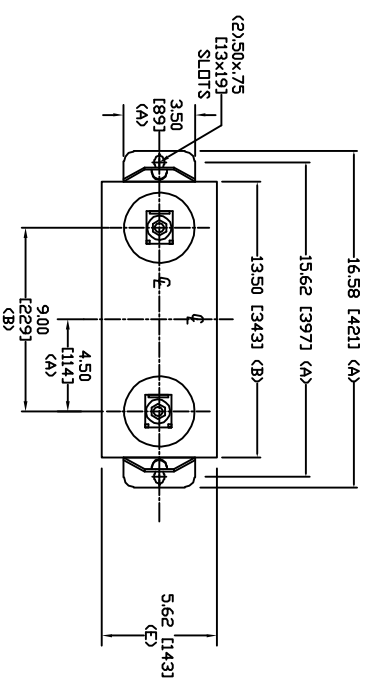

TOL	In.	mm
A	.06	1.5
B	.12	3.0
C	.18	4.6
D	.25	6.4
E	+.5/-1	+13/-25

7200 V 1 PH 95 KVBL
 200 KVAR 60 Hz
 CAT. 58L126WC60
 1.71 GAL
 MFG DATE
 101N171 READ GEH-2743

GE ENERGY FORT EDWARD, N.Y., U.S.A.		SIZE	A
DRAWN	ACAD VBA	DATE	3/15/2000
ISSUED	RAH	DATE	3/15/2000
WEIGHT 43 lbs 19.5 kg		SCALE	
OUTLINE 58L126WC60		SHEET	2
DISTR. TO		CGNT	3