

SIZE A	DWG NO 65L810TY2	SHT 2	REV
REV	DESCRIPTION	DATE	APPROVED

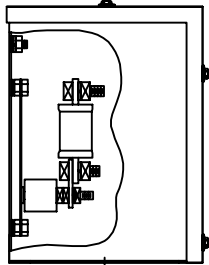
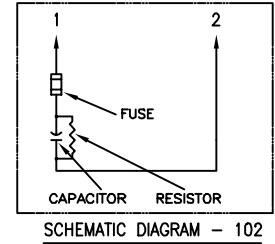
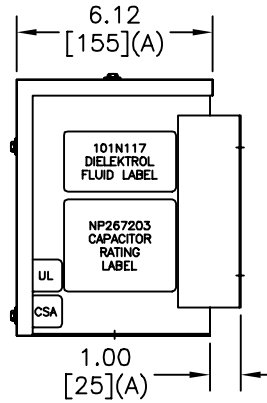
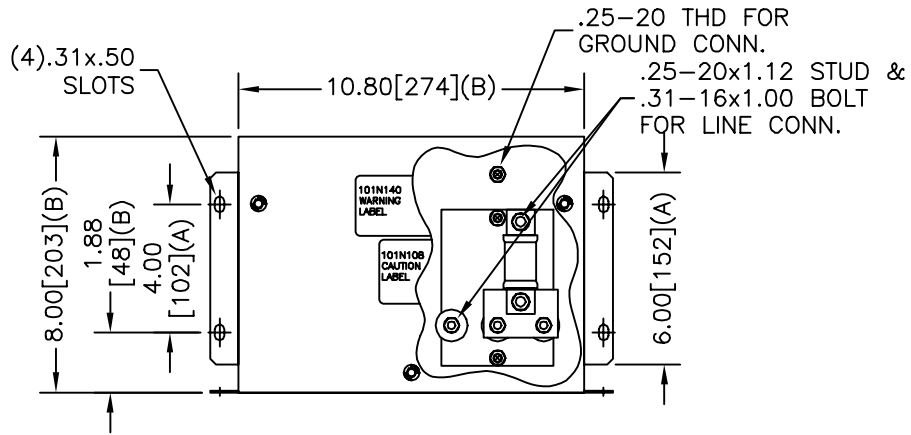
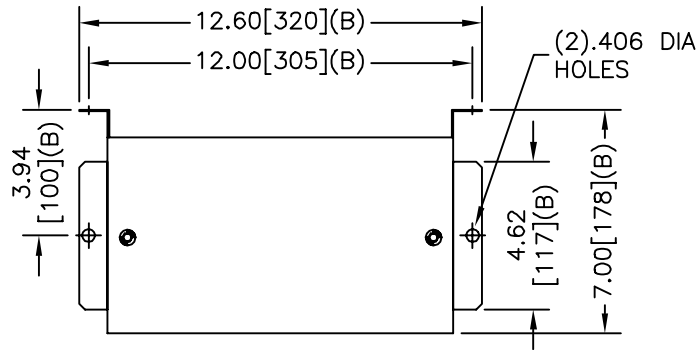

**GE CAPACITOR**

WITH INTERNAL DISCHARGE RESISTORS

CAT 65L810TY2 SN  
 12.5 KVAR 240V 60HZ 1PH

CONTAINS 0.1 GAL. COMBUSTIBLE LIQUID WITH LESS THAN ONE PART PER MILLION PCB ON MFG DATE MM/YYYY  
 CAUTION! BEFORE INSTALLING OR OPERATING READ GEH- 2738

NP267203 FORT EDWARD, N.Y. MADE IN U.S.A.

TOL	+/-
A	.06
B	.12
C	.18
D	.25

INDUSTRIAL SYSTEMS FORT EDWARD, N.Y., U.S.A.		SIZE A
DRAWN B.Ross	DATE 7/29/2003	SCALE
ISSUED	DATE 8/6/2003	

OUTLINE  
65L810TY2

SHEET 2 CONT ON -

DISTR. TO