

REVISIONS			
REV	DESCRIPTION	DATE	APPROVED
1	UPDATE TO AUTOCAD		KS

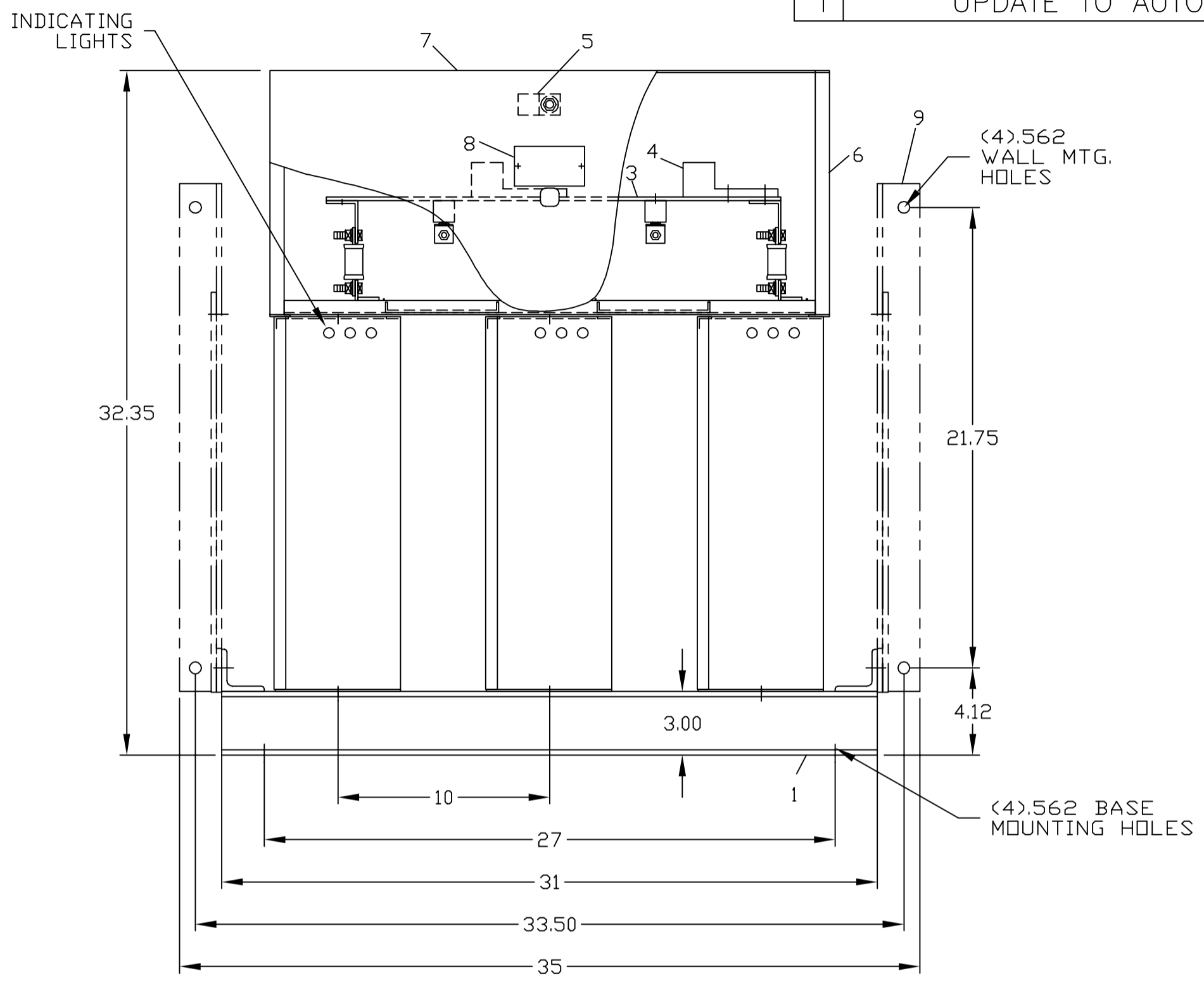

NOMENCLATURE

1. ALUMINUM BASE FRAME
2. CAPACITOR UNIT
3. COPPER BUS BARS
4. LINE TERMINAL - #4/0 TO 600 MCM
5. GROUND TERMINAL - #6AWG TO 250 MCM
6. BUS ENCLOSURE
7. ACCESS COVER
8. RATING NAMEPLATE
9. OPTIONAL FIELD ASSEMBLED WALL MTG. FRAME

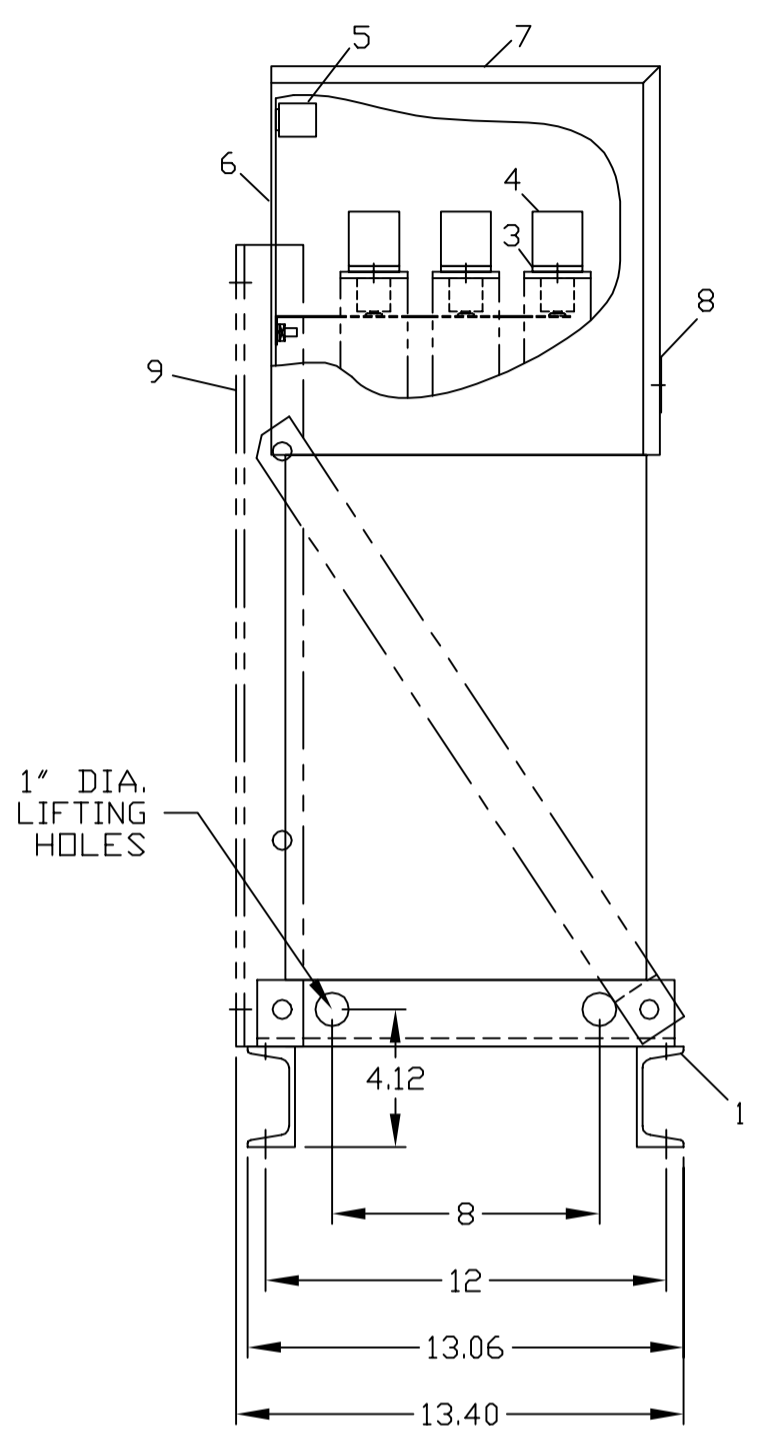
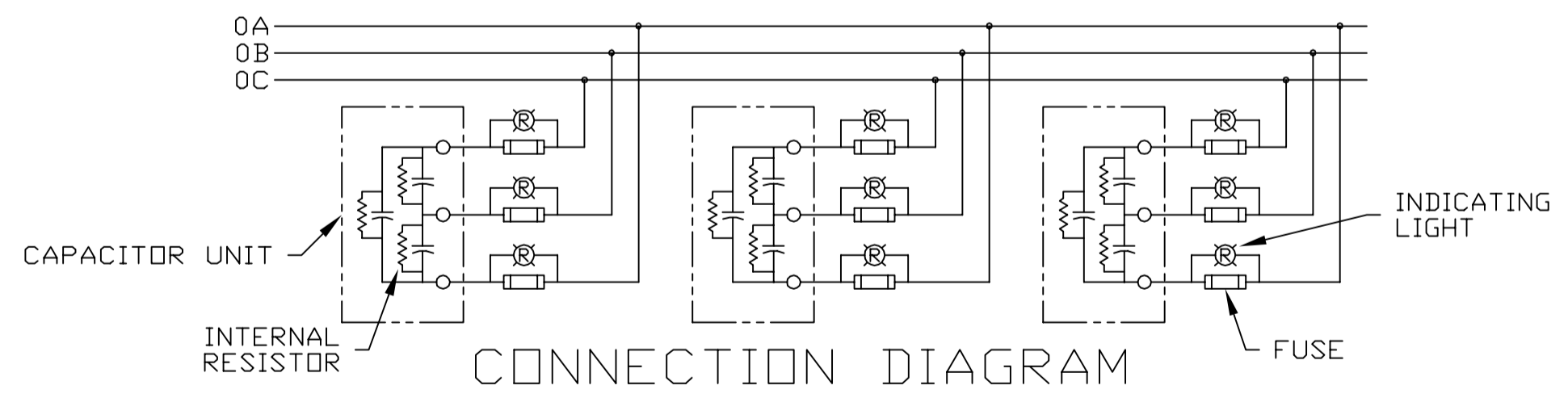

CAT	65L910TQ2	SERNO	
KVAR	85	60Hz	3ph
VOLT	240	DIAG	186C3233FB
		CONN	DELTA

Read instructions: GEH-2728

SIGNATURES		DATE
DRAWN E.McGINN		9/28/92
CHECKED		
ENGR		
ISSUED		9/30/93
CAD SYS. NO.		
AUTOCAD		

INDUSTRIAL SYSTEMS
FORT EDWARD, N.Y., U.S.A.

OUTLINE
65L910TQ2

FIRST MADE FOR:

SIZE	FSCM NO.	DWG NO.	REV
C		65L910TQ2	1
SCALE	SHEET	CONT ON SHT	

413
DISTR TO