

REVISIONS			
REV	DESCRIPTION	DATE	APPROVED
1	UPDATE TO AUTOCAD		EJM

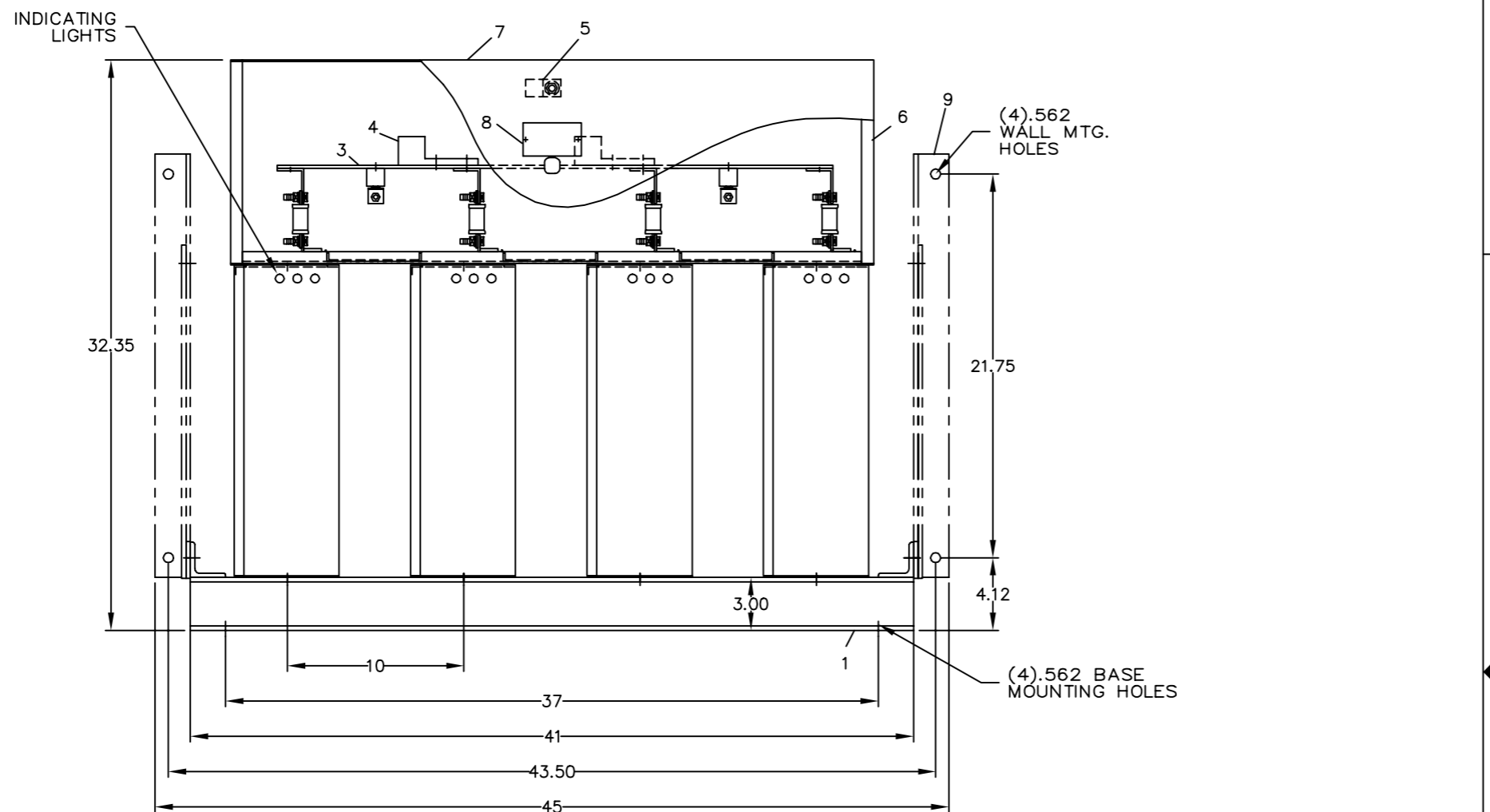

- NOMENCLATURE**
1. ALUMINUM BASE FRAME
 2. CAPACITOR UNIT
 3. COPPER BUS BARS
 4. LINE TERMINAL - #4/0 TO 600 MCM
 5. GROUND TERMINAL - #6AWG TO 250 MCM
 6. BUS ENCLOSURE
 7. ACCESS COVER
 8. RATING NAMEPLATE
 9. OPTIONAL FIELD ASSEMBLED WALL MTG. FRAME

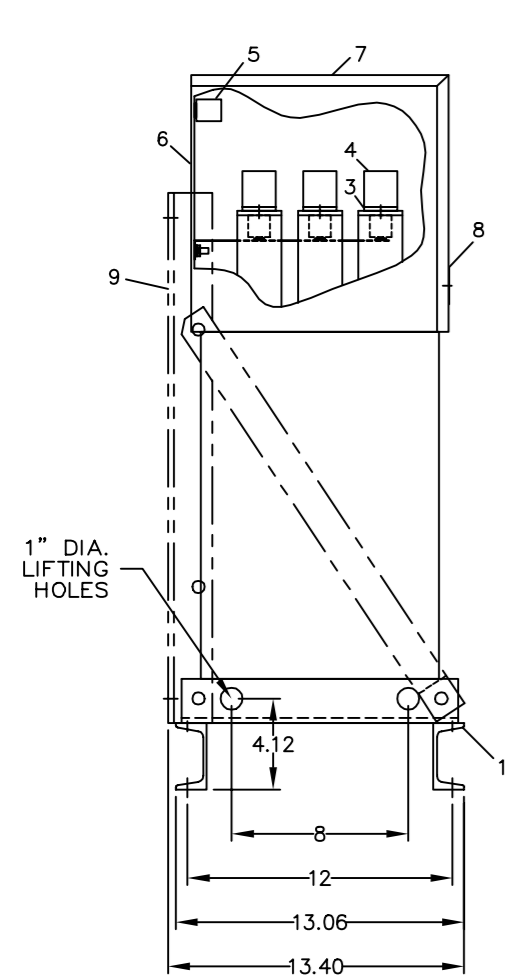
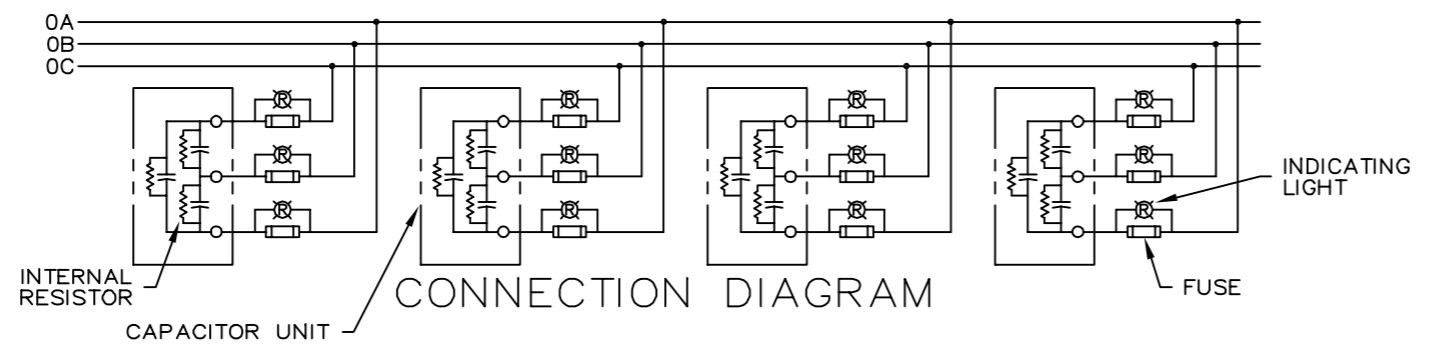

SIGNATURES	DATE
DRAWN E.McGINN	9/30/93
CHECKED	
ENGR	
ISSUED	9/30/93
CAD SYS. NO.	
AUTOCAD	

INDUSTRIAL SYSTEMS
FORT EDWARD, N.Y., U.S.A.

OUTLINE
65L919TQ2

FIRST MADE FOR:

SIZE	FSCM NO.	DWG NO.	REV
C		65L919TQ2	1

SHEET 1 CONT ON SHT -

CAT 65L919TQ2 SERNO
KVAR 150 60Hz 3ph
VOLT 240 DIAG 186C3233GB
CONN DELTA
Read instructions: GEH-2728

413