

SIZE	DWG NO.	SHT	REV	REV
C	65L923TN2	1	1	1
REVISIONS				
REV	DESCRIPTION	DATE	APPROVED	
1	UPDATE TO AUTOCAD		FWL	

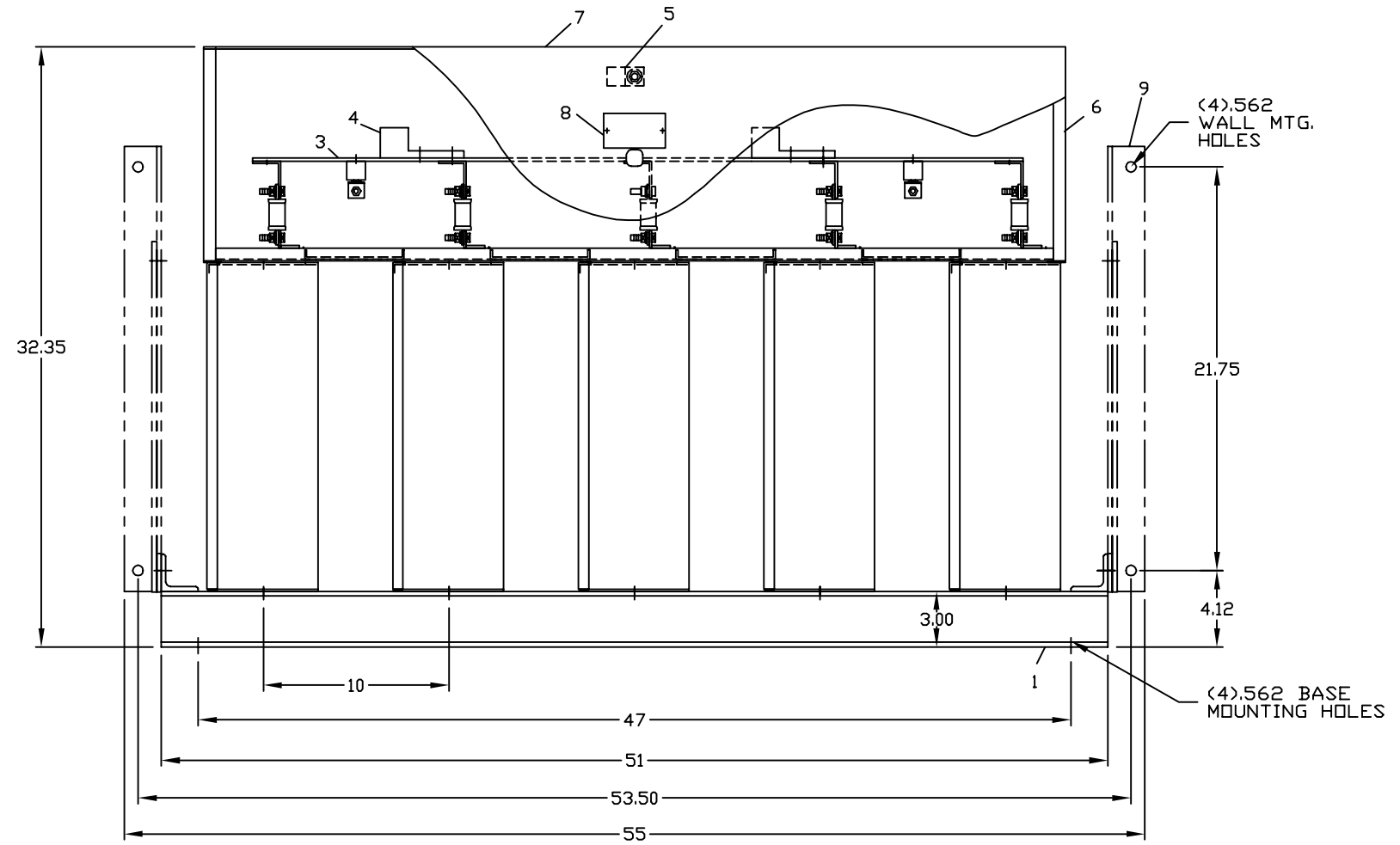

- NOMENCLATURE**
1. ALUMINUM BASE FRAME
 2. CAPACITOR UNIT
 3. COPPER BUS BARS
 4. LINE TERMINAL - #4/0 TO 600 MCM
 5. GROUND TERMINAL - #6AWG TO 250 MCM
 6. BUS ENCLOSURE
 7. ACCESS COVER
 8. RATING NAMEPLATE
 9. OPTIONAL FIELD ASSEMBLED WALL MTG. FRAME

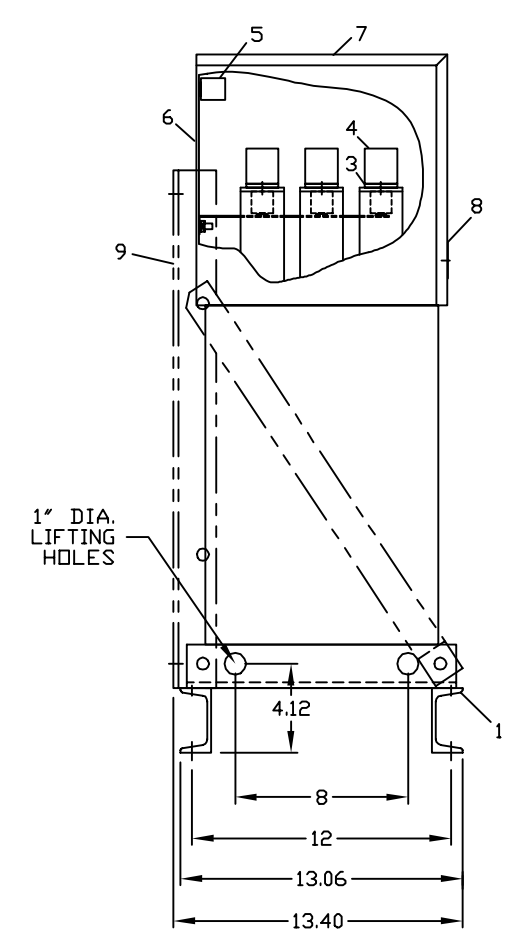
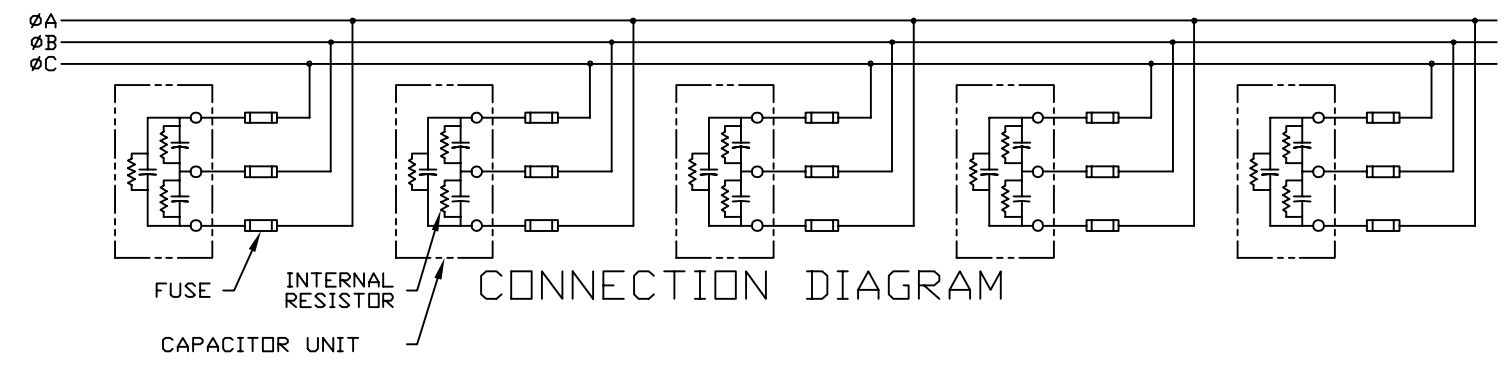

SIGNATURES		DATE		INDUSTRIAL SYSTEMS FORT EDWARD, N.Y., U.S.A. OUTLINE L65 EQUIPMENT	413
DRAWN E.McGINN		10/1/92			
CHECKED					
ENGR					
ISSUED		9/30/93			
FIRST MADE FOR:					
CAD SYS. NO.		SIZE C	FSCM NO.	DWG NO. 65L923TN2	REV 1
AUTOCAD		SCALE		SHEET 1	CONT ON SHT -

CAT 65L923TN2 SERNO
 KVAR 180 60Hz 3ph
 VOLT 240 DIAG 186C3233HD
 CONN DELTA
 Read instructions: GEH-2728