

|      |           |     |     |
|------|-----------|-----|-----|
| SIZE | DWG NO.   | SHT | REV |
| C    | 65L924TK2 | 1   | 1   |

| REVISIONS |                   |      |          |
|-----------|-------------------|------|----------|
| REV       | DESCRIPTION       | DATE | APPROVED |
| 1         | UPDATE TO AUTOCAD |      | EJM      |

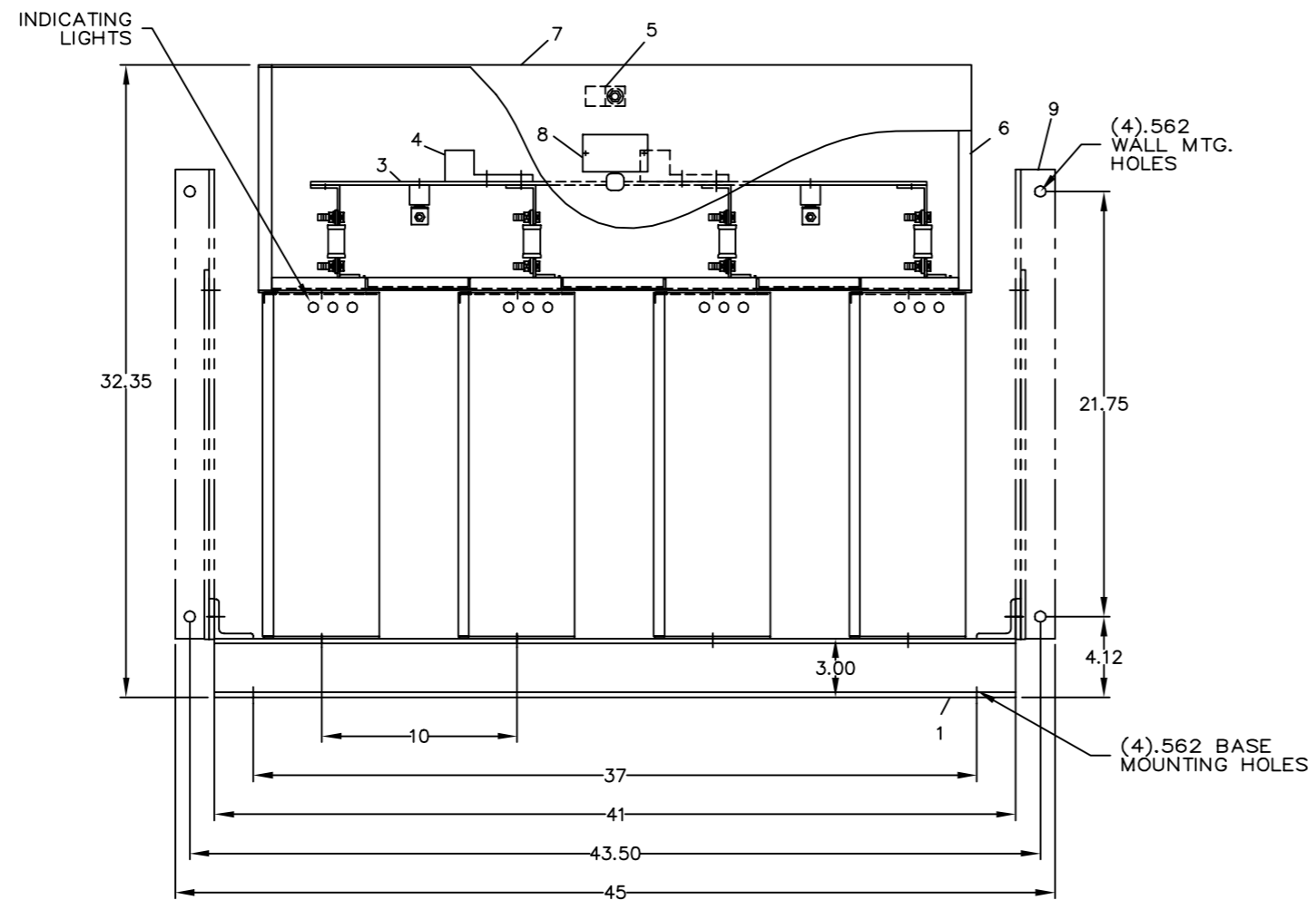

- NOMENCLATURE**
1. ALUMINUM BASE FRAME
  2. CAPACITOR UNIT
  3. COPPER BUS BARS
  4. LINE TERMINAL - #4/0 TO 600 MCM
  5. GROUND TERMINAL - #6AWG TO 250 MCM
  6. BUS ENCLOSURE
  7. ACCESS COVER
  8. RATING NAMEPLATE
  9. OPTIONAL FIELD ASSEMBLED WALL MTG. FRAME

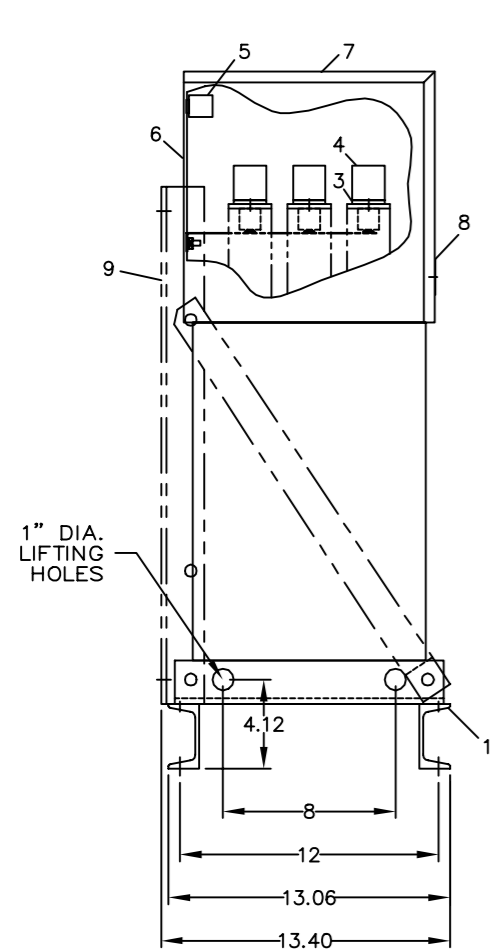
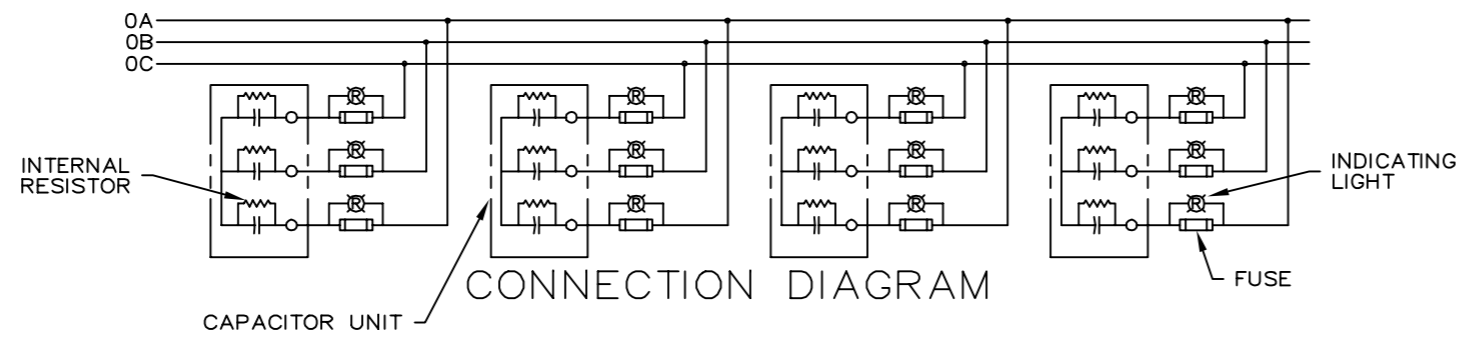

|                |  |         |          |   |             |      |  |
|----------------|--|---------|----------|---|-------------|------|--|
| SIGNATURES     |  | DATE    |          | <b>INDUSTRIAL SYSTEMS</b><br><b>FORT EDWARD, N.Y., U.S.A.</b> |             |      |  |
| DRAWN E.McGINN |  | 9/29/93 |          |   |             |      |  |
| CHECKED        |  |         |          | <b>OUTLINE</b><br><b>65L924TK2</b>                            |             |      |  |
| ENGR           |  |         |          |   |             |      |  |
| ISSUED         |  | 9/30/93 |          |   |             |      |  |
| CAD SYS. NO.   |  | AUTOCAD |          | FIRST MADE FOR:   |             | 4-13 |  |
|                |  | SIZE    | FSCM NO. | DWG NO.   | REV         |      |  |
|                |  | C       |          | 65L924TK2   | 1           |      |  |
|                |  | SCALE   | SHEET 1  |   | CONT ON SHT |      |  |

CAT 65L924TK2 SERNO  
 KVAR 190 60Hz 3ph  
 VOLT 600 DIAG 186C3233GA  
 CONN Y-CONN

Read instructions: GEH-2728