



MULTILIN

GER-3178

GE Power Management

Local Back-up Protection for an Electric Power System



LOCAL BACK UP PROTECTION FOR AN ELECTRIC POWER SYSTEM

J. BERDY

TABLE OF CONTENTS

Transmission Line Back-Up Protection	1
Single-Bus Arrangement	1
Double Bus - Double Breaker Arrangement	2
Breaker-and-One-Half Bus Arrangement	3
Ring-Bus Arrangement	4
Back-Up Protection of High-Voltage Buses	4
Single-Bus Arrangement	4
Sectionalized Single-Bus Arrangement	5
Double-Bus Arrangements	5
Relay Backup	5
Breaker Backup	5
Back-Up Protection of Generators	6
Relay Backup	6
Breaker Backup	6
Back-Up Protection of Transformers	7
Relay Backup	7
Breaker Backup	7

The basic purpose of this article is to present the current ideas and practices used in providing backup protection on modern electric utility systems. Consideration is given to the back-up protection of transmission lines, high voltage busses, generating stations, and transformers.

Each year as line and system loadings increase and more operating companies superimpose higher voltage transmission systems on existing facilities, the need for high speed fault clearing, particularly in the face of a relay or circuit breaker failure, is accentuated. In such instances, the answer is invariable local back-up protection for circuit breaker failure and, in many cases, local back-up protection for relay failure. In some instances, the need for positive, high speed clearing of all faults is so acute that two separate sets of primary relaying have been employed, with one set arbitrarily designated as back-up.

The general philosophy of the protective schemes described in this paper has been used by many large and small utilities over the last five years to meet their protective system requirements.

TRANSMISSION LINE BACK-UP PROTECTION

The primary objective of back-up protection is to open all sources of generation to an uncleared fault on the system. To accomplish this objective, an adequate back-up protective system must meet the following functional requirements:

1. It must recognize the existence of all faults which occur within its prescribed zone of protection.
2. It must detect the failure of the primary protection to clear any fault as planned.
3. In clearing the fault from the system, it must
 - a. Initiate the tripping of the minimum number of circuit breakers.

- b. Operate fast enough (consistent with coordination requirements) to maintain system stability, prevent excessive equipment damage, and maintain a prescribed degree of service continuity.

In the discussion which follows, a local back-up system is presented which meets all of the above requirements and which closely approaches ideal back-up relaying. This proposed scheme is designed so that no single failure in either the a-c circuits, the relays or in the d-c control and trip circuits (except station battery failure) can nullify all protection.

In essence, the proposed local back-up system provides two separate back-up functions: it provides relay backup with an entirely separate group of relays from that used for front-line protection, and it provides breaker backup with the necessary time delay and auxiliary relay components. The basic plan of the proposed scheme is the same for any breaker position, regardless of the bus arrangement being used. Only the details of the breaker back-up protection are changed for different bus arrangements.

Single-Bus Arrangement

The basic plan of the proposed scheme can be illustrated most simply by showing its application to a line connected to a single-bus arrangement. Figure 1 shows a functional diagram of the scheme in just such an application. The front-line protection shown in this diagram can be distance-carrier relaying, pilot-wire relaying, phase comparison-carrier relaying, some form of microwave relaying, distance relays or simple overcurrent relays. Relay backup may be identical to the primary protection, or it may be one of the other types. Ideally, the primary protection and the relay backup are supplied from separate current and potential sources.

For faults on the protected line, both the primary and the back-up relays will operate to trip the line breaker. Relay backup does not require any added time delay, and hence may be just as fast as the frontline relays. When either of these relays operates to trip the line breaker, it also energizes a timer to start the breaker back-up function. If the breaker on the line fails to clear, these relays will remain picked up, permitting the time to time out and trip the remaining breakers off the bus.

It should be noted that the breaker back-up function requires that the relay contacts remain closed for the duration of the fault, whether the fault is in the first or second zone, so that the breaker back-up timer is allowed to time out when required. Hence, if the primary or back-up relays are distance relays, the second-zone trip contact of the distance-relay timer must be maintained.

The relay designated as "S" is an overcurrent relay which performs the following functions: it prevents inadvertent operation of breaker backup either by test personnel, or when a line breaker is tripped manually. The protective system for each line has an "S" relay connected as shown in Figure 1, and a contact from each "S" relay would be in parallel with the "S" contact in the output of bus timer.

The coverage provided by this scheme is as follows. If the primary relays (or current supply, etc.) fail, the backup relays will operate to clear the fault with no intentional time delay (relay backup). Likewise if the relay backup is inoperative, the primary relays continue to provide their primary relaying function. If the failure is beyond the relays (trip coil, trip mechanism, etc.) both sets of relays will operate the breaker back-up timer, which isolates the fault by tripping all necessary breakers in the minimum possible time.

In addition to the above coverage, this scheme is designed to that no single failure in the d-c control circuits (except station battery failure) can nullify all protection. Auxiliary relays are used where necessary to separate the d-c circuits and all d-c control and trip circuits are fused separately. It is assumed that only a common battery is available and that a separate battery cannot be justified.

Double Bus - Double Breaker Arrangement

Figure 2 shows a functional diagram of the proposed scheme for lines connected to a double bus-double breaker arrangement. It should be noted that the basic plan remains the same, except for the addition of an extra timer and two selector relays.

The operation of the primary protection and the relay backup are the same as for the single bus arrangement. They operate to trip breakers #1 and #2 for faults on line A, and they energize the breaker back-up function. The breaker back-up function consists of a timer for each bus and two selector relays for each line. The selector relays are used to indicate which line breaker has failed to clear so that only the necessary breakers are tripped to clear the fault. Without the selector relays, both buses would be cleared for a failure of one of the line breakers.

The operation of these selector relays and the breaker back-up function can be illustrated by a simple example. For instance, if breaker #1 fails to clear for a fault on line A, the line relays will remain picked up and the timer circuits will be energized. The timer for Bus X will not start, however, since the timer coil is in series with a contact of selector relay S_2 (relay S_2 will be de-energized since breaker #2 has opened). On the other hand, the timer for bus Y will start to time out since selector relay S_1 is still picked up. After a short time delay this timer will trip all breakers on bus Y.

The selector relays can generally be high dropout overcurrent relays. The setting of these relays is not critical since their primary function is to drop out rapidly when current no longer flows in their associated breakers. However, if the selector relays are set so that they can be picked up by load current, it is important that a relay be chosen which is capable of such operation.

In the above scheme, one timer could be used to perform the breaker back-up function if automatic reclosing of breakers is not used or if automatic reclosing is prevented until there was some indication that both breakers have opened to clear the fault. If automatic reclosing is permitted without such indication, there is danger of tripping both buses in case one of the line breakers fails to clear.

The following example will illustrate this point. When one timer is used, the only change in the circuit of Figure 2 would be that the selector relay contacts S_1 and S_2 would be in parallel coming out of the one timer. For this case, assume breaker #1 has failed to open. The line relays would remain picked up and would start the timer. After a short time delay, the timer would operate through the contacts of S_1 to initiate the tripping of the breakers on bus Y. However, if breaker #2 recloses just as the timer operates, the S_2 contacts would close (since fault current is still flowing) and the breakers on bus X would also be tripped. As mentioned previously, to prevent such an occurrence, some means would have to be used to prevent reclosing until there was some indication that both breakers had opened. This could be performed electrically by means of contacts on the selector relays, or by circuit breaker "b" switches. This would either delay a normal reclosing shot or would complicate the control circuits.

The use of two timers separates the control circuits for the two buses eliminating any

possibility of a false trip, and also provides a "cleaner" solution to the problem.

Breaker-and-One-Half Bus Arrangement

The functional diagram of the proposed scheme for this bus arrangement is shown in Figure 3. As for the double bus-double breaker case, the basic plan is the same, and the only change is in the details of the breaker back-up function.

In this case, the following components are required to provide the breaker back-up function:

1. Two Selector relays per line
2. A timer for each bus
3. A timer for each breaker adjacent to the bus (breakers #1 and #3 in Figure 3).

As explained in the preceding section, the selector relays are used to indicate the failure of a breaker to open. The bus timers are required to clear the buses when either breakers #1 or #3 fail to clear. The timers on breakers #1 or #3 are required to clear these breakers in backup for breaker #2.

The operation of this scheme is as follows: If for a fault on line A, breaker #1 fails to open, the bus Y timer is energized and it will clear the bus after a short time delay. The timer for breaker #3 will not be energized since the selector relay S_2 drops out when breaker #2 clears.

Now assume for a fault line A, that breaker #2 fails to clear. In this case, breaker #3 timer will be energized and after a short time delay breaker #3 will be tripped. To completely clear the fault, the remote end of line B will have to be tripped. If ordinary distance relays are being used, the remote end of line B will be tripped in second-or third-zone time. If some form of pilot

relaying is used, the breaker #3 timer can be used to stop the blocking signal on line B, thus permitting the remote end to trip at a second-zone time level. This unblocking feature has decided advantages since it permits backup relaying at one lower time level.

For faults on line B, and for a failure of either breakers #2 or #3, the same sequence of events would occur to trip either breaker #1 or bus X.

In this scheme, one timer per line could be used instead of the number listed above, if automatic reclosing is not permitted or if automatic reclosing is prevented until there was some indication that both breakers had opened to clear the fault. The reason for this is the same as for the double bus-double breaker case.

Ring-Bus Arrangement

Figure 4 illustrates the back-up scheme proposed for lines connected to a ring-bus arrangement. As can be seen in this diagram, the primary and relay back-up functions operate in the same manner as those for the other bus arrangements.

The breaker back-up function requires two selector relays per line, and a timer for each breaker. These components are used to provide breaker back-up protection in the following manner. In the ringbus arrangement of Figure 4, a fault on line A would normally be cleared by breakers #1 and #2. If one of these breakers fails to clear, then one of the adjacent breakers and the remote end of one of the adjacent lines must be tripped to clear the fault. The proposed scheme accomplishes this required backup operations as shown in Figure 4. For faults on line A, the primary and back-up relays initiate the tripping of breakers #1 and #2 and at the same time energize timers which are on adjacent breakers #3 and #4. If breakers #1 and #2 trip correctly, the timers will drop out.

However, if for example, breaker #2 fails to clear, the timer on breaker #3 will continue to time out and will trip breaker #3 through the S_2 contacts. The remote terminal of line B would be tripped by one the methods described in the preceding section. Similarly, breaker #4 and the remote end of line D will trip in case breaker #1 fails to clear.

Breaker #3 also backs up breaker #4 and breaker #4 backs up breaker #3. Hence, breaker #3 timer will be energized by the primary and back-up relays of line D and breaker #4 timer will be energized by the relay on line B. The timers on breakers #1 and #2 also serve dual functions. Breaker #1 timer backs up breakers #2 and #4 for faults on lines B and C, respectively, while breaker #2 timer backs up breakers #1 and #3 for faults on lines D and C, respectively.

BACK-UP PROTECTION OF HIGH-VOLTAGE BUSES

Single-Bus Arrangement

Bus back-up protection is inherently provided by the primary relaying at the remote ends of the lines connected to the bus. The second zones of remote distance relays will operate in second-zone time to clear all lines from a faulted bus.

All other equipment connected to the bus, such as generators and transformers are provided with backup relays which are set to function in the event of an uncleared bus fault.

For sustained phase faults on the bus, local generation is cleared from the bus by a single-zone distance relay having two time steps, as shown in Figure 5. In the event the bus-differential relay fails, breaker #1 is tripped by the relay Z in time T_A . If breaker #1 fails, the turbine-generator unit is shut down by Z in time T_B . This back-up relay on the generator terminal

provides backup protection for everything but the station battery and is a good example of nearly complete duplication of all elements.

For uncleared bus ground faults, the local generation is cleared by a ground back-up relay in the main transformer neutral as shown in Figure 5. Two-step time operation can be obtained by means of one instantaneous overcurrent relay and a timer or by means of two time-delay overcurrent relays.

Large power transformers are cleared from a faulted bus by time overcurrent or distance-type relays if there is a source of generation on the unfaulted side of the transformer.

In the foregoing discussion, the remote line relays and the relays on the local equipment provide both relay and breaker backup for the single-bus arrangement. In most instances, this form of back-up protection will be entirely adequate even though the back-up clearing times will be rather long.

In those instances where high-speed back-up relaying is necessary to maintain system stability, consideration has been given to the use of duplicate bus-differential relays. In this scheme, each differential relay operates from a separate set of current transformers and both relays are set to operate without time delay for bus faults.

Sectionalized Single-Bus Arrangement

As for the single bus, back-up protection for the sectionalized single bus is provided by remote line relays and by relays on the equipment connected to the bus. In addition to this protection, some form of local back-up relaying is required if the maximum number of unfaulted bus sections is to be kept in service in the event of a bus-tie breaker failure.

Bus-tie breaker backup can be provided with selector relays and a timer as shown in Figure 6. In this scheme, if one of the bus-tie breakers fails to clear for a fault on bus B, the differential relay will remain picked up and the timer will trip the necessary breakers to isolate the fault. Selectivity for the scheme is provided by the selector relays S_3 and S_6 . These relays indicate which bus-tie breaker has failed and channel the timer tripping function to the proper breakers.

Double-Bus Arrangements

Relay Backup. Relay back-up protection for double-bus arrangements, using either double-breaker or breaker-and-a-half schemes, is usually provided by remote relays on lines and by back-up relays on equipment connected to the buses. This relay backup will disconnect all lines and equipments from the buses in the event of a bus-differential relay failure. This type of relay backup may be slow in operation and will invariably cause the shutdown of a large system area. If it is necessary to have high-speed back-up operation to maintain stability or if it is desirable to limit the extent of a system outage, duplicate bus-differential relays can; be used as described earlier.

Breaker Backup. Breaker back-up protection for double-bus arrangements requires the use of both local and remote back-up relaying if the the unfaulted bus is to remain in service in the event of a breaker failure. An illustration of this form of back-up protection for a double-breaker scheme is shown in Figure 7. If it is assumed breaker #1 fails to clear for fault on bus Y, both breaker #2 and the remote breaker on line A must open to clear the fault. With breaker #2 open, bus X will remain in service. To accomplish this purpose, instantaneous overcurrent selector relays, marked S_1 , S_3 , and S_5 are used to detect a breaker failure on bus Y and selector relays S_2 , S_4 , and S_6 detect the failure of a breaker on bus X. Again, if it is assumed that breaker #1 fails to

operate for a fault on bus Y, selector relay S1 remains picked up and breaker #2 is tripped after a short time delay as shown in Figure 7. The time delay is required to permit reset of selector relays S₃ and S₅.

The remote end of line A would be opened by second or third zones of distance relays or by “unblocking” if some form of pilot-relaying is used. Remote back-up relays on all other circuits connected to bus X are selective with the local back-up relays and bus X remains in service.

Breaker back-up protection for breaker-and-one-half schemes, shown in Figure 8, would be similar to that for the double-breaker schemes. In this case, the failure of any bus breaker requires the tripping of the center breaker and the remote end of one of the lines.

BACK UP PROTECTION OF GENERATORS

Most of the new installations of generators, both steam and hydro, are of the unit-generator and transformer type. The primary protection consists of high-speed generator-differential and transformer differential relaying. A diagram showing the unit scheme protection is shown in Figure 9.

Relay Backup

Back-up protection against relay failure is not normally applied to large generators. Their operation is closely supervised and the primary protection provides enough overlap and duplication of the various protective functions to make separate back-up relaying generally considered as unnecessary.

The main transformer-differential relay includes the generator in its zone of protection and gives relay backup protection to the generator-differential relay. Additional relay backup is

obtained on large steam-turbine generators from the ground relay. The single-turn coil, bar-winding construction of these units practically assures that phase-to-phase faults will also involve ground.

With high-resistance grounding, the ground relay is the only protection against internal generator ground faults. If the ground relay fails, the fault will not be cleared unless it spreads and becomes serious enough to operate the differential relays.

Breaker Backup

The generator back-up protection thus far described provides relay backup only. If breaker backup is desired, then the primary protective relays may be connected to start a timer which would trip all breakers on the bus after a short interval of time. It is important to note that short-circuit current for a fault in the generator zone will continue to flow even after the main generator and field breakers are open and hence the primary relays may remain in the picked-up position for a considerable period of time. Therefore, after a normal operation of the primary relays and breakers, some means must be used to prevent the breaker back-up timer from clearing the bus. Since the short-circuit current for a fault in the generator zone may be small (e.g., a partial transformer fault), it is impractical to determine electrically whether the main generator breaker has opened. Consequently, it is necessary to resort to the use of a breaker “a” switch, connected to permit back-up timer operation only while the breaker is closed. A selector relay energized from current transformers in the generator breaker can be used to detect the more severe faults in the generator zone, but such a relay cannot replace the “a” switch.

Relays on the generator terminals, such as impedance and voltage-restrained overcurrent

types, are often thought of as “generator back-up” relays. This is not strictly correct since these relays are for back-up protection against uncleared bus faults, as has been described. They would more correctly be called “system-fault” or “bus” back-up relays. However, these relays do provide some measure of backup protection for both the generator and main transformer.

BACK UP PROTECTION OF TRANSFORMERS

Relay Backup

The primary protection for large transformers, almost without exception, is high-speed differential relaying. Relay back-up protection, when provided, usually consists of a fault-pressure relay, a tank-to-ground relay, time overcurrent relays or distance relays. See Figure 10(a). The time overcurrent relay is provided for system fault back-up protection but gives some

relay back-up protection for moderate to severe internal transformer faults.

Breaker Backup

To provide breaker backup, a primary relay plus timer scheme, similar to that shown in Figure 10(b), could be used. Again, it is noted that selector relays are not adequate but may be used in addition to breaker “a” switches for selection of the proper back-up breakers to trip.

If the transformer of Figure 10(a) is connected in a line without a line-side breaker, the remote breaker would be tripped by transferred-trip signal initiated by the transformer-differential relays. If the remote breaker failed to trip for any reason, the transformer fault would not be cleared. However, at least one installation is planned in which a second transferred-trip channel will be used to trip the remote bus if the remote line breaker does not operate.

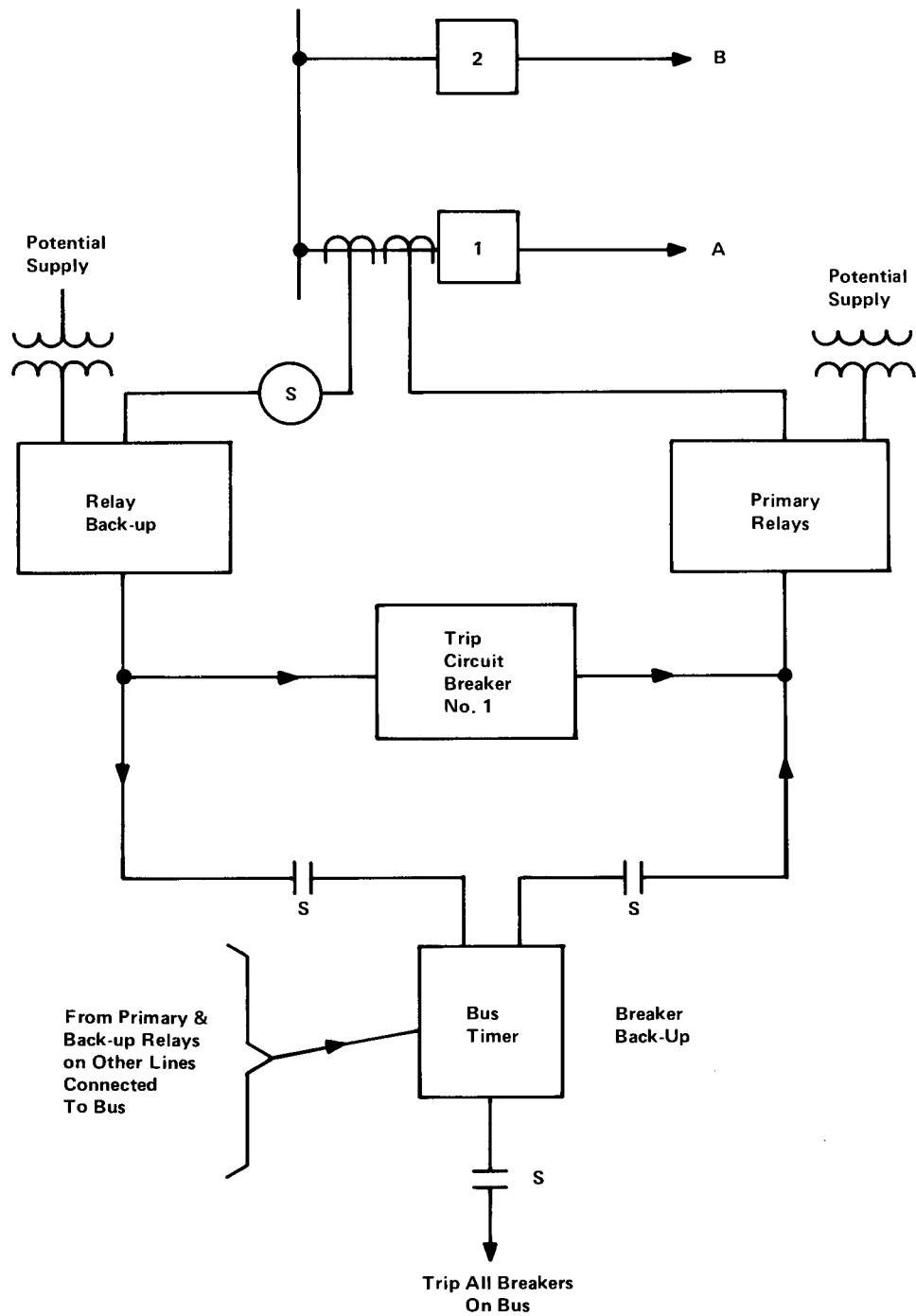

Fig. 1. Proposed back-up scheme for a line connected to a single bus

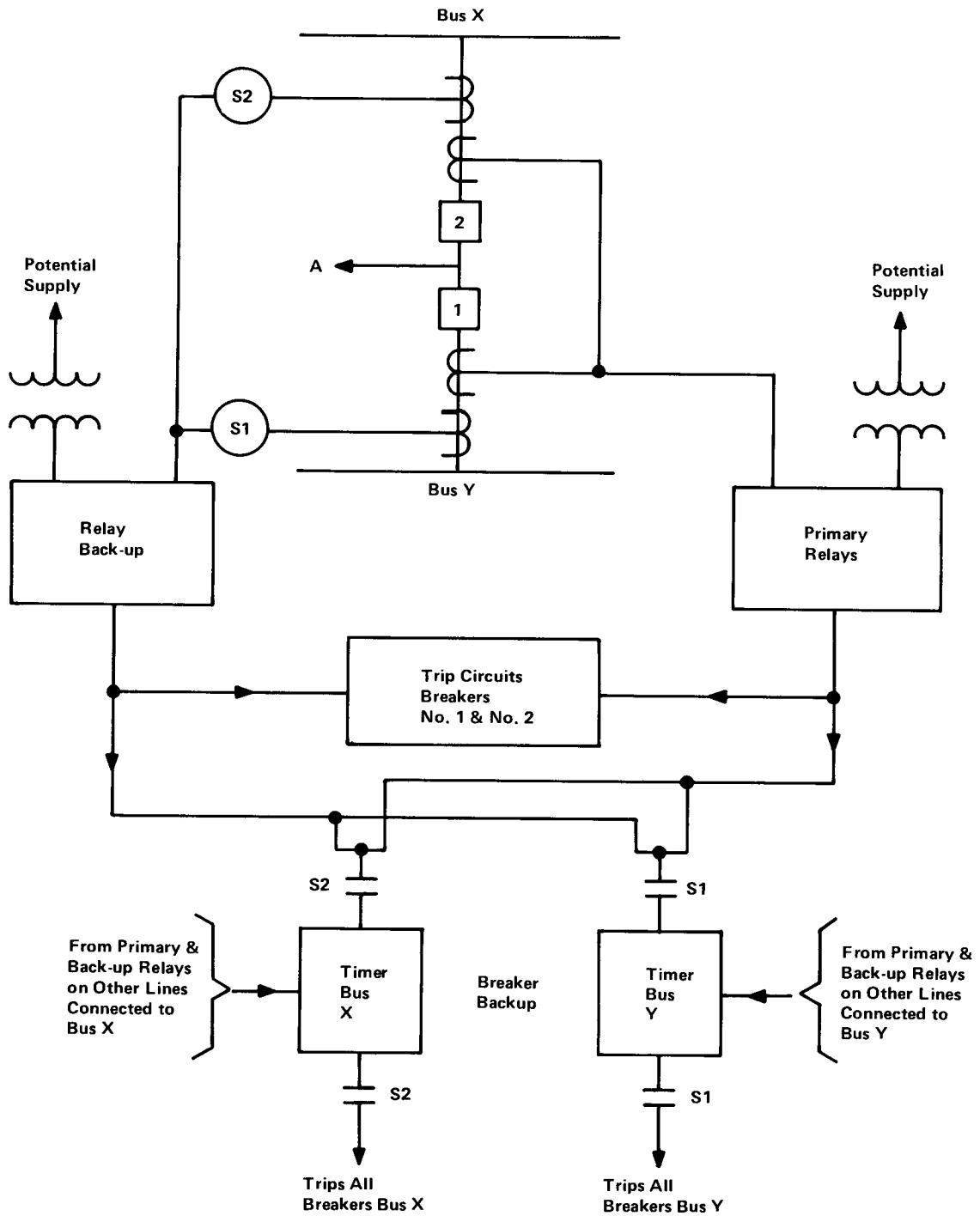

Fig. 2. Proposed back-up scheme for a line connected to a double bus-double breaker arrangement

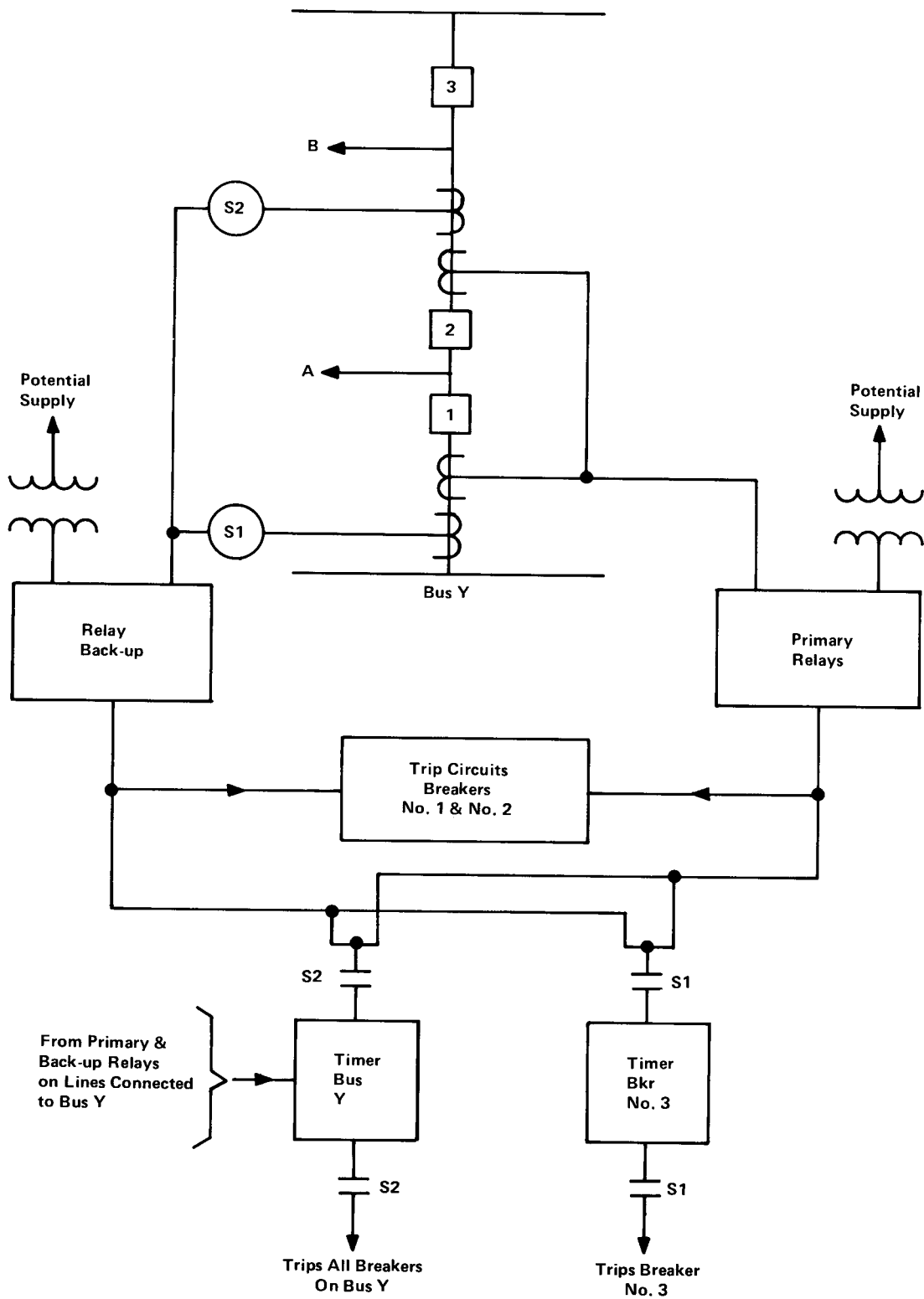

Fig. 3. Proposed back-up scheme for a line connected to a breaker-and-a-half arrangement

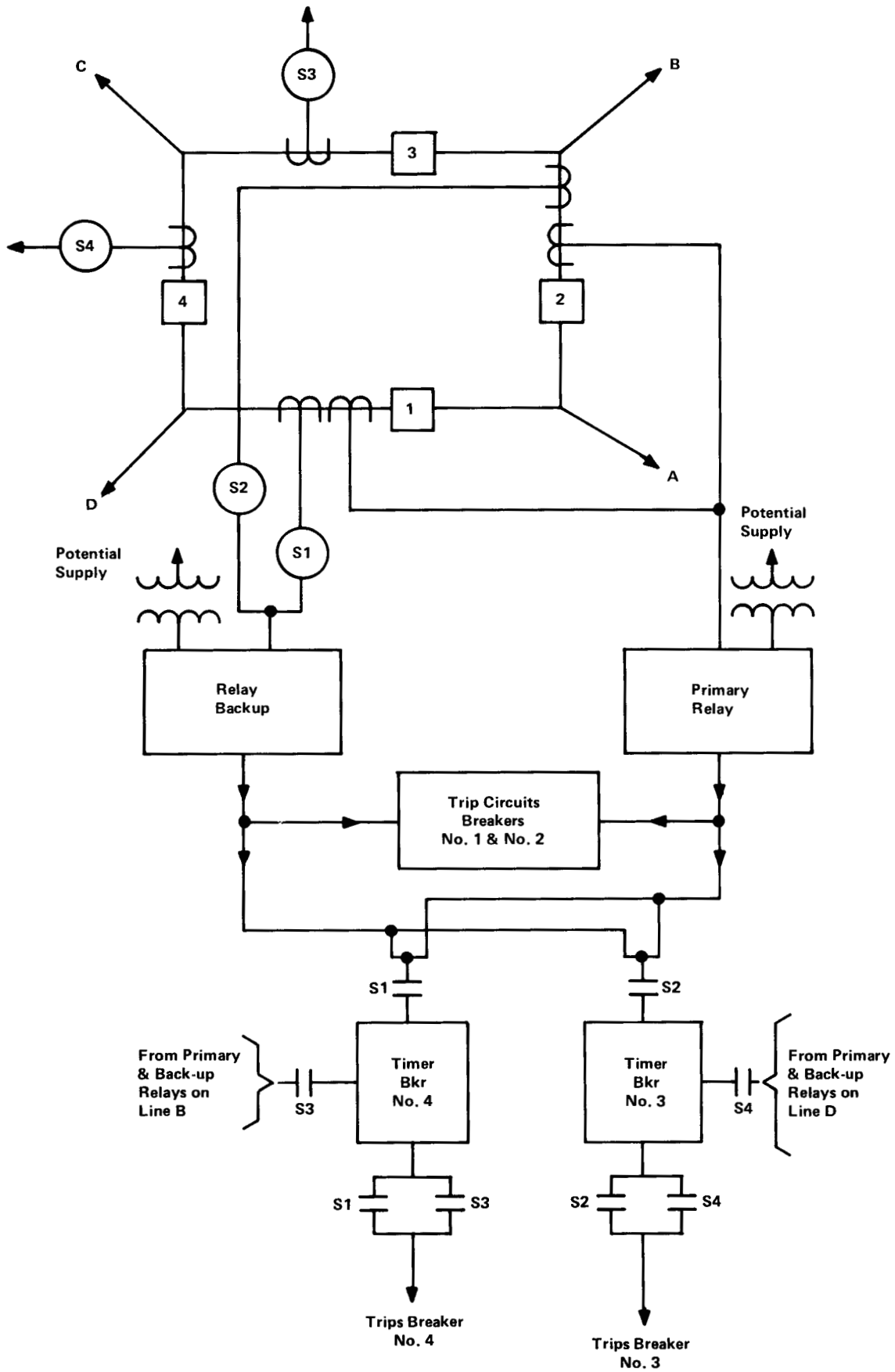

Fig. 4. Proposed back-up scheme for a line connected to a ring bus

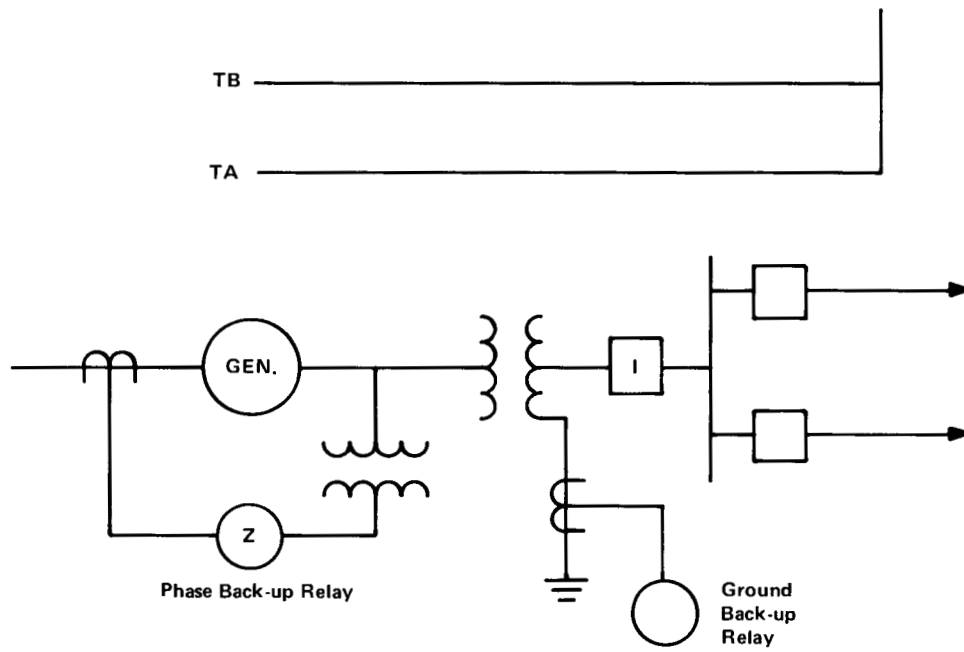

Fig. 5. Phase and ground back-up relays which clear local generation for sustained bus faults

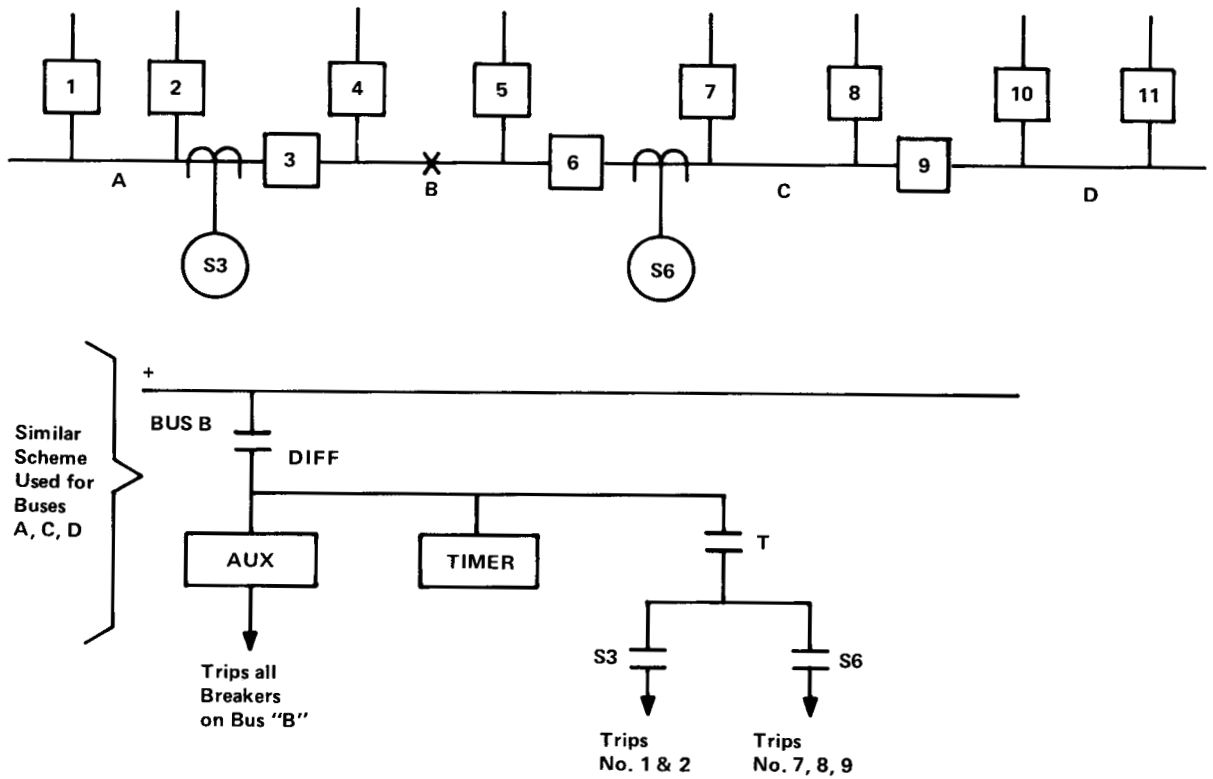

Fig. 6. Bus-tie breaker backup, sectionalized single bus

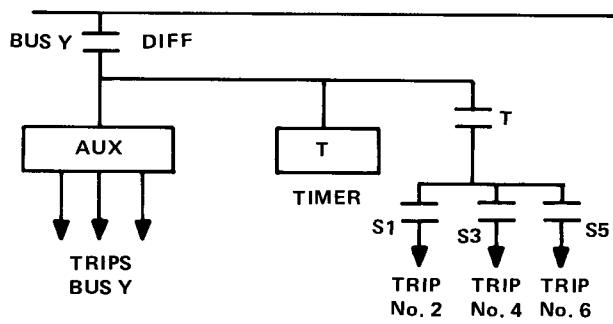
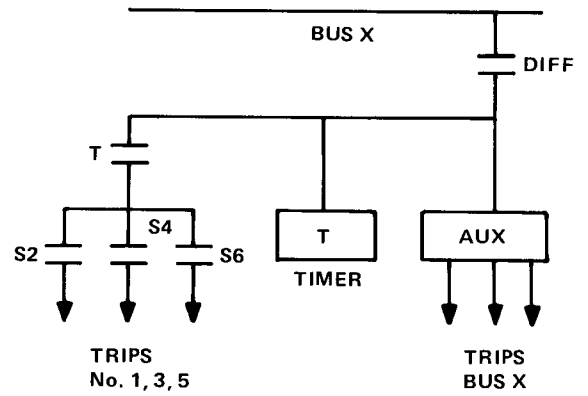
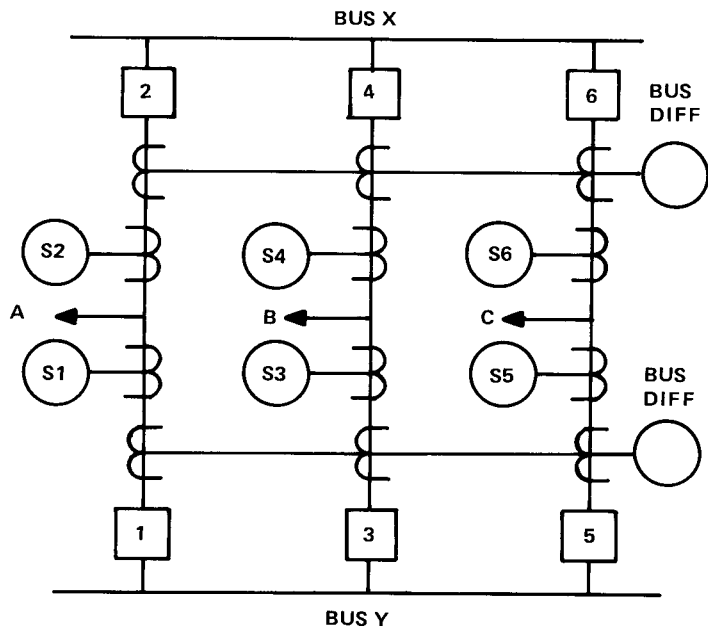

Fig. 7. Breaker backup for double bus-double breaker arrangement

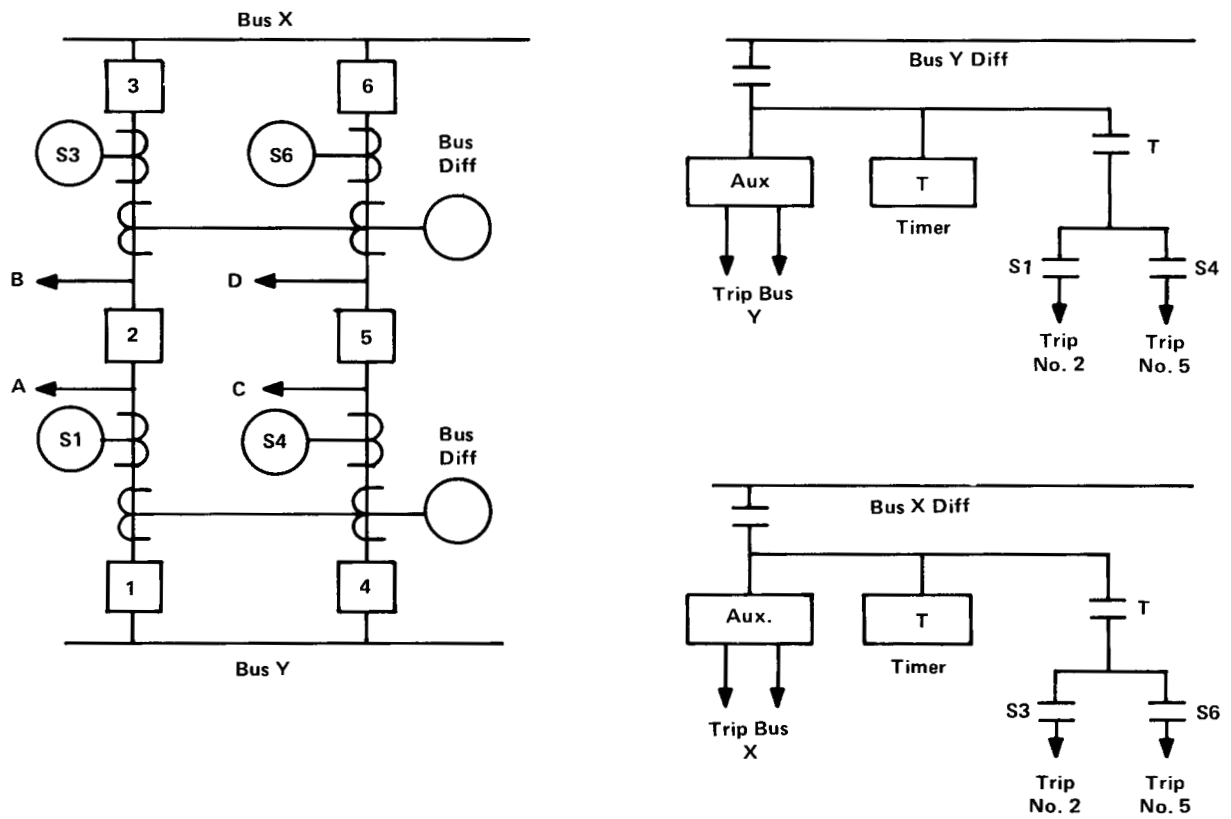

Fig. 8. Breaker backup for breaker-and-a-half schemes

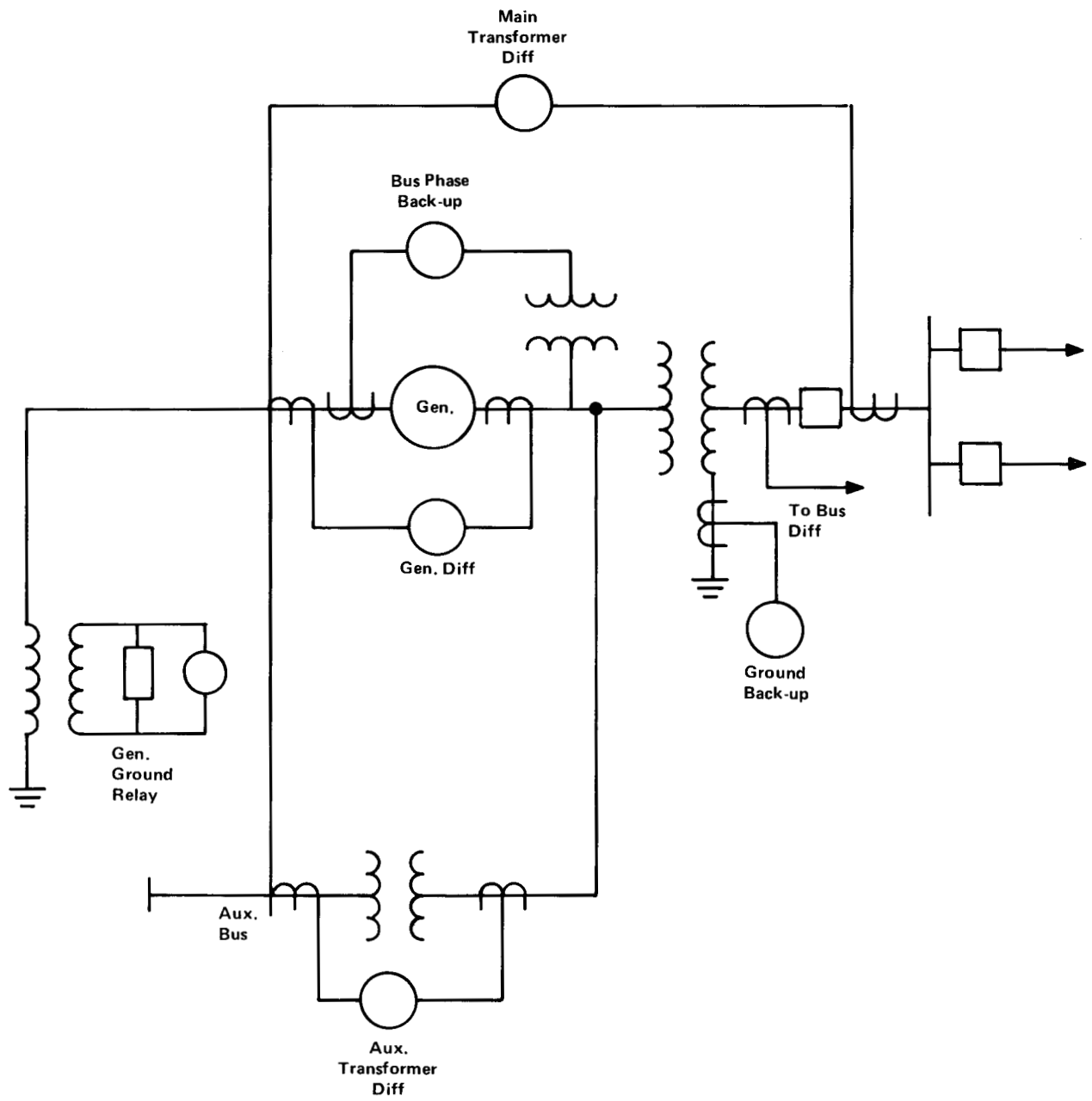

Fig. 9. Unit Generator-Transformer Scheme

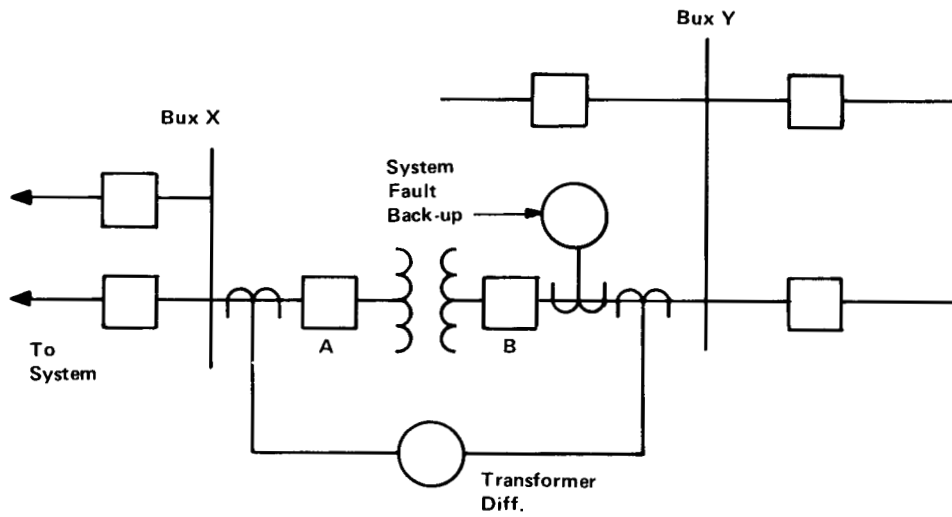

Fig. 10a

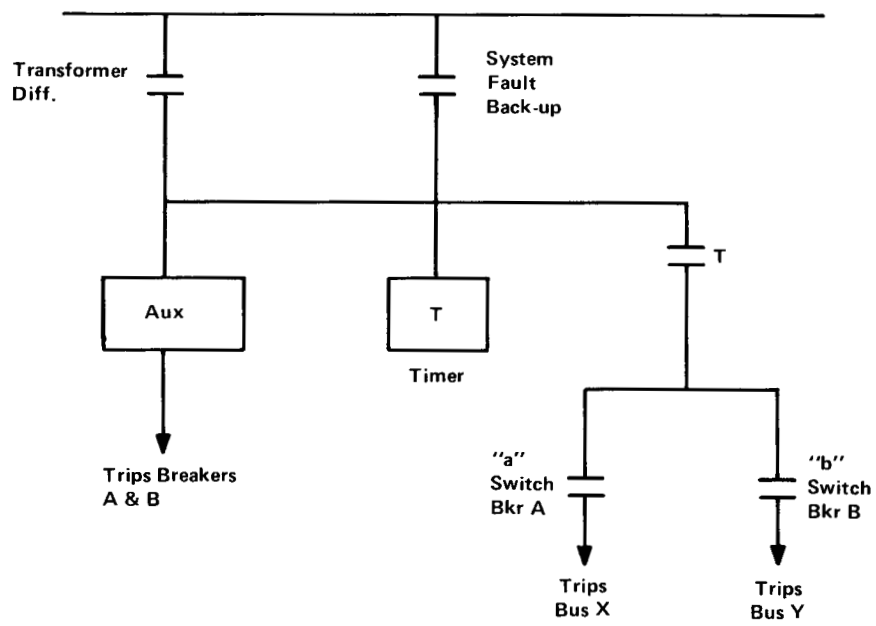

Fig. 10b

Fig. 10. Backup protection for transformers



GE Power Management

215 Anderson Avenue
Markham, Ontario
Canada L6E 1B3
Tel: (905) 294-6222
Fax: (905) 201-2098
www.GEindustrial.com/pm