



**REPLACEMENT REDUCTION GEAR AND MOTOR
UNIT FOR TYPES AK 50/75/100, AKT 50 AND
AKU 50 POWER CIRCUIT BREAKERS.**

Contents

Section I. Introduction

Section II. Quick Close Operation

- A. Breaker Disassembly
- B. Breaker Reassembly
- C. Control Wire Modifications

Section III. Standard Close Operation

- A. Breaker Disassembly
- B. Breaker Reassembly
- C. Control Wire Modifications

Section IV. Renewal Parts

These instructions do not purport to cover all details or variations in equipment nor to provide for every possible contingency to be met in connection with installation, operation or maintenance. Should further information be desired or should particular problems arise which are not covered sufficiently for the purchaser's purposes, the matter should be referred to the General Electric Company.

I. INTRODUCTION

These installation instructions cover the replacement of the Gear Reduction and Motor unit used on the type AK 50/75/100 Power Circuit Breakers. The catalog numbers of these units, which are now obsolete, are

177L362G2 for Standard Close Operation
177L362G3 for Quick Close Operation

Table 1 lists the kits available. The installer should verify that the correct kit was ordered and furnished.

The components provided are shown in Figs. 4 & 12. The right side support assembly shown is supplied in all kits, but is used only with type AK/AKT/AKU 50 breakers in AKD 5 equipment.

Users are reminded that replacement of the Gear Reduction and Motor unit provides an excellent opportunity to perform normal maintenance on the breaker proper, particularly while the front and back frames are separated. Such procedures are covered in the Maintenance manual, GEK 7303, which is included in each kit.

| Replacement Kit Cat. No. 343L761 (Group No.) | | | | | | | | | |
|--|---------|-----------------------|-------|--------|-----------|--------------------------|-------|--------|-----------|
| | | Quick Close Operation | | | | Standard Close Operation | | | |
| | | Type of Equipment | | | | Type of Equipment | | | |
| Hertz | Voltage | AKD & Stationary | AKD 5 | | | AKD & Stationary | AKD 5 | | |
| | | | AK 50 | AKT 50 | AK 75/100 | | AK 50 | AKT 50 | AK 75/100 |
| DC | 48 | G28 | G10 | G19 | G1 | G37 | G49 | G61 | G37 |
| | 125 | G29 | G11 | G20 | G2 | G38 | G50 | G62 | G38 |
| | 250 | G30 | G12 | G21 | G3 | G39 | G51 | G63 | G39 |
| 25 | 120 | G33 | G15 | G24 | G6 | G42 | G54 | G66 | G42 |
| | 208 | G36 | G18 | G27 | G9 | G48 | G60 | G72 | G48 |
| | 240 | G36 | G18 | G27 | G9 | G47 | G59 | G71 | G47 |
| 50 | 120 | G32 | G14 | G23 | G5 | G41 | G53 | G65 | G41 |
| | 208 | G35 | G17 | G26 | G8 | G46 | G58 | G70 | G46 |
| | 240 | G35 | G17 | G26 | G8 | G45 | G57 | G69 | G45 |
| 60 | 120 | G31 | G13 | G22 | G4 | G40 | G52 | G64 | G40 |
| | 208 | G34 | G16 | G25 | G7 | G44 | G56 | G68 | G44 |
| | 240 | G34 | G16 | G25 | G7 | G43 | G55 | G67 | G43 |

Table 1 — Replacement Motor Operator Kits

II. QUICK CLOSE OPERATION

A. Breaker Disassembly

The following components will be removed from the breaker’s front frame (refer to Figs. 2 & 3)

- Motor/Gear reducer assembly
- Quick close mechanism
- Motor cut-off switch unit
- Right side support assembly - For AK/AKT/AKU 50 breakers in AKD-5 equipment only

If the W relay is mounted on the motor cut off switch unit it must be relocated to the right side of the center channel.

WARNING: Before starting any work, disconnect the breaker from all power sources (primary and secondary) and place in clean work area.

1. Be sure breaker is open and discharged
2. Insert safety pin. Refer to maintenance manual GEK 7303, pg. 5.

3. Remove the arc chute retaining bar
4. Remove the arc quenchers, lifting them clear of the moveable arcing contacts. Remove the two inter-phase barriers.
5. Separate the breaker front frame from its back frame. Refer to GEK 7303, pg. 7. For Power Sensor equipped breakers refer to GEK 7303, pg. 35-39 for additional information. For SST programmer equipped breakers disconnect the Programmer/Phase Sensor harness connector, refer to Fig. 1.
6. Referring to the Elementary Quick Close wiring diagram, Fig. 1A, GEK 7303 and Fig. 2:
 - a. Remove and identify the wires from terminals 3 and 4 of the closing relay contacts (D switch).
 - b. Remove and identify the wires from the neutral and hot side of the closing relay coil (CC).

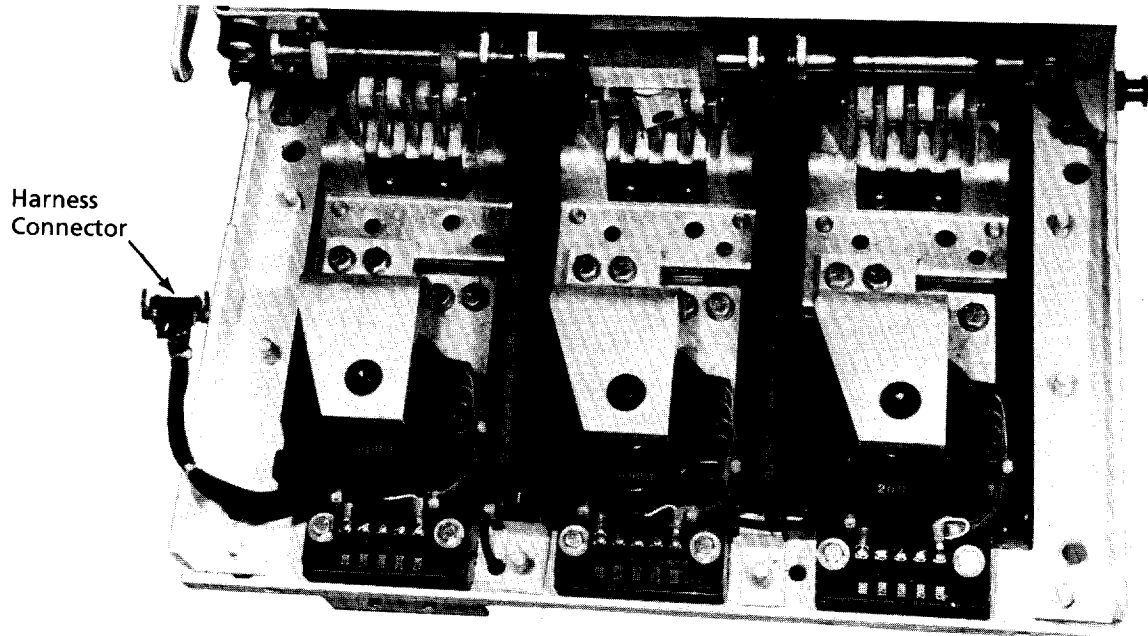

Fig. 1 — View of drawout breaker back frame showing the programmer/phase sensor harness connector.

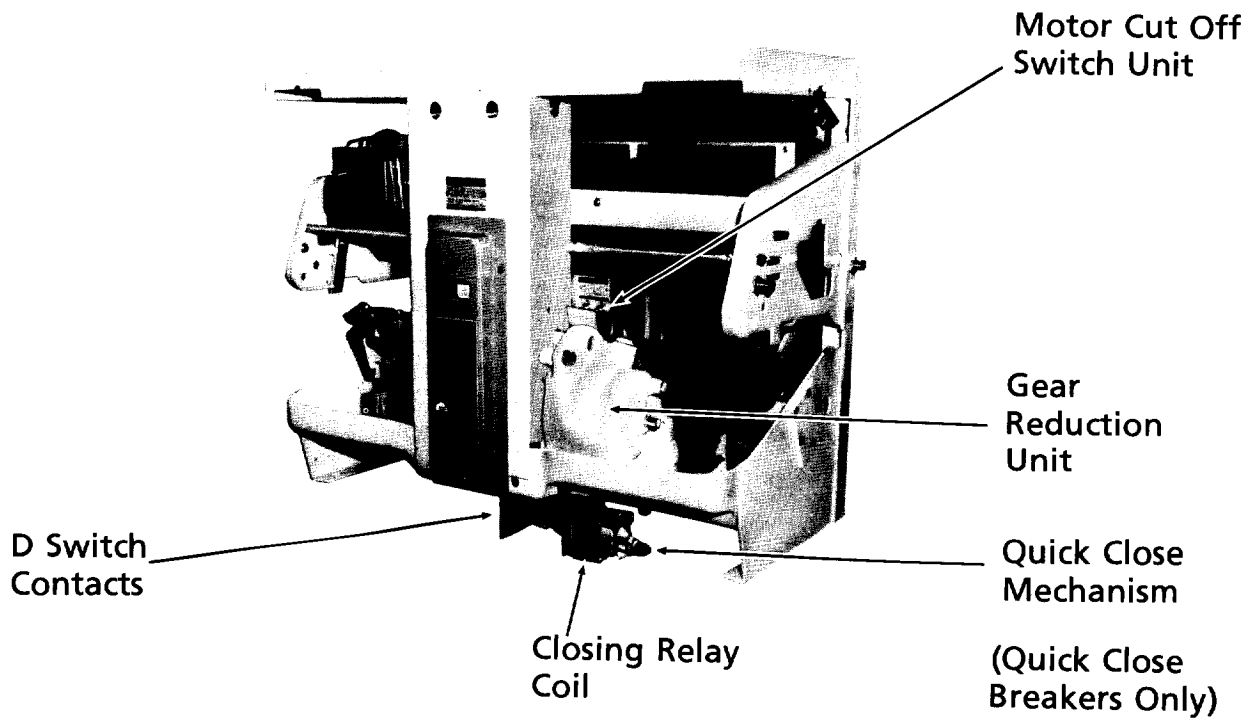

Fig. 2 — Typical components that will be replaced.

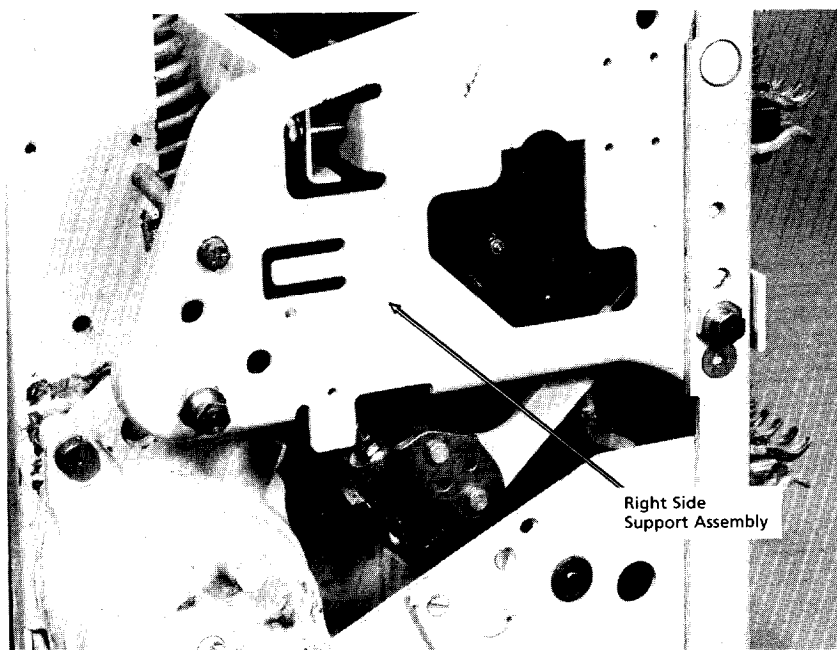

Fig. 3 — Right side support for AKD 5 equipment

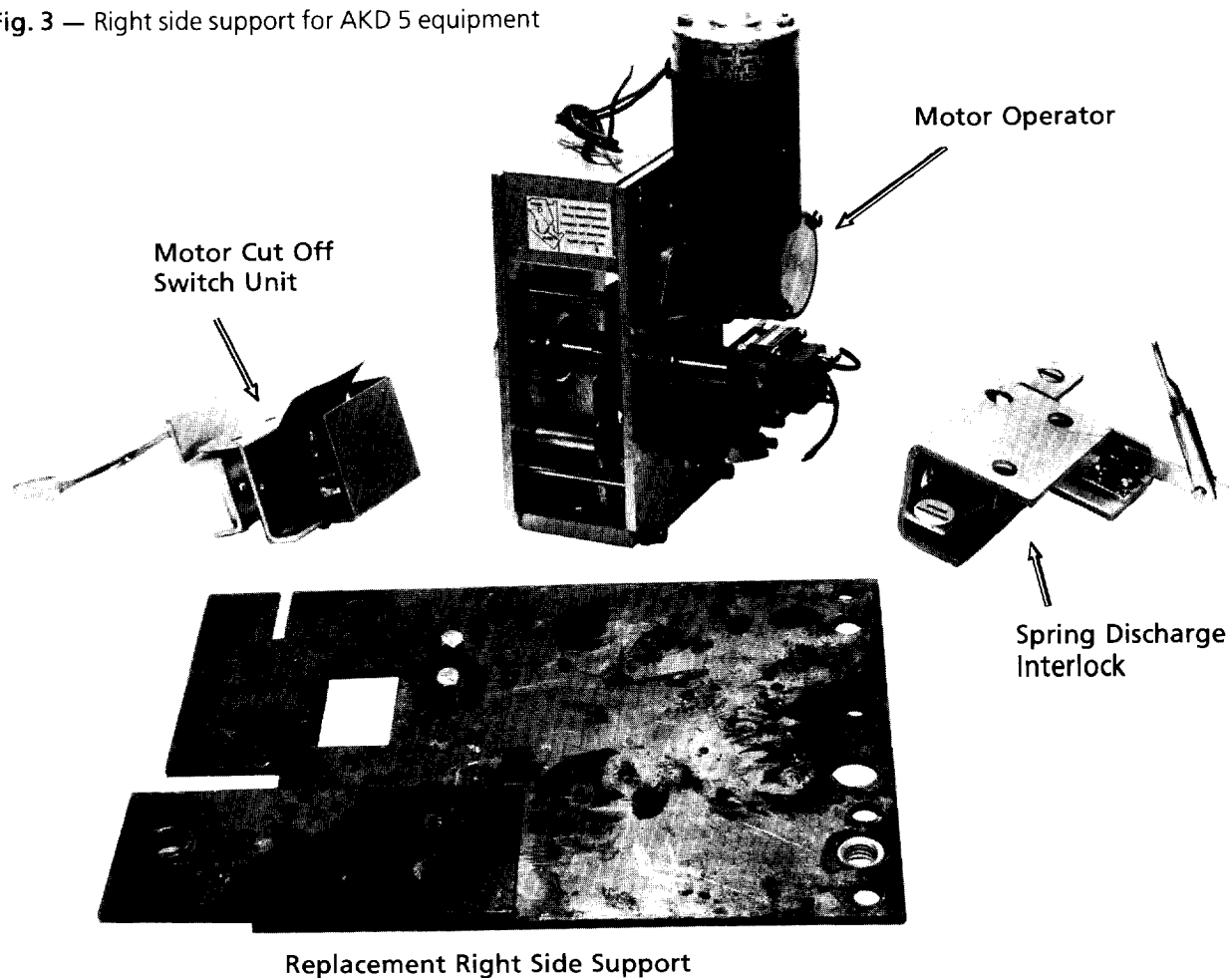

Fig. 4 — Kit contents for quick close breakers.

- c. Remove the motor lead from the G switch. The G switch is part of the motor cut-off switch and is mounted next to the center channel. This lead goes directly to the motor, therefore remove it from the wire harness.
Remove and identify the remaining wire to the G switch.
- d. Remove and identify the F switch wires. The F switch is the remaining part of the motor cut-off switch unit.
- e. Trace and remove the remaining motor lead from the wire harness. It should be one of the neutral side wires at the closing relay coil. If this wire does not end up at the closing relay coil, cut it at a convenient location and identify it.

As mentioned above, when removing any wire identify it using Brady markers or an equivalent type of identifying means. A chart similar to the one shown in Table 2 should also be used.

- 7. Remove any wire harness supports that are attached to the gear reduction unit or quick close mechanism.
- 8. Remove the two bolts at the bottom of the front frame which mount the quick close mechanism. Remove this mechanism and its associated assembly which is inside the center channel.
- 9. Remove the five bolts which mount the motor and gear reduction unit. Remove this unit from the frame.
- 10. Remove the motor cut-off switch unit from the side channel. Remove the nameplate from the cover of this switch unit. This nameplate must be installed on the cover of the replacement switch unit. NOTE: If the breaker being converted is an AK-3 type (Power Sensor equipped), the "W" relay is mounted to the switch unit. Carefully remove this relay from the switch unit. Do not disconnect any wires from the "W" relay. It will be relocated on the center channel.
- 11. **For AK/AKT/AKU 50 Breakers in AKD-5 Equipment Only** Remove the right side support assembly. Refer to Fig 3. This assembly will be replaced by the assembly provided in this replacement kit.

Table 2 — Suggested Wire Identification Chart

| Identification No. | Component Description |
|--------------------|------------------------------------|
| | Terminal #3 Closing Relay Contacts |
| | Terminal #4 Closing Relay Contacts |
| | Closing Relay Coil |
| | Closing Relay Coil - Neutral Side |
| | Motor Lead to G Switch |
| | Motor Lead - Neutral Side |
| | G Switch Terminal |
| | F Switch Terminal - Upper |
| | F Switch Terminal - Lower |

¹Refer to the elementary quick close wiring diagram, Fig. 1A GEK 7303.

²Some terminals have more than one wire connected to them. Identify these wires with the same number.

B. Breaker Reassembly

The components shown in Fig. 4 are supplied in the replacement motor operator kit. A brief description of each component is given below.

Motor cut off switch unit - same as existing unit, except for the paddle. The paddle design coordinates the switch unit's operation with the new motor operator.

Motor operator assembly - replaces the existing motor and gear reducer.

Spring discharge interlock mechanism - requires the closing spring to be discharged each time the breaker is removed from or installed into its equipment. It also discharges the closing spring after charging with the maintenance handle.

Right side support assembly - for type AK/AKT/AKU 50 breakers in AKD-5 equipment only.

- 1. If the W relay (anti-pump) is mounted on the motor cut off switch unit, it must be relocated to the right side of the center channel.
 - a. Using the pattern given in Fig. 5 add the two 8-32 tapped holes as shown. Carefully clean up all metal filings.
 - b. Referring to Fig. 5, mount the W relay using the hardware provided.

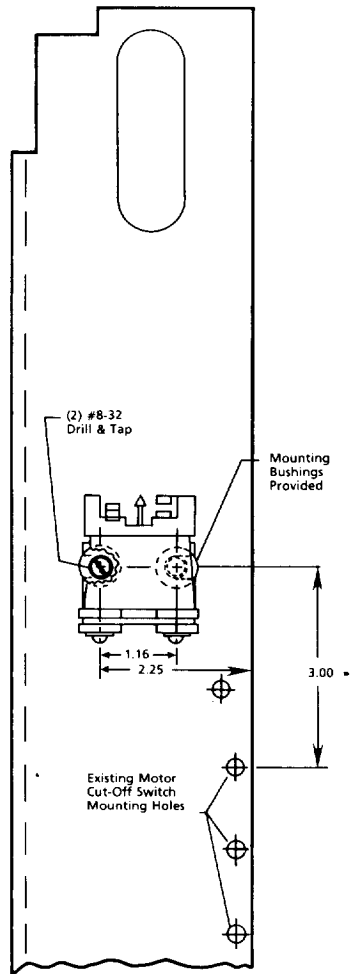

Fig. 5 — Relocated 'W' (anti-pump) relay

2. Install the new motor cut-off switch unit using the old unit's mounting holes in the center channel. New hardware is provided. The spacer is part of the lower hole hardware. Refer to Fig. 6. Install the original control voltage nameplate to the cover of the new cut off switch unit.
3. Install the motor operator assembly and spring discharge interlock mechanism to the front frame. Refer to Fig. 7. The necessary hardware and spacers are provided. The motor operator crank roller must engage with the guide on the cam shaft paddle, refer to Fig. 8. Also refer to Fig. 10 and 13 in GEK 7303. The cam shaft must engage with the motor operator as it did with the old gear reducer unit, refer to Fig. 9. NOTE: There may be interference between the motor operator frame and the opening spring bracket on some breaker models. If this interference exists, remove the necessary material from the bracket.

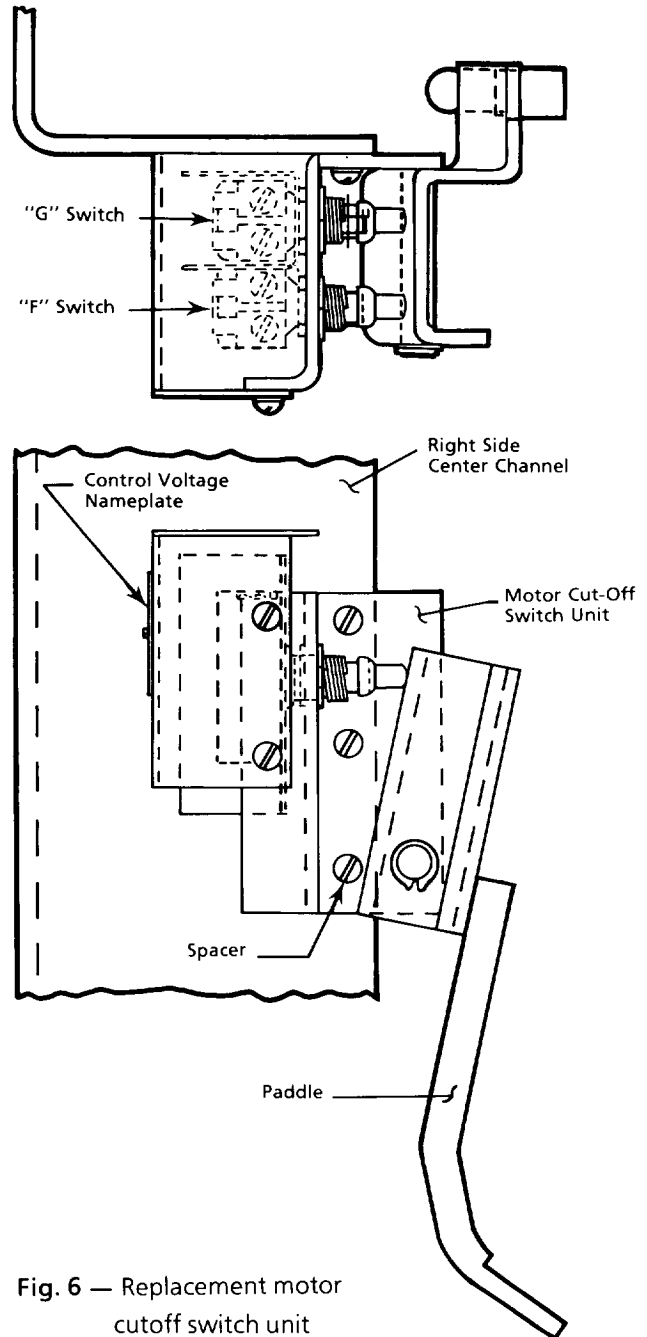

Fig. 6 — Replacement motor cutoff switch unit

4. The drive link which is part of the spring discharge mechanism must be connected to the closing solenoid pivot arm which is on the motor operator. The retaining ring is provided. Refer to Fig. 7. Turning the drive link will vary its length. This provides the adjustment necessary to make the pivot arm connection. It also provides the height adjustment for the interlock pin.

5. Once the replacement components have been installed on the front frame refer to Section 11C below for instructions on connecting these components to the existing control wiring.
6. When all the above conversion steps are completed, the breaker frames can be reassembled. If the breaker being converted is on AK/AKT/AKU 50 used in AKD 5 equipment, replace the right side support with the support assembly provided. Refer to Fig. 10.

C. Control Circuit Modifications

1. No additional components were added to the control circuit. The wiring terminals of the replacement components may be in different locations than the existing terminals. This requires modification to existing wire leads. Wire terminals, splicing terminals and wire are provided to make these modifications.
2. Refer to Table 2 or your own wire identification chart and the elementary quick close wiring diagram, Fig. 1A, GEK 7303 when you wire the replacement components to the existing control harness.
3. The new closing solenoid has terminals on it which are electrically isolated from its coil winding. These terminals are used as connection points for the closing solenoid coil leads, the control relay leads and the one motor lead.

NOTE: Either motor lead or closing solenoid lead can be used as the neutral wire.

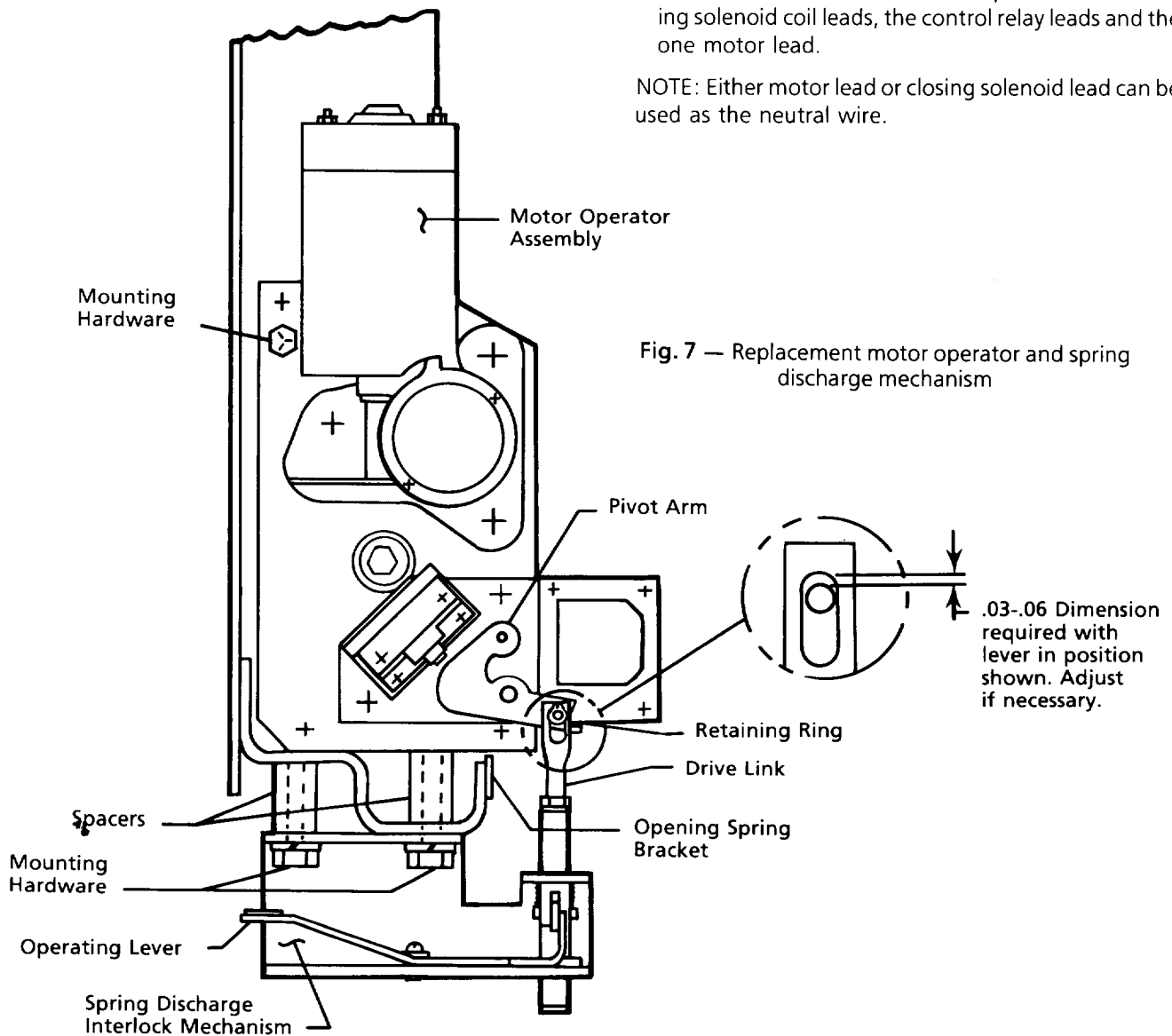

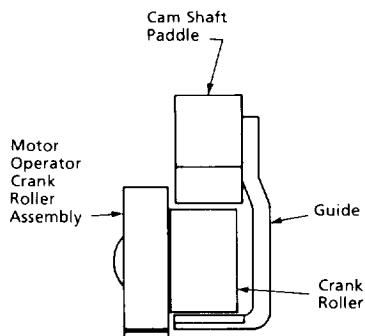

Fig. 8 — Engagement of the motor operator crank roller with the cam shaft paddle.

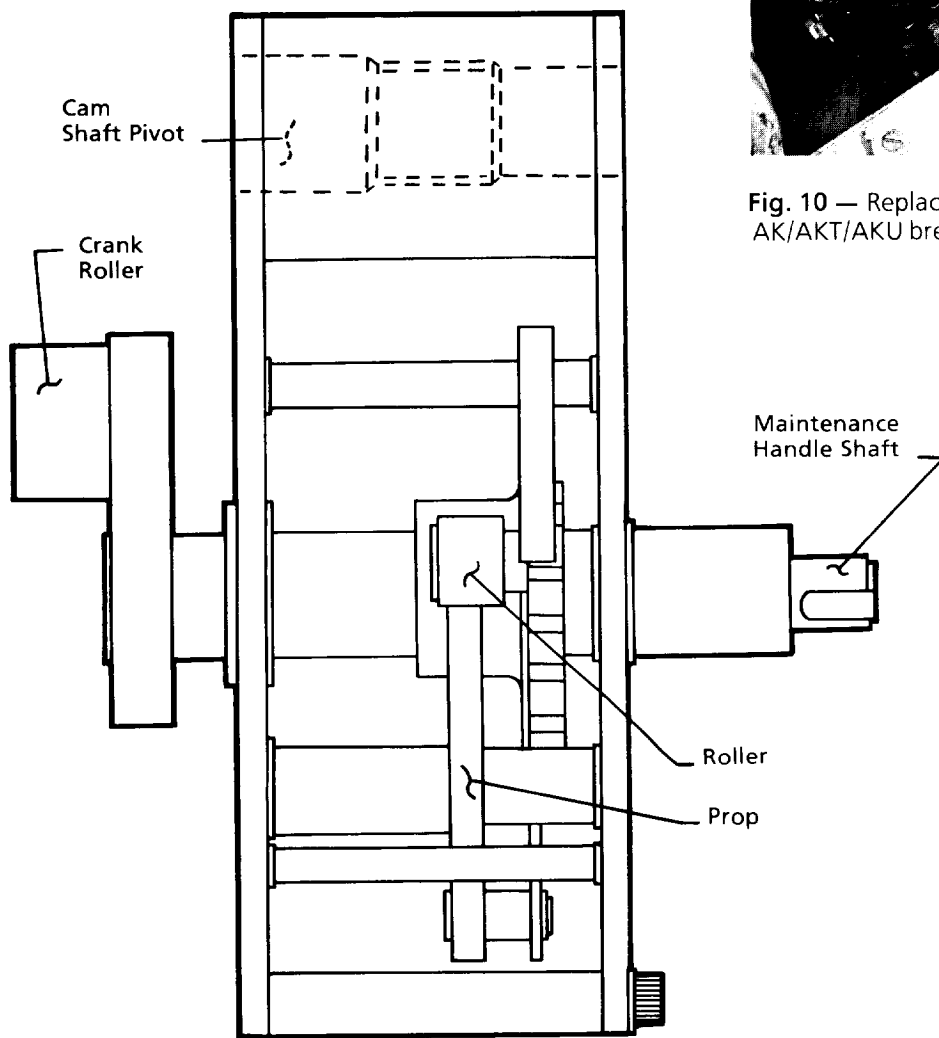

Fig. 9 — Motor operator unit

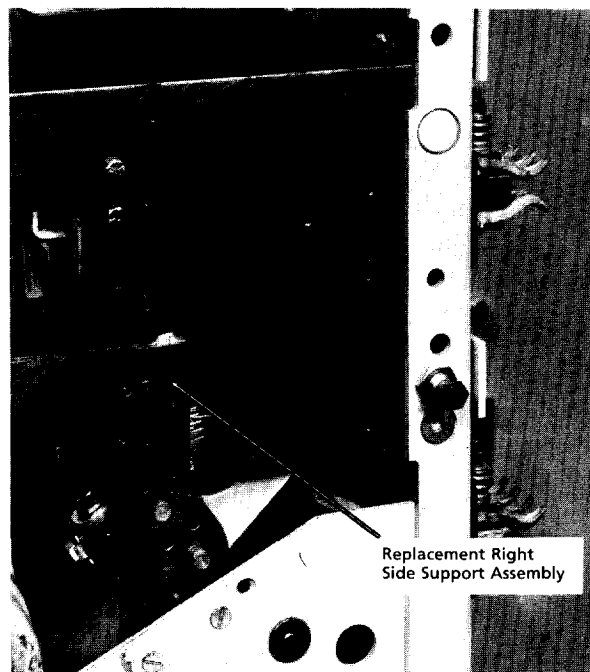

Fig. 10 — Replacement side support installed on AK/AKT/AKU breakers - AKD 5 equipment only.

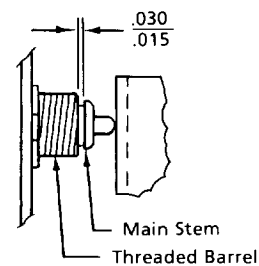

Fig. 11 — Motor cutoff switch adjustment

7. Remove the safety pin by placing your maintenance handle on the shaft which extends from the motor operator unit and charge the closing spring until the motor operator roller engages with the motor operator prop, refer to Fig. 9. Remove the safety pin. Close the breaker by depressing the spring discharge lever, which removes the prop from the roller. Open the contacts by tripping the breaker.
8. Operate the breaker using the maintenance handle and spring discharge mechanism a few times. Verify that the breaker is operating properly.
9. Before applying control voltage to your breaker, verify that the motor cut off switches are properly adjusted. Charge the closing spring as described in Step 7 (roller resting on prop). Adjust the motor cut off switches so that they are depressed to the point where the main stem of each switch is located .015" minimum to .031" maximum from the threaded barrel, see Fig. 11.
10. When the control voltage is applied to your breaker, the motor operator will be energized and charge the closing spring. The G switch (see Fig. 6) of the motor cut off switch unit will stop the motor operator just before the roller engages with the prop. The breaker may be closed manually by depressing the spring discharge lever or electrically by energizing the closing solenoid.

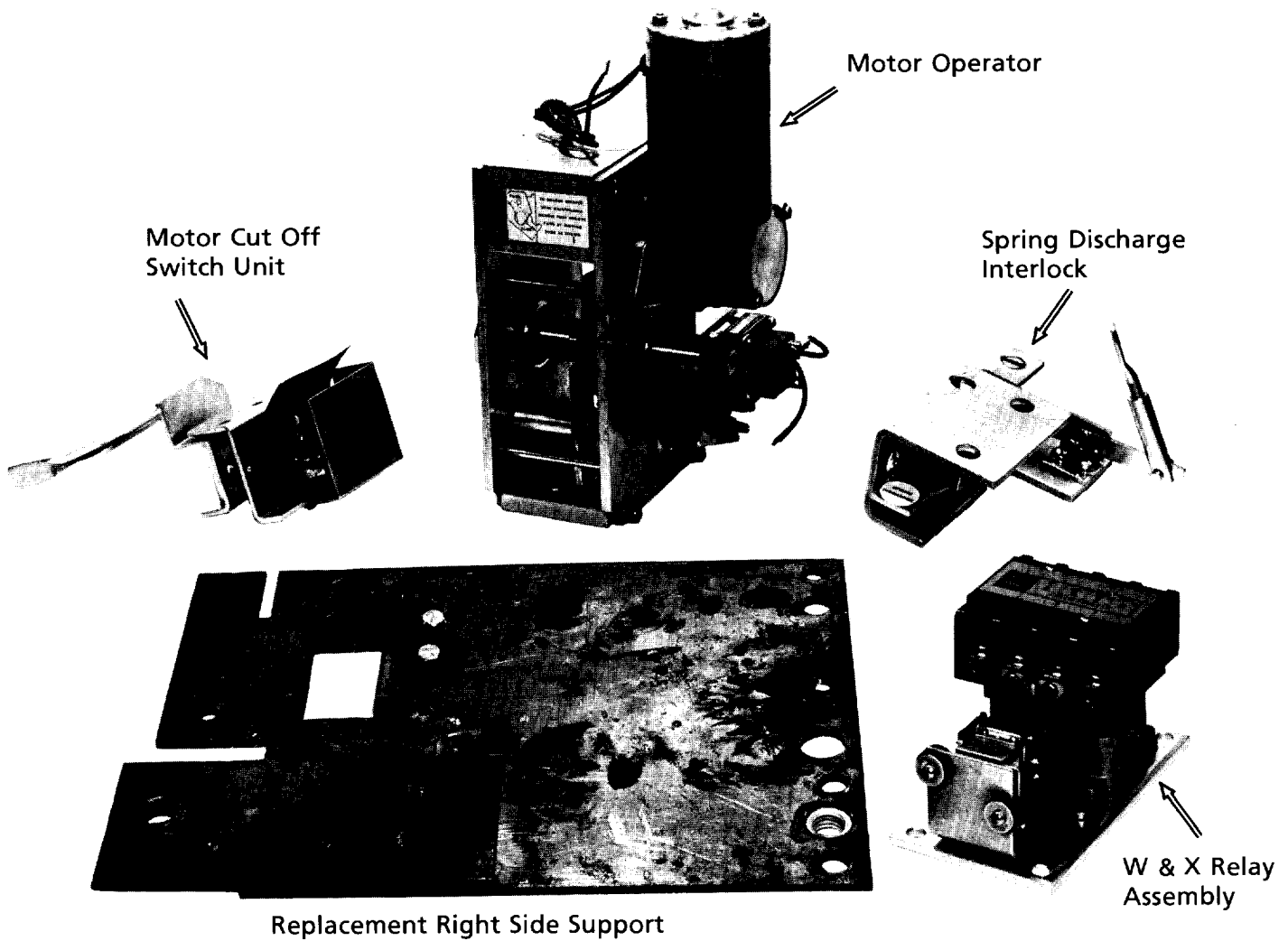

Fig. 12 — Kit contents for standard close breakers.

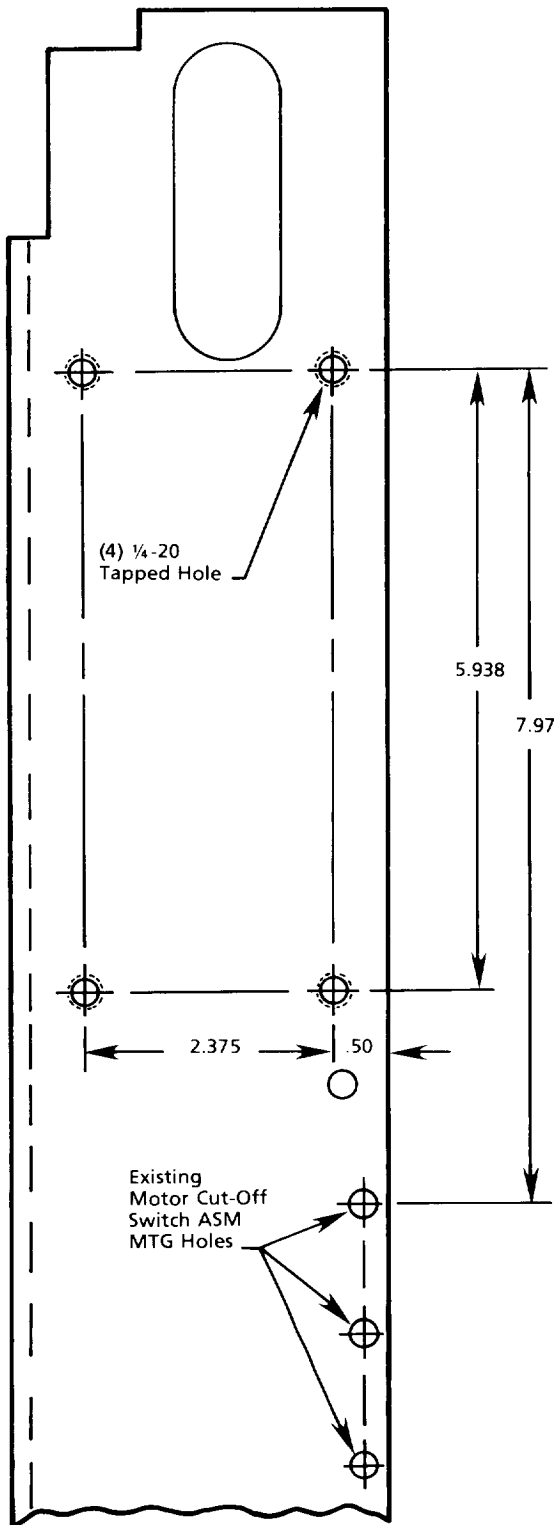

Fig. 13 — Mounting pattern for X & W relay assembly



Fig. 14 — W & X relay assembly installed on standard close breaker.

III. STANDARD CLOSE OPERATION

A. Breaker Disassembly

The following components will be removed from the breaker's front frame (refer to Figs. 2 & 3).

- Motor/Gear reducer assembly
- Motor cut-off switch unit
- Right side support assembly - For AK/AKT/AKU 50 breakers in AKD-5 equipment only

WARNING: Before starting any work, disconnect the breaker from all power sources (primary and secondary) and place in clean work area.

1. Be sure breaker is OPEN and DISCHARGED.
2. Insert safety pin. Refer to maintenance manual GEK 7303, pg. 5.
3. Remove the arc chute retaining bar.

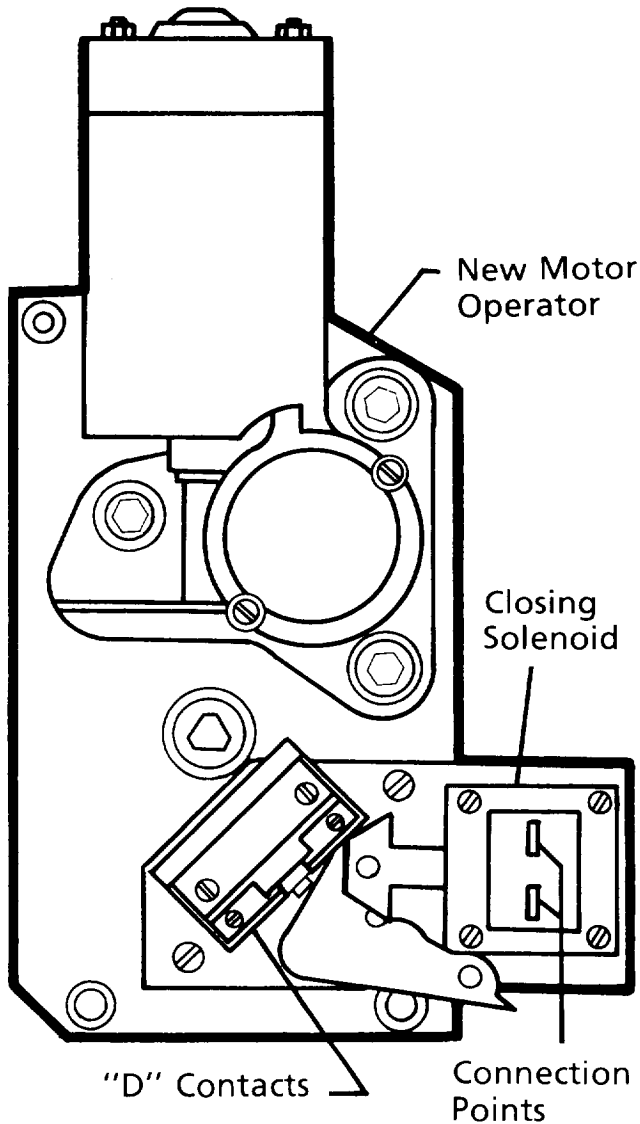

Fig. 16 — Location of the closing solenoid and closing solenoid contacts

4. Remove the arc chutes, lifting them clear of the moveable arcing contacts. Remove the two inter-phase barriers.
5. Separate the breaker front frame from its back frame. Refer to GEK 7303, Pg. 7. For Power Sensor equipped breakers refer to GEK 7303, pg. 35-39 for additional information. For SST programmer equipped breakers disconnect the Programmer/Phase Sensor harness connector, refer to Fig. 1.
6. Disconnect the motor leads from the control wiring.
7. Disconnect the wires to the motor cut off switches.
8. Remove any wire harness supports that are attached to the gear reduction unit.
9. Remove the five bolts which mount the motor and gear reduction unit. Remove this unit from the frame.

10. Remove the motor cut off switch unit from the side channel. Remove the nameplate from the unit's cover. This nameplate must be installed on the cover of the replacement cut off switch unit.
11. **For AK/AKT/AKU 50 Breakers in AKD-5 Equipment Only** Remove the right side support assembly. Refer to Fig. 3. This assembly will be replaced by the assembly provided in this replacement kit.

B. Breaker Assembly

The components shown in Fig. 12 are supplied in the replacement motor operator kit. A brief description of each component is given below.

'W' and 'X' relay assembly - required to convert the existing control circuitry for use with the new motor operator.

Motor cut off switch unit - same as existing unit, except for the paddle. The paddle is shaped for the new motor operator.

Motor operator assembly - replaces the existing motor and gear reducer.

Spring discharge mechanism - used to discharge the closing spring when the closing spring is charged with the maintenance handle. This mechanism can also be used as an interlock which requires the closing spring to be discharged each time the breaker is removed or installed into its equipment. For enclosed stationary breaker's, a clearance hole may be required for the mechanism pin.

Right side support assembly - for type AK/AKT/AKU 50 breakers in AKD-5 equipment only.

1. The W and X relay assembly must be installed to the right side of the center channel. Using the pattern given in Figure 13 add the 4, ¼-20 tapped holes as shown. Carefully clean up all metal filings.
2. Referring to Figure 14 mount the W and X relay assembly using the hardware provided.
3. Install the new motor cut-off switch unit using the old unit's mounting holes in the center channel. New hardware is provided. The spacer is part of the lower hole hardware. Install the original control voltage nameplate to the cover of the new cut off switch unit.
4. Install the motor operator and spring discharge interlock mechanism to the front frame. Refer to Figure 7. The necessary hardware and spacers are provided. The motor operator crank roller must engage with the guide on the cam shaft paddle, as shown in Figure 8. The cam shaft must engage with the motor operator as it did with the old gear reducer unit, refer to Fig. 9.

NOTE: There may be interference between the motor operator frame and opening spring bracket on some breaker models. If this interference exists, remove the necessary material from the bracket.

5. The drive link which is part of the spring discharge mechanism must be connected to the closing solenoid pivot arm which is on the motor operator. Refer to Figure 7. Turning the drive link will vary its length. This provides the necessary adjustment to activate the pivot arm.
6. Once the replacement components have been installed on the front frame, refer to Section III C below for instructions on modifying the control wiring.
7. When all the above conversion steps are completed the breaker frames can be reassembled. If the breaker being converted is on AK/AKT/AKU 50 used in AKD-5 equipment, replace the right side support with the support assembly provided. Refer to Fig. 10.
8. Remove the safety pin by placing your maintenance handle on the shaft which extends from the motor operator unit and charge the closing spring until the motor operator roller engages with the motor operator prop, refer to Figure 9. Remove the safety pin. Close the breaker by depressing the spring discharge lever, which removes the prop from the roller. Open the contacts by tripping the breaker.
9. Operate the breaker using the maintenance handle and spring discharge mechanism a few times. Verify that the breaker is operating properly.
10. Before applying control voltage to your breaker, verify that the motor cut off switches are properly adjusted. Charge the closing spring as described in Step 8 (roller resting on prop). Adjust each motor cut off switch so that they are depressed to the point where the main stem of the switch is located .015 minimum to .031 maximum from the threaded barrel, see Figure 11.

C. Control Circuit Modifications

1. Fig. 1 in GEK 7303 shows the existing control diagram. This circuit must be converted to the control circuit shown in Fig. 15. Wire terminals, splicing terminals, and wire are provided for this conversion.
2. The control circuit conversion requires the addition of the W and X relay. These relays are mounted on a common plate for easier assembly to the breaker. Wiring on and between these relays is factory installed. The W relay also has factory installed leads for the connections to the existing control relay.
3. The closing solenoid, which is mounted on the new motor operator, has 2 terminals that are electrically isolated from its coil. These terminals are used as connection points for the closing solenoid leads, the F switch lead and the motor lead. Refer to Fig. 16.

NOTE: Either motor lead or closing solenoid lead can be used as the neutral wire.

4. When the closing signal is given, this new control circuit will charge the closing spring and then discharge it closing the breaker. It will not allow the breaker to reclose unless another closing signal is given. The closing spring is not precharged.
5. The operation of this circuit is given below, refer to Fig. 15:

The closing signal energizes the new X1 relay through the existing relay and auxiliary switch contacts. The motor is then energized through the X1 and G contacts. The closing spring is charged until it activates the motor cut off unit, opening the G contacts and stopping the motor. The motor cut off unit also closes the F contacts one of which energizes the closing solenoid through the X1 contacts. The closing solenoid through its linkage removes the prop from the roller (see Fig. 9) discharging the closing spring, closing the breaker.

The X2 and W relays are energized through the remaining F contact and the D contact which is momentarily closed by the closing solenoid. The energized X2 relay opens the X1 relay circuit. When the X1 relay drops out, the charging motor circuit is opened. At this point, as long as the closing signal is applied, the X2 relay is energized through the W contact. This prevents the closing spring from being recharged.

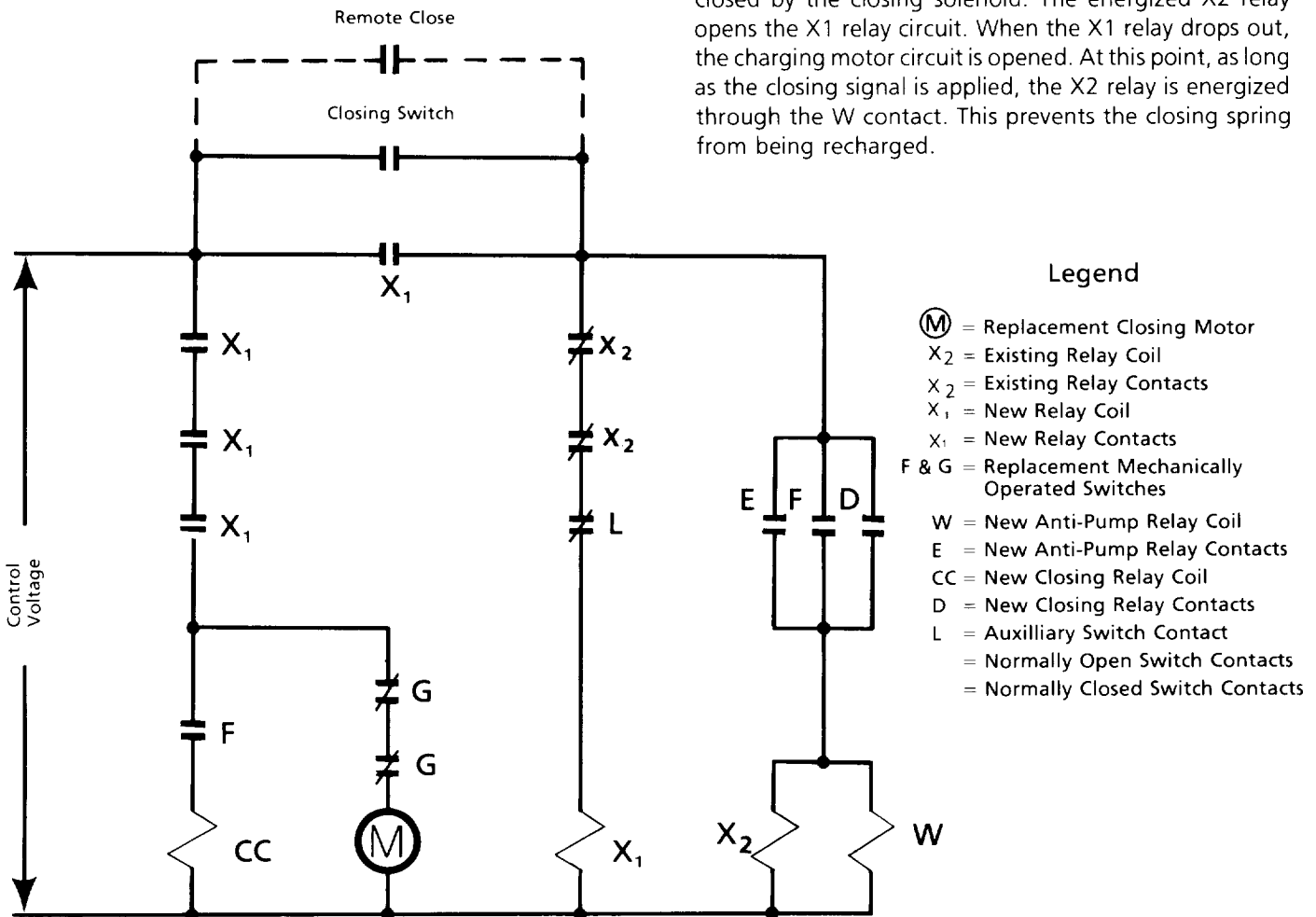

Fig. 15 — New control diagram for standard close breaker with replacement motor operator

IV. RENEWAL PARTS

Listed below are the catalog numbers for the various parts and assemblies included in these replacement motor operator kits. These components can be ordered through any General Electric Company office. Your order must include the quantity, catalog number and description.

A. Electrical Components

These components are recommended stock for normal maintenance.

| <u>Catalog Number</u> | <u>Description</u> |
|-----------------------|-----------------------------|
| See Table 3 | Closing Relay (X) |
| See Table 3 | Anti-pump Relay (W) |
| See Table 3 | Closing Solenoid (CC) |
| See Table 3 | Gear Motor (M) |
| 192A7153P3 | Closing Solenoid Switch (D) |
| 192A7153P7 | Cutoff Switch (F) |
| 192A7153P8 | Cutoff Switch (G) |

B. Mechanical Components

| <u>Catalog Number</u> | <u>Description</u> |
|-----------------------|---|
| 139C4369G2 | Spring Discharge Interlock AKD 5 Equipment |
| 139C4369G1 | Spring Discharge Interlock AKD/Stationary Equipment |
| 139C4452G1 | Motor Cutoff Switch ASM |
| 139C4485G28 | Right Side Support Assembly AKT 50 |
| 139C4485G26 | Right Side Support Assembly AK/AKU 50 |
| 425D278G1 | Motor Operator less Gear Motor |

Table 3 — Electrical Components

| Volts | Hertz | Closing Relay (X) | Anti-Pump Relay (W) | Closing Solenoid (CC) | Gear Motor |
|-------|-------|-------------------|---------------------|-----------------------|---------------|
| | | 192A9770 _____ | 192A9771 _____ | 192A9794 _____ | 568B596 _____ |
| 48 | DC | P1 | P1 | P11 | G4 |
| 125 | DC | P2 | P2 | P12 | G5 |
| 250 | DC | P3 | P3 | P13 | G6 |
| 120 | 60 | P4 | P4 | P14 | G5 |
| 120 | 50 | P5 | P4 | P15 | G5 |
| 120 | 25 | P10 | P7 | P18 | G5 |
| 208 | 60 | P6 | P5 | P16 | G6 |
| 208 | 50 | P7 | P5 | P17 | G6 |
| 208 | 25 | P11 | P8 | P19 | G6 |
| 240 | 60 | P8 | P6 | P16 | G6 |
| 240 | 50 | P9 | P6 | P17 | G6 |
| 240 | 25 | P12 | P9 | P19 | G6 |

