

## LINE TERMINATION

<u>Module</u>	<u>Description</u>
19D427353 G25	2W/4W, 3360Hz low-pass
19D427353 G26	2W/4W, 3960Hz low-pass
19D427535 G29	2W/4W, 2500Hz low-pass

### A. DESCRIPTION

The Line Termination module provides balanced isolated interfaces between the NS40 Audio Tone transmitter equipment and the transmission medium and between the transmission medium and NS40 receiver equipment. Each balanced interface contains a high pass filter that attenuates power frequency noise at 60 Hz.

The input to the module from transmitter equipment is on pin 5, a bridging input which will accept signals from one or more transmitters. A 15-turn variable resistor mounted on the front of the module is used to adjust the composite transmit line level. The signal then passes through the isolation transformer and the 60Hz filter.

The balanced input to the receive side of the unit is through the 60 Hz high pass filter components and through an active lowpass filter. The receive output level adjustment is a 15-turn variable resistor mounted on the front of the module.

Two-wire operation can be obtained on the Line A Transmit side by changing a jumper (jumper C) which effectively disables the receive input through Line B. The transmit signal is isolated from the receiver by the balanced hybrid transformer T1.

### B. OPERATION

Refer to Fig.3 - Schematic Diagram - and Fig.2 - Outline Diagram - which are included at the end of this instruction.

### Transmit path

The transmit input at pin 5 is designed to be driven from a 10K ohm source. Any number of inputs can be paralleled at pin 5. Variable gain stage AR1-1 amplifies the single or composite signal level which is measured across a 600 ohm load across pins 6 and 7. R2 sets the gain of the transmit circuit. Strappable jumper A adds 20 dB attenuation in the transmit path in the Low Output position (2-3). This strap should be used when composite signals below -20 dBm are desired. The 1-2 position is normal.

T1 is an isolation and unbalance-to-balance audio hybrid transformer at the input of the highpass filter. This highpass filter attenuates 60 Hz signals by at least 40 dB, passes 600 Hz and higher frequencies and is composed of components C2 through C8 and inductor L1. AR1-2 and associated components provide a termination for one side of the hybrid transformer T1. When jumper C is in the 1-2 position for 2-Wire operation, received signals are passed to the receive circuit and isolation is provided from transmitter signals by hybrid transformer T1 and the driving impedance (600 ohms) connected to Line A. The receive line B is disconnected in the 2-Wire case.

RV1 and RV3 are secondary surge protection devices.

The 600 ohm balanced output is on pins 6 and 7.

### Receive path

The Receive input is a balanced 600 ohms at pins 11 and 12 formed by the balanced highpass

filter which is identical to the filter in the Transmit side. The highpass filter is composed of components C9 through C15 and inductor L2. Isolation transformer T2 provides the balance-to-unbalance function. Zeners Z1 and Z2 serve as fast surge protection devices while MOV- RV2 performs secondary protection.

Amplifier AR2-1 is an isolation stage at the input of the active FDNR lowpass filter composed of resistors R38 through R56; capacitors C40 through C46; and op-amps AR2-2 through AR3-3. Amplifier AR3-4 is an isolation and gain stage at the output of the active lowpass filter.

The filter response is a seventh order Cauer lowpass with three finite poles. The filter has been adjusted at the factory and requires no user adjustments.

The filter in the G25 module passes frequencies up to 3360 Hz and attenuates frequencies from 3900 Hz to 8 kHz by at least 40 dB.

The filter in the G26 module passes frequencies up to 3960 Hz and attenuates frequencies from 4670 Hz to 8 kHz by at least 40 dB.

The filter in the G29 module passes frequencies up to 2500 Hz and attenuates frequencies from 2800 Hz to 8 kHz by at least 40 dB.

The composite level at the receive output is adjusted by R14 which is mounted on the front of the module. Strappable jumper B gives an additional 10 dB of fixed attenuation in the 2-3 position. The 1-2 position is normal.

### **C. NOMINAL OPERATING CHARACTERISTICS**

Transmitter Input	-10 dBsr per channel through a 10 Kilohm resistance
Line A Transmit	-45 to +8 dBm (composite)
Line B Receive	-30 to +10 dBm (composite)
Receive Output	-30 dBsr (*) per channel
Low-pass roll-off	Typically 1dB at cut-off frequency
“60Hz filter” loss	Typically 1dB (transmit or receive path)

(\*) 0dBsr = 778mVrms

ITEM NO.	IDENTIFICATION NUMBER	DESCRIPTION	GROUP NUMBER & QUANTITY								
			21	22	23	24	25	26	27	28	29
	19D427353G025 REV#02	LINE TERM,BI-DIR (STD)									
	19D427353G026 REV#02	LINE TERM,BI-DIR (SPEC)									
	19D427353G029 REV#02	LINE TERM,BI-DIR (SPEC)									
AR1	0246A9387P258	ULTRA-LOW NOISE						1	1		1
AR2	0246A9367P003	J-FET OP AMP						1	1		1
AR3	0246A9367P003	J-FET OP AMP						1	1		1
C1	0246A9036P684	CAP .68UF 50V 5% POLY						1	1		1
C2	0246A9036P103	CAP .01UF 50V 5% POLY						1	1		1
C3	0246A9036P684	CAP .68UF 50V 5% POLY						1	1		1
C4	0246A9036P684	CAP .68UF 50V 5% POLY						1	1		1
C5	0246A9036P684	CAP .68UF 50V 5% POLY						1	1		1
C6	0246A9036P684	CAP .68UF 50V 5% POLY						1	1		1
C7	0246A9037P105B	CAP 1MFD 400VDC 20%						1	1		1
C8	0246A9037P105B	CAP 1MFD 400VDC 20%						1	1		1
C9	0246A9037P105B	CAP 1MFD 400VDC 20%						1	1		1
C10	0246A9037P105B	CAP 1MFD 400VDC 20%						1	1		1
C11	0246A9036P684	CAP .68UF 50V 5% POLY						1	1		1
C12	0246A9036P684	CAP .68UF 50V 5% POLY						1	1		1
C13	0246A9036P684	CAP .68UF 50V 5% POLY						1	1		1
C14	0246A9036P684	CAP .68UF 50V 5% POLY						1	1		1
C15	0246A9036P103	CAP .01UF 50V 5% POLY						1	1		1
C16	0246A9009P151BM	CAP 150UF 20V 10% TANTX						1	1		1
C17	0246A9009P151BM	CAP 150UF 20V 10% TANTX						1	1		1
C18	0246A9036P103	CAP .01UF 50V 5% POLY						1	1		1
C19	0246A9036P103	CAP .01UF 50V 5% POLY						1	1		1
C20	0246A9036P103	CAP .01UF 50V 5% POLY						1	1		1
C21	0246A9006P102	CAP 1000PF 500V MICA						1	1		1
C30	0246A9040P226	CAP 22UF 35V 10% TANT						1	1		1
C31	0246A9040P226	CAP 22UF 35V 10% TANT						1	1		1
C32	0246A9040P226	CAP 22UF 35V 10% TANT						1	1		1
C33	0246A9040P226	CAP 22UF 35V 10% TANT						1	1		1
C40	5491871P3300G	CAP 3300PF 300V 2% MICA						1	1		1
C41	5491871P3300G	CAP 3300PF 300V 2% MICA						1	1		1
C42	5491871P3300G	CAP 3300PF 300V 2% MICA						1	1		1
C43	5491871P3300G	CAP 3300PF 300V 2% MICA						1	1		1
C44	5491871P3300G	CAP 3300PF 300V 2% MICA						1	1		1
C45	5491871P3300G	CAP 3300PF 300V 2% MICA						1	1		1
C46	5491871P3300G	CAP 3300PF 300V 2% MICA						1	1		1
L1	19B218975G004	COIL						1	1		1
L2	19B218975G004	COIL						1	1		1
R1	0246A9134P1002	RES 10K OHM 1/4W 1% MTL						1	1		1
R2	0246A9104P104	POT 100K .5W 10%						1	1		1
R3	0246A9134P1620	RES 162 OHM 1/4W 1%						1	1		1
R4	0246A9134P2430	RES 243 OHM 1/4W 1% MTL						1	1		1
R5	0246A9134P2371	RES 2.37KOHM 1/4W 1% MTL						1	1		1
R6	0246A9134P2490	RES 249 OHM 1/4W 1% MTL						1	1		1
R7	0246A9103P240	RESISTOR						1	1		1
R8	0246A9103P240	RESISTOR						1	1		1
R9	0246A9103P240	RESISTOR						1	1		1
R10	0246A9103P240	RESISTOR						1	1		1
R11	0246A9134P1501	RES 1.5K OHM 1/4W 1% MTL						1	1		1
R12	0246A9134P1501	RES 1.5K OHM 1/4W 1% MTL						1	1		1
R14	0246A9104P102	POT 1K .5W 10%						1	1		1
R15	0246A9134P22R1	RES						1	1		1
R16	0246A9102P100	RES 10 OHM .5W 5%						1	1		1
R17	0246A9102P100	RES 10 OHM .5W 5%						1	1		1
R18	0246A9134P6040	RES 604 OHM 1/4W 1% MTL						1	1		1
R19	0246A9134P2430	RES 243 OHM 1/4W 1% MTL						1	1		1
R20	0246A9134P9090	RES 909 OHM 1/4W 1% MTL						1	1		1
R22	0246A9134P6040	RES 604 OHM 1/4W 1% MTL						1	1		1
R23	0246A9134P6040	RES 604 OHM 1/4W 1% MTL						1	1		1
R24	0246A9134P2211	RES 2.21KOHM 1/4W 1% MTL						1	1		1
R25	0246A9134P1001	RES 1K OHM 1/4W 1% MTL						1	1		1
R29	0246A9134P1002	RES 10K OHM 1/4W 1% MTL						1	1		1
R36	0246A9134P1002	RES 10K OHM 1/4W 1% MTL						1	1		1
R37	0246A9134P1000	RES 100 OHM 1/4W 1% MTL						1	1		1
R38	0246A9134P1302	RES 13K OHM 1/4W 1% MTL						1	1		1
R38	0246A9134P1542	RES 15.4KOHM 1/4W 1% MTL						1	1		1
R38	0246A9134P2102	RES 21K OHM 1/4W 1% MTL						1	1		1
R39	0246A9134P1272	RES 12.7KOHM 1/4W 1% MTL						1	1		1
R39	0246A9134P7871	RES 7.87KOHM 1/4W 1% MTL						1	1		1
R39	0246A9134P9091	RES 9.09KOHM 1/4W 1% MTL						1	1		1
R40	0246A9134P1152	RES 11.5KOHM 1/4W 1% MTL						1	1		1

Figure 1 (19D427353) Parts List Line Termination, G25, G26 and G29

ITEM NO.	IDENTIFICATION NUMBER	DESCRIPTION	GROUP NUMBER & QUANTITY																	
			21	22	23	24	25	26	27	28	29									
R40	0246A9134P1402	RES 14K OHM 1/4W 1% MTL					1													
R40	0246A9134P1872	RES 18.7KOHM 1/4W 1% MTL																		1
R41	0246A9128P502	POT 5K 1/2W 10%					1		1										1	
R42	0246A9134P1212	RES 12.1KOHM 1/4W 1% MTL					1													
R42	0246A9134P1652	RES 16.5KOHM 1/4W 1% MTL																	1	
R42	0246A9134P9091	RES 9.09KOHM 1/4W 1% MTL								1										
R43	0246A9134P1152	RES 11.5KOHM 1/4W 1% MTL								1										
R43	0246A9134P1402	RES 14K OHM 1/4W 1% MTL						1												
R43	0246A9134P1872	RES 18.7KOHM 1/4W 1% MTL																	1	
R44	0246A9134P1152	RES 11.5KOHM 1/4W 1% MTL								1										
R44	0246A9134P1402	RES 14K OHM 1/4W 1% MTL						1												
R44	0246A9134P1872	RES 18.7KOHM 1/4W 1% MTL																	1	
R45	0246A9128P502	POT 5K 1/2W 10%						1		1									1	
R46	0246A9134P1652	RES 16.5KOHM 1/4W 1% MTL								1										
R46	0246A9134P2152	RES 21.5KOHM 1/4W 1% MTL						1												
R46	0246A9134P2942	RES 29.4KOHM 1/4W 1% MTL																	1	
R47	0246A9134P1152	RES 11.5KOHM 1/4W 1% MTL								1										
R47	0246A9134P1402	RES 14K OHM 1/4W 1% MTL						1												
R47	0246A9134P1872	RES 18.7KOHM 1/4W 1% MTL																	1	
R48	0246A9134P1072	RES 10.7K 1/4W 1%								1										
R48	0246A9134P1272	RES 12.7KOHM 1/4W 1% MTL						1												
R48	0246A9134P1742	RES 17.4KOHM 1/4W 1% MTL																	1	
R49	0246A9134P1622	RES 16.2KOHM 1/4W 1% MTL								1										
P49	0246A9134P1822	RES 18.2KOHM 1/4W 1% MTL						1												
R49	0246A9134P2612	RES 26.1KOHM 1/4W 1% MTL																	1	
P50	0246A9134P1152	RES 11.5KOHM 1/4W 1% MTL								1										
R50	0246A9134P1402	RES 14K OHM 1/4W 1% MTL						1												
R50	0246A9134P1872	RES 18.7KOHM 1/4W 1% MTL																	1	
R52	0246A9134P1102	RES 11K OHM 1/4W 1% MTL								1										
R52	0246A9134P1372	RES 13.7KOHM 1/4W 1% MTL						1												
R52	0246A9134P1822	RES 18.2KOHM 1/4W 1% MTL																	1	
R53	0246A9134P1152	RES 11.5KOHM 1/4W 1% MTL								1										
R53	0246A9134P1402	RES 14K OHM 1/4W 1% MTL						1												
R53	0246A9134P1872	RES 18.7KOHM 1/4W 1% MTL																	1	
R54	0246A9134P1102	RES 11K OHM 1/4W 1% MTL																		
R54	0246A9134P1332	RES 13.3KOHM 1/4W 1% MTL						1												
R54	0246A9134P1782	RES 17.8KOHM 1/4W 1% MTL																	1	
R55	0246A9134P3161	RES 3.16KOHM 1/4W 1% MTL								1										
R55	0246A9134P3831	RES 3.83KOHM 1/4W 1% MTL																		
R55	0246A9134P5491	RES 5.49KOHM 1/4W 1% MTL																	1	
R56	0246A9134P5111	RES 5.11KOHM 1/4W 1% MTL								1										
R56	0246A9134P6191	RES 6.19KOHM 1/4W 1% MTL						1												
R56	0246A9134P8451	RES 8.45KOHM 1/4W 1% MTL																	1	
RV1	0246A9433P002	DIODE						1		1									1	
RV2	0246A9433P002	DIODE						1		1									1	
RV3	0246A9433P002	DIODE						1		1									1	
T1	19B218976G003	XFMR						1		1									1	
T2	19B218976G003	XFMR						1		1									1	
W2	0246A9141P001	JUMPER .00 OHM RES						1		1									1	
Z1	0246A9427P6R8A	TRANSIENT SUPPRESSOR						1		1									1	
Z2	0246A9427P6R8A	TRANSIENT SUPPRESSOR						1		1									1	

Figure 1 (19D427353) Parts List Line Termination, G25, G26 and G29, continued

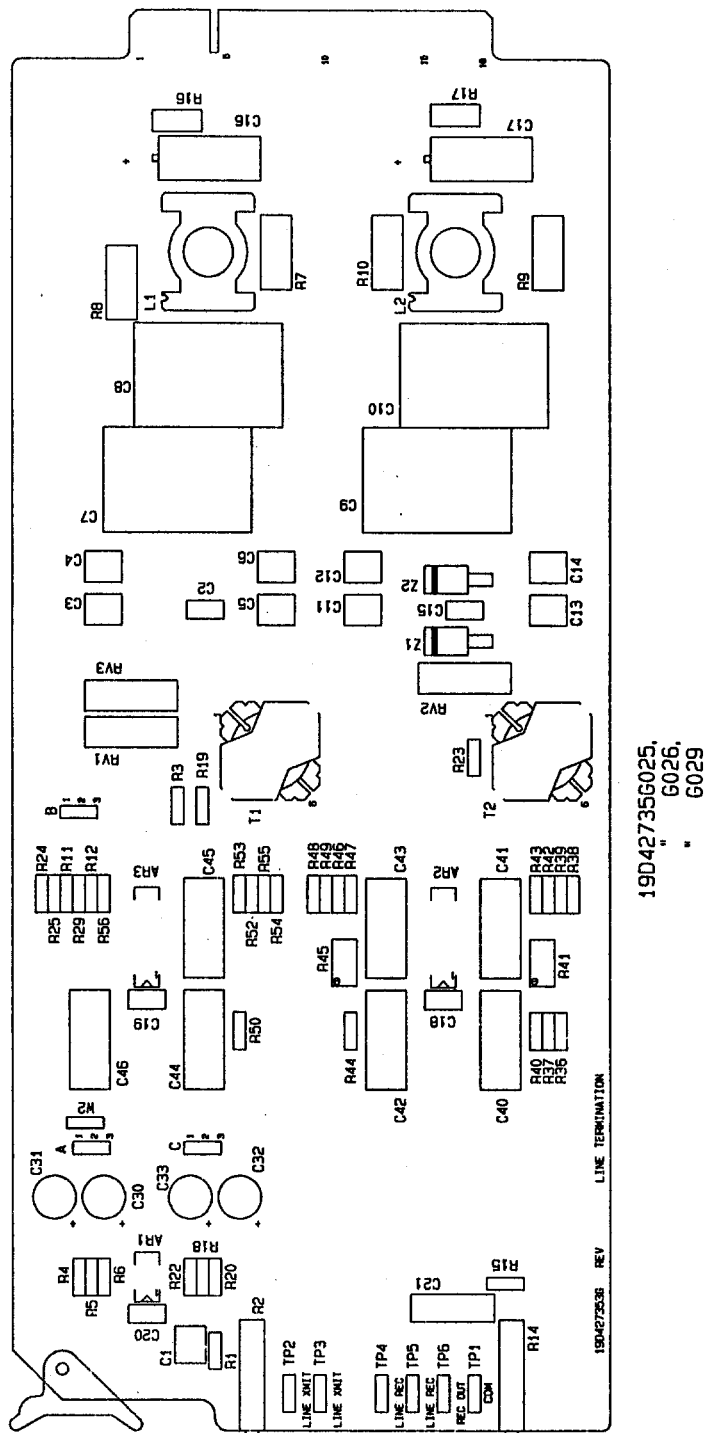
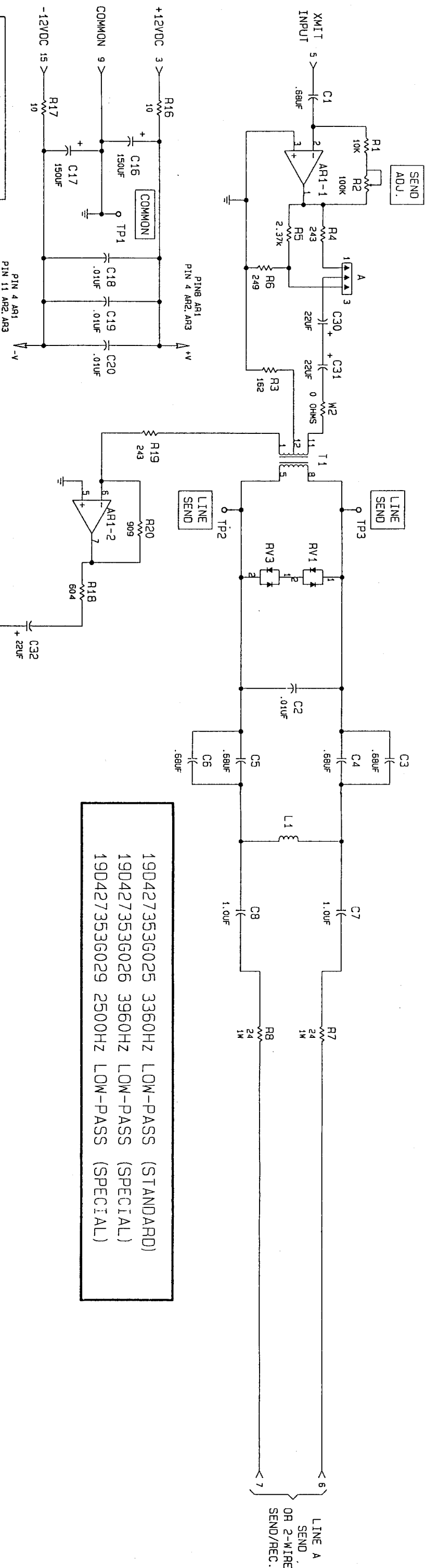
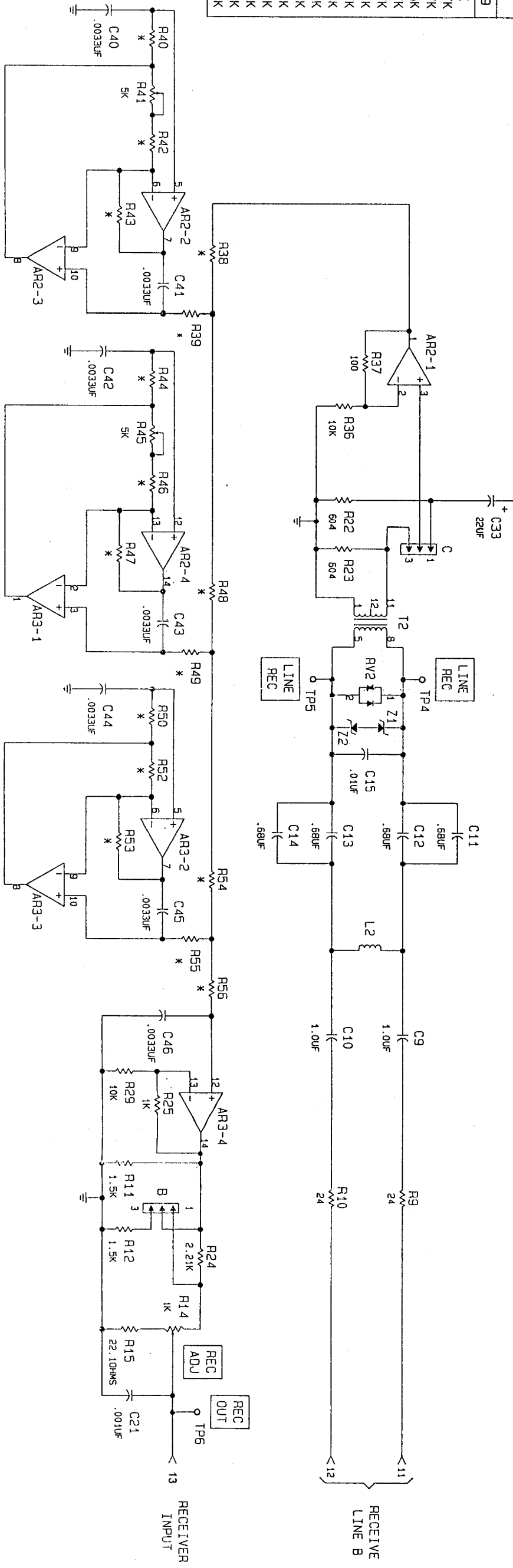

Figure 2 (0215B8763 Sh.1 [0]) Outline Diagram Line Termination, G25, G26 and G29



\* RESISTOR VALUES

GRP.	-025	-026	-029
R38	15.4K	13K	21K
R39	9.09K	7.87K	12.7K
R40	14K	11.5K	18.7K
R42	12.1K	9.09K	16.5K
R43	14K	11.5K	18.7K
R44	14K	11.5K	18.7K
R45	21.5K	16.5K	29.4K
R47	14K	11.5K	18.7K
R48	12.7K	10.7K	17.4K
R49	18.2K	16.2K	26.1K
R50	14K	11.5K	18.7K
R52	13.7K	11K	18.2K
R53	14K	11.5K	18.7K
R54	13.3K	11K	17.8K
R55	3.83K	3.16K	5.49K
R56	6.19K	5.11K	8.45K



JUMPER CHART

POS	FUNCTION
A	NORMAL
B	LOW OUTPUT
C	NORMAL
	10DB ATTEN.
	2-WIRE
	4-WIRE

Figure 3 (0145D8465Sh.3 [4]) Schematic Diagram  
Line Termination, G25, G26 and G29