

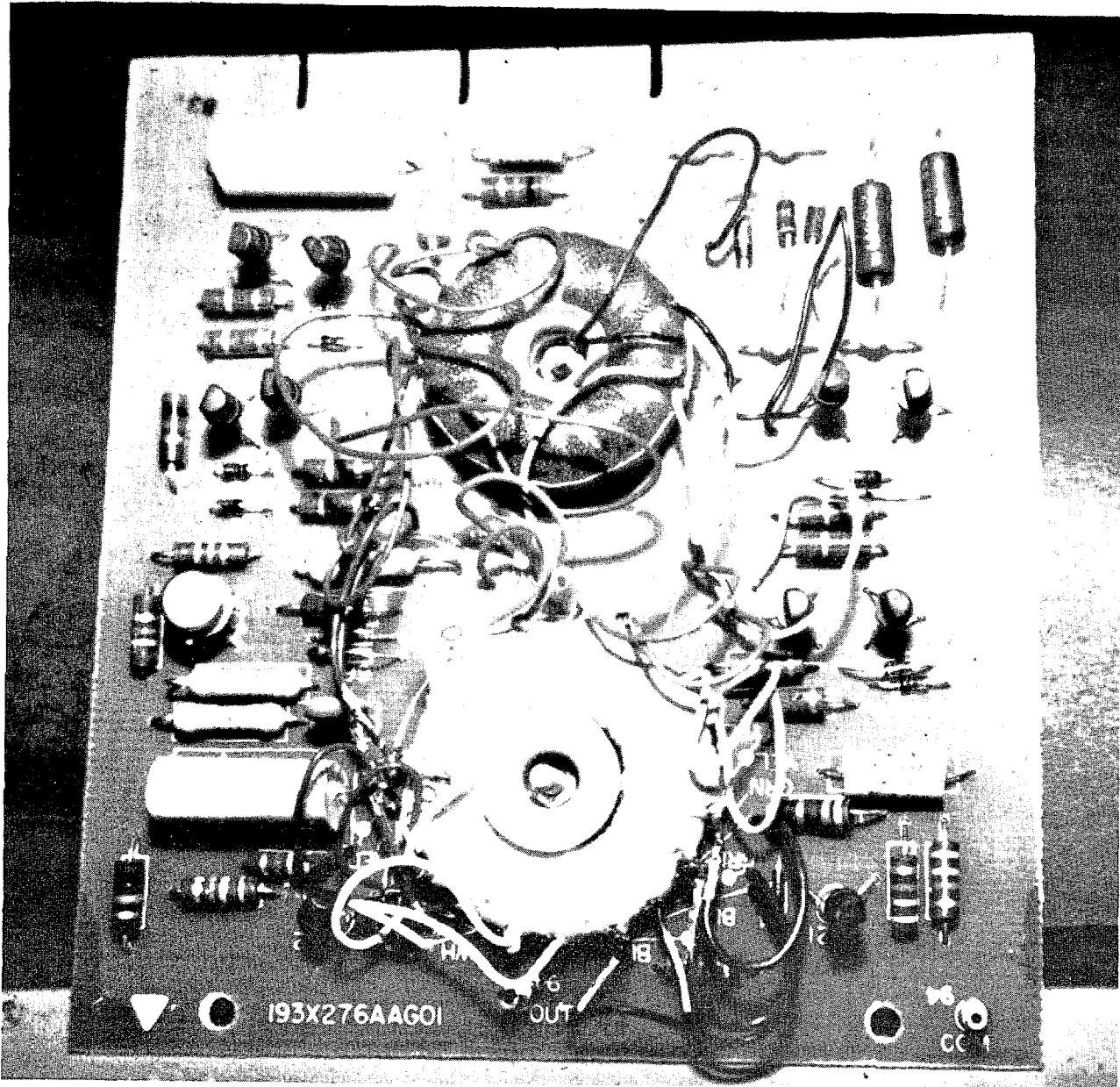

INSTRUCTIONS

GEK-24945A

SIGNAL ISOLATOR, 193X276A_G01



These instructions do not purport to cover all details or variations in equipment nor to provide for every possible contingency to be met in connection with installation, operation or maintenance. Should further information be desired or should particular problems arise which are not covered sufficiently for the purchaser's purposes, the matter should be referred to General Electric Company.

GENERAL  ELECTRIC

GEK-24945A (6/79) 2M (F)

INSTRUCTION

Signal Isolator, 193X276A_G01

1.0 GENERAL

This instruction provides the basic information required to checkout the Signal Isolator card. Refer to the system diagrams for information on how this card is used in the overall system.

2.0 DESCRIPTION

This card provides an output signal proportional to the input signal where the input signal and the output signal are isolated from each other and from the power input.

- 2.01 When the output load is less than 1 milliamp (1mA) the output at tabs 5 and 11 will be approximately .95 times the input at tabs 22 and 27. The output will be linear for inputs up to 20 volts.
- 2.02 An input clamp is provided to help protect the card against input voltages exceeding 20 volts.
- 2.03 The output may be filtered by connecting tab 10 to tab 11.

2.04 An operational amplifier is furnished for those cases where more than 1mA of output current is required. When this amplifier is used, the output will be limited to approximately 12 volts but it will provide up to 5mA of current. When this amplifier is used, -20 volts must be supplied to the card.

2.05 A test post is provided to monitor the output of the amplifier.

3.0 START—UP/CHECKOUT

Check that the amplifier output OUT is proper. There are no adjustments on this card.

4.0 TROUBLESHOOTING

Check that +20 volts is applied at tab 31. To check the isolator section, remove the output load and measure the input voltage between tabs 22 and 27 and the output voltage between tabs 5 and 11.

If the amplifier is used, check that -20 volts is applied to tab 2, and that any inputs at tab 6 are not causing the card to appear to malfunction.

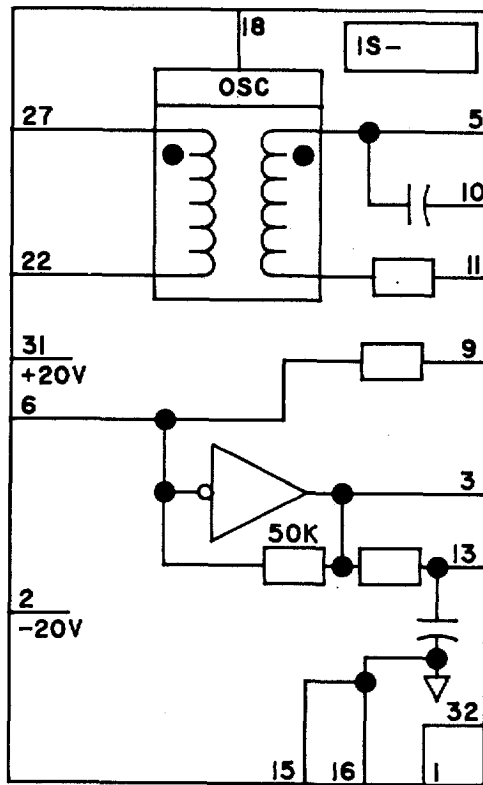

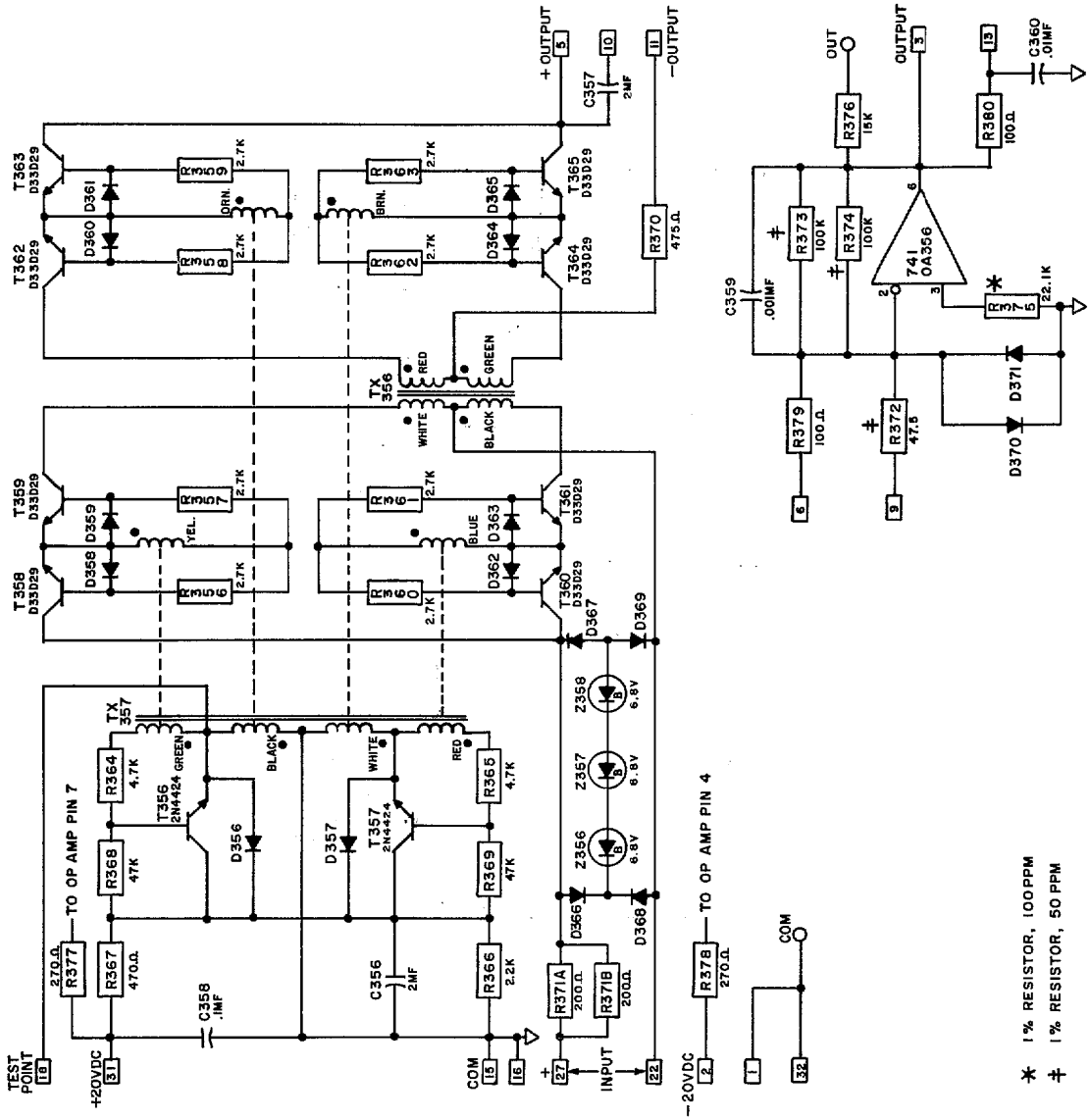

* 1% RESISTOR, 100 PPM
 † 1% RESISTOR, 50 PPM

GENERAL ELECTRIC COMPANY — DIRECT CURRENT MOTOR & GENERATOR PRODUCTS DEPARTMENT
ERIE, PENNSYLVANIA 16531

GENERAL  **ELECTRIC**