

3SRK1002 REVERSING OPTION WITH CONTACTOR FOR SWITCHING AUXILIARY FUNCTIONS

DESCRIPTION

This option consists of a small component board mounted on a bracket with 3 prewired contactors. In addition to allowing controlled torque plug reversing, this option provides an M contactor with a form C (SPDT) contact rated 30 amps resistive at 277 volts AC. The form C contact can be used to switch on AC motor, a motor clutch, a motor brake, or any other remote unit.

WARNING

The M contactor is picked up while the motor is stopped and dropped out while the motor is running, so when this option is used to switch a motor brake it is not possible to de-energize the brake in the event of contactor failure. Therefore, this contactor should not be used to switch a motor brake in applications in which personnel or equipment safety depend upon the contactor to de-energize the motor brake in the event of contactor failure.

INSTALLATION

For proper mounting location and orientation, refer to Figure 2 in instruction book GEK-36391. Hardware for securing the bracket to the controller chassis is provided with the option.

ELECTRICAL CONNECTIONS

Relay Coil Connections

The relay coil wiring is terminated in 2 connectors. The connector marked must be "REV" mated with the male connector marked "REV. CONN." and located on the controller main component board. The connector marked "M" must be mated with the male connector marked "M CONN." located on the controller main component board.

Power Circuit Connections

The motor armature circuit must be connected as shown in Figure 1. Refer to Figure 2 for terminal locations on the contactors. After the option has been

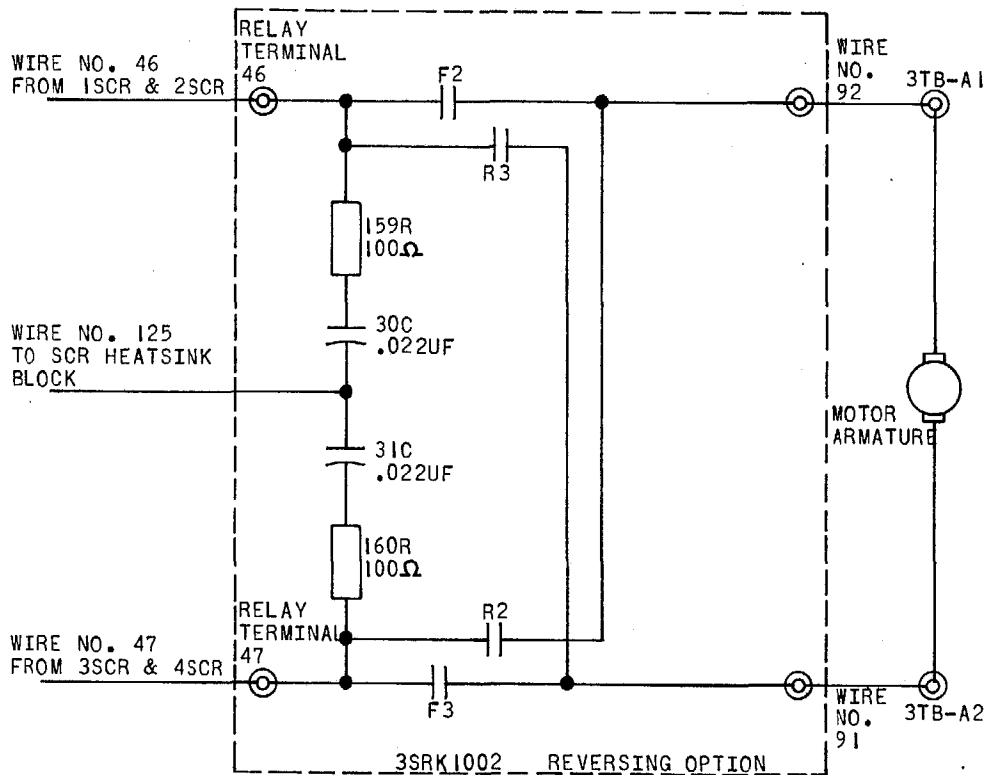

Figure 1. Motor Armature Circuit with 3SRK1002 Reversing Option Installed

These instructions do not purport to cover all details or variations in equipment nor to provide for every possible contingency to be met in connection with installation, operation or maintenance. Should further information be desired or should particular problems arise which are not covered sufficiently for the purchaser's purposes, the matter should be referred to General Electric Company.

mounted, proceed with the following connection sequence.

1. Locate wire number 46 (AWG 12) which runs from the SCR's to terminal 3TB-A1. NOTE: ON 3 HP UNITS, WIRE 46 RUNS FROM THE SCR'S TO THE INSULATED STAND-OFF AND THEN TO 3TB-A1. Disconnect this wire from 3TB-A1 and connect it to contactor terminal 46 on the reversing option (see Figure 2).

2. Locate wire number 47 (AWG 12) which runs from the SCR's to terminal 3TB-A2. Disconnect this wire from 3TB-A2 and connect it to contactor terminal 47 on the reversing option (see Figure 2).

3. Locate wire number 92 (AWG 12) which is factory connected to the reversing option. Connect the free end of wire number 92 to terminal 3TB-A1.

4. Locate wire number 91 (AWG 12) which is factory connected to the reversing option. Connect the free end of wire number 91 to terminal 3TB-A2.

5. Locate wire number 125 (AWG 18) which is factory connected to the reversing option. Connect the free end of wire number 125 to terminal 125 on the SCR heat sink block as shown in Figure 2.

When the reversing option is properly connected and when motor leads and controller terminals are connected A1 to A1, A2 to A2, F1 to F1, and F2 to F2, the motor will rotate CCW as viewed from the opposite shaft end when the control station button marked "FWD" is pressed.

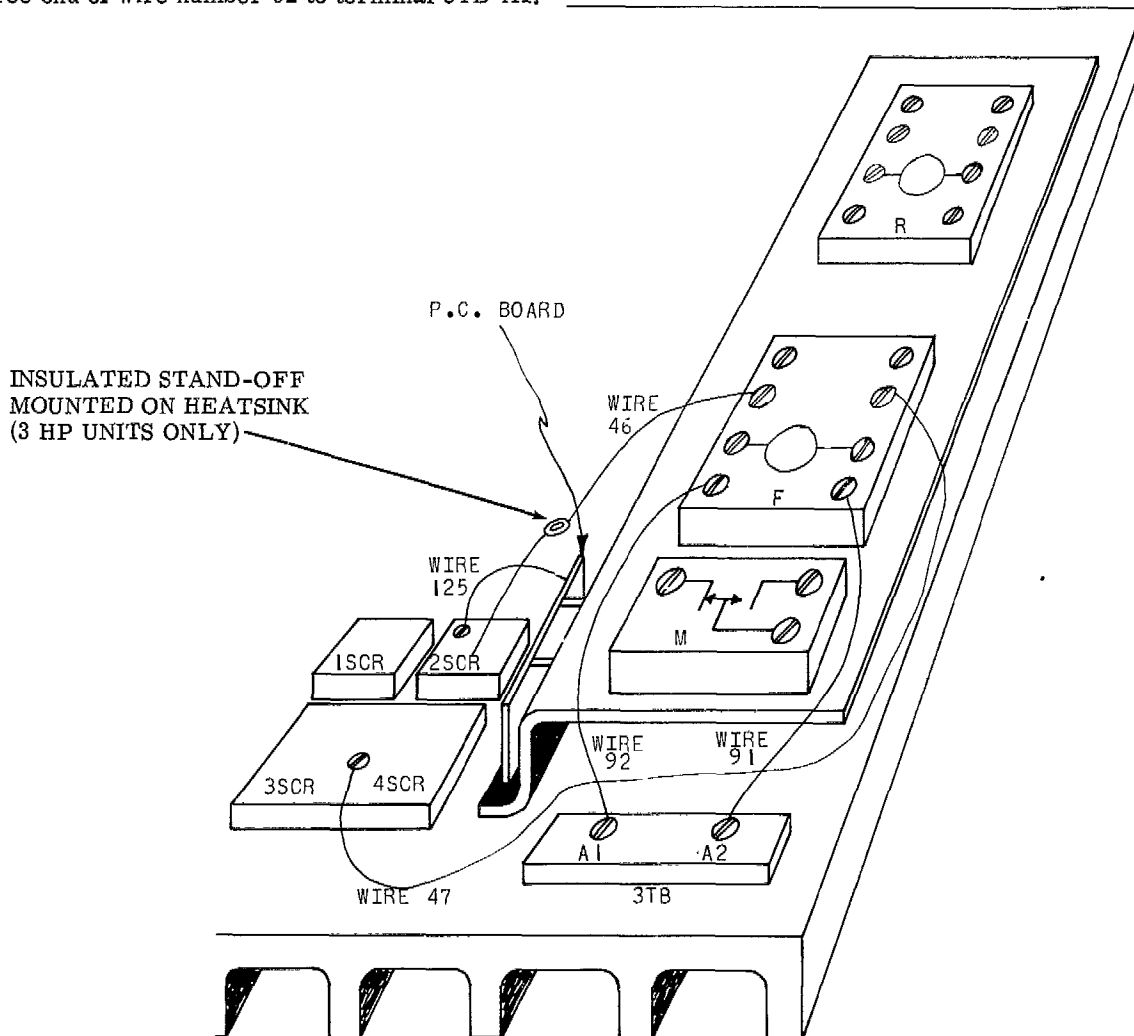

Figure 2. Customer Connection Diagram for 3SRK1002 Reversing Option