



INSTRUCTIONS

GEK-45487D

INSTANTANEOUS AUXILIARY RELAY

TYPE HGA111

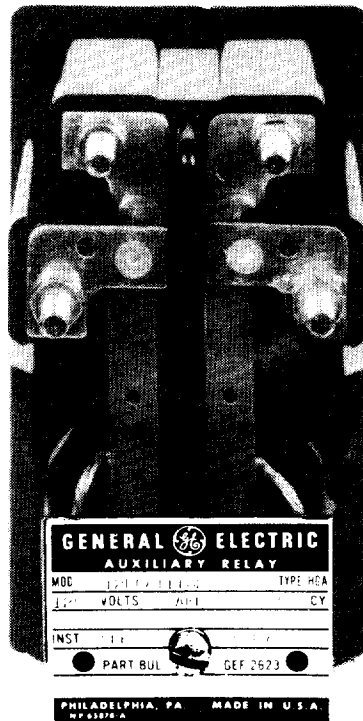

GENERAL  ELECTRIC

CONTENTS

	<u>PAGE</u>
DESCRIPTION.....	3
APPLICATION.....	3
RATINGS.....	3
BURDENS.....	3
CHARACTERISTICS.....	4
CONSTRUCTION.....	4
RECEIVING, HANDLING AND STORAGE.....	4
ACCEPTANCE TESTS.....	4
PICKUP TEST.....	4
MECHANICAL ADJUSTMENTS.....	5
PERIODIC CHECKS AND ROUTINE MAINTENANCE.....	5
CONTACT CLEANING.....	5
RENEWAL PARTS.....	5

FIG. 1 (8042734) COVER

INSTANTANEOUS AUXILIARY RELAY
TYPE HGA111
DESCRIPTION

RELAY TYPE	MOUNTING	CONNECTIONS	COVER	OUTLINE AND PANEL DRILLING	INTERNAL CONNECTIONS
HGA111A	SURFACE	BACK	SOLID	FIG.2	FIG.2
HGA111A(-)F	SEMI-FLUSH	BACK	GLASS	FIG.3	FIG.3
HGA111J	SURFACE	FRONT	SOLID	FIG.4	FIG.4
HGA111S	SURFACE	FRONT	SOLID	FIG.6	FIG.6

APPLICATION

The Type HGA111 relays covered by these instructions are hinged-armature auxiliary relays intended for use with protective relays to provide additional contacts, higher contact carrying and interrupting ratings, electrical separation of circuits, or other auxiliary functions. The relays are applicable where no intentional operating delay (over 1.75 to 2 cycles) is required and where the standard pickup values listed under ACCEPTANCE TESTS are acceptable.

RATINGS

The HGA111 relays are available with coil ratings for standard voltage up to 250 volts DC or for 120 and 240 volts 50 or 60 cycles. The coils are designed for long life even when operated continuously near maximum ambient temperature.

The current-closing rating of the contacts is 30 amperes. The current-carrying rating is 12 amperes continuously or 30 amperes for one minute. The interrupting ratings (non-inductive circuits) for the various voltages are listed in the following table:

DC					AC		
VOLTS	24	48	125	250	115	230	460
AMPS	12	6	1.5	0.5	25	15	5

BURDENS

D-C COILS		
VOLTS	RESISTANCE ± 10%	WATTS
250	15320	4.1
220	11655	4.2
125	3849	4.1
110	3036	4.0
62.5	1029	3.8
48	585	3.9
32	270	3.8
24	160	3.6
12	41	3.5
6	11	3.3

These instructions do not purport to cover all details or variations in equipment nor to provide for every possible contingency to be met in connection with installation, operation or maintenance. Should further information be desired or should particular problems arise which are not covered sufficiently for the purchaser's purposes, the matter should be referred to the General Electric-Company.

To the extent required the products described herein meet applicable ANSI, IEEE and NEMA standards; but no such assurance is given with respect to local codes and ordinances because they vary greatly.

Certain quantities should be defined before giving BURDEN DATA for a-c coils.

R_{DC} is the resistance of a coil as measured with an ohmmeter, bridge, etc.

R_{DO} is the a-c resistance of a coil when a-c power is flowing through the coil but the relay is not picked up. X_{DO} is the inductive impedance when the coil is energized but the relay is not picked up. The resistive and inductive parts of impedance of coil under picked up conditions are designated as R_{PU} and X_{PU} .

Z_{DO} is the impedance of the relay in dropout conditions. Z_{PU} is the impedance of the relay in picked up condition.

A-C COILS								
COILS	RATINGS	R_{DC}	R_{DO}	X_{DO}	Z_{DO}	R_{PU}	X_{PU}	Z_{PU}
VOLTS	CYCLE	$\pm 10\%$	$\pm 10\%$	$\pm 10\%$	$\pm 10\%$	$\pm 5\%$	$\pm 5\%$	$\pm 5\%$
120	60	98.5	159	549	572	437	909	1008
240	60	372	619	2063	2154	1694	3492	3881
120	50	136	293	512	590	538	951	1093
240	50	567	1225	2239	2552	2453	4165	4834

CHARACTERISTICS

HGA111 is a hinged armature type, high speed auxiliary relay. When the coil is energized, a magnetic flux flows through the armature pole piece and attracts the armature. Two auxiliary contacts are mechanically coupled to the armature. These auxiliary contacts can be normally open or normally closed types. These contacts can be used to make or break auxiliary circuits.

CONSTRUCTION

The HGA111 is a molded case relay. The various parts of the relay can be seen in Fig. 5. The control spring helps in adjusting the pickup and dropout voltage. The function of the voltage barrier is to avoid flashover between a pair of electrically separate but mechanically coupled normally closed contacts or between a pair of normally open contacts. Cover spring clips maintain a spring force against the cover to hold the cover in the correct position. The long life coils are capable of continuous operation near maximum ambient temperature.

RECEIVING, HANDLING AND STORAGE

These relays, when not included as part of a control panel, will be shipped in cartons designed to protect them against damage. Immediately upon receipt of a relay, examine it for any damage sustained in transit. If injury or damage resulting from rough handling is evident, file a damage claim at once with the transportation company and promptly notify the nearest General Electric Apparatus Sales Office.

Reasonable care should be exercised in unpacking the relay in order that none of the parts are injured or the adjustments disturbed.

If the relays are not to be installed immediately, they should be stored in their original cartons in a place that is free from moisture, dust and metallic chips. Foreign matter collected on the outside of the case may find its way inside when the cover is removed and cause trouble in the operation of the relay.

ACCEPTANCE TESTS

PICKUP TEST

Pickup is defined as the minimum voltage at which the armature operates and seals firmly against the pole piece. It is adjusted by means of the control spring which is fastened between the anchor pin and the armature tailpiece. The spring should be in the front hole of the anchor pin and the armature groove that gives the highest value of pickup without exceeding 80 percent of its rated a-c volts or 60 percent of rated d-c volts.

The a-c voltage relays are adjusted to pick up at 70-80 percent of rating at rated frequency. The d-c voltage relays are adjusted to pick up at 50-60 percent of rating when cold.

The pickup and dropout voltages for a-c relays, after being continuously energized for a few hours (minimum 4 hours) at rated voltage, increase by 3.5 percent to 7.5 percent. In the case of d-c relays, the pickup and dropout voltages increase by 5 percent to 10 percent.

The wipe on HGA111 relays exerts a contact pressure of 35 grams \pm 10 percent on "a" contacts and 10 grams \pm 10 percent on "b" contacts.

MECHANICAL ADJUSTMENTS

There should be at least 1/16 inch wipe on the normally closed "b" contacts and the normally open "a" contacts as measured at the top of the moving contact carrier. To determine, operate the armature by hand and check that there is at least 1/16 inch movement of the top edge of the contact carrier after the contacts have made.

When the armature is operated by hand, the "a" contacts should make within 1/32 inch of each other i.e., with one contact just making, the gap of the other should never be more than 1/32 inch. This also applies to the "b" contacts.

For all back connected relays with cover, check that there is at least 1/32 inch clearance between the armature tailpiece and the bottom inside surface of the cover. There is a special cover with cutouts in the sides available to check this clearance.

PERIODIC CHECKS AND ROUTINE MAINTENANCE

In view of the vital role of relays in the operation of a power system, it is important that a periodic test program be followed. It is recognized that the interval between periodic checks will vary depending upon environment, type of relay and the user's experience with periodic testing. Until the user has accumulated enough experience to select the test interval best suited to his individual requirements it is suggested that the points listed under ACCEPTANCE TESTS be checked on the same schedule as the associated protective relays.

CONTACT CLEANING

For cleaning relay contacts, a flexible burnishing tool should be used. This consists of a flexible strip of metal with an etched-roughened surface resembling in effect a superfine file. The polishing action is so delicate that no scratches are left, yet it will clean off any corrosion thoroughly and rapidly. Its flexibility ensures cleaning of the actual points of contact. Do not use knives, files, abrasive paper or cloth of any kind to clean relay contacts.

RENEWAL PARTS

It is recommended that sufficient quantities of renewal parts be carried in stock to enable the prompt replacement of any that are worn, broken, or damaged.

When ordering renewal parts, address the nearest Sales Office of the General Electric Company, specify quantity required, name of the part wanted, and the complete model number of the relay for which the part is required.

Since the last edition, Relay HGA111S has been added, with Figure 6.

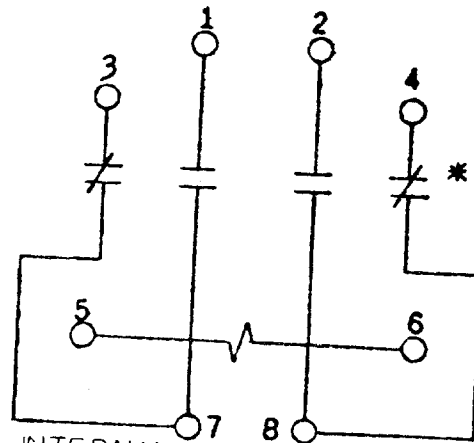
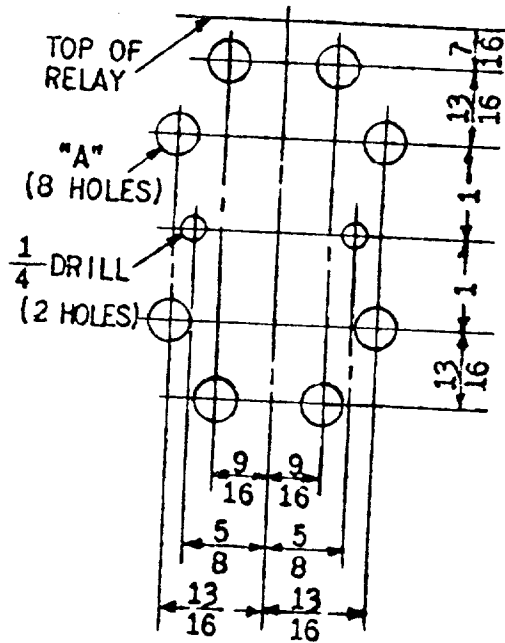
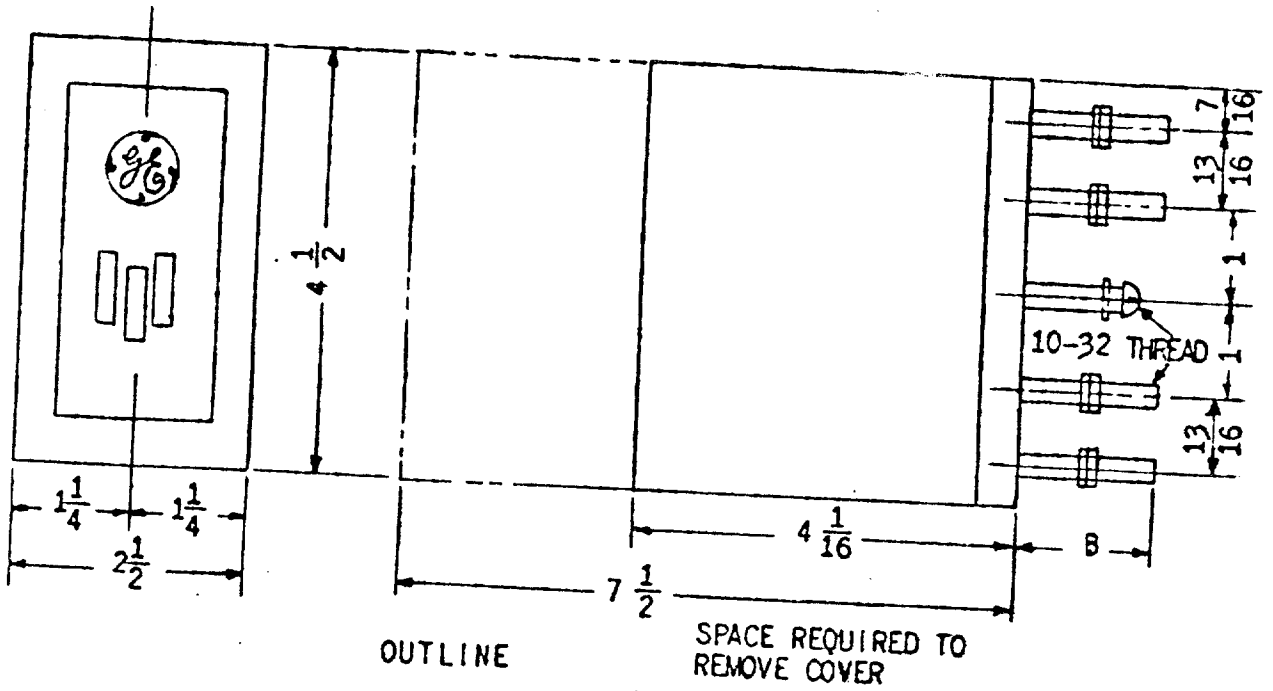

* = WITH HGAI4A, I4J, I4K, I4N, I7A CONTACT 4 IS NOT USED UNLESS PICKUP IS RAISED TO 60% (DC) OR 80% (AC) OF RATING HGCI1A DOES NOT USED CONTACT 4.

TYPE OF PANEL	"A"	"B"
INSULATING	7/16"	2-13/16"
STEEL	9/16"	1-3/8"

PANEL DRILLING (FRONT VIEW)

DUPLICATE OF LOST ORIGINAL TRACING

FIG. 2 (K-6077058-20) OUTLINE AND PANEL DRILLING FOR HGAI11A RELAYS.

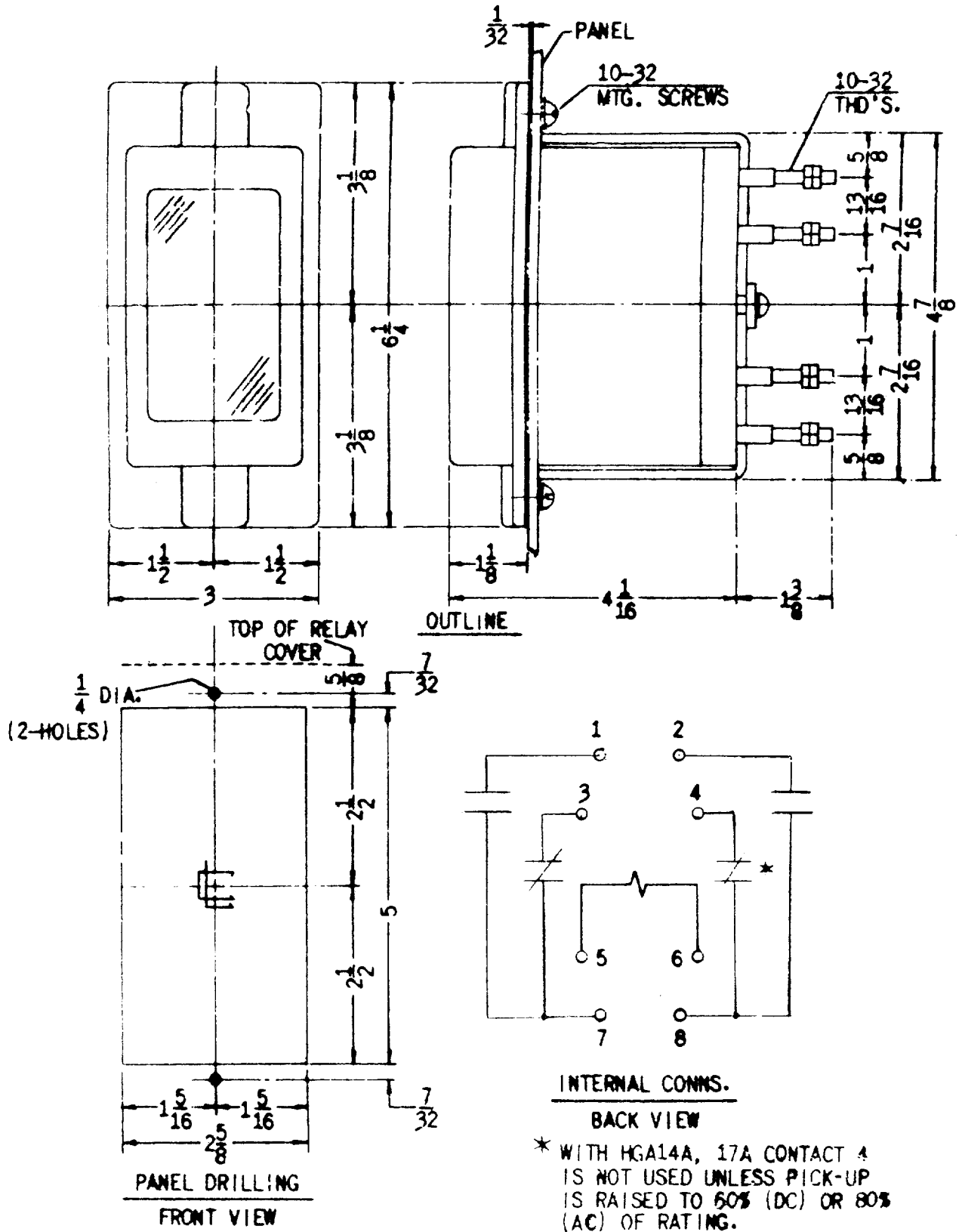

INTERNAL CONNS.
 BACK VIEW
 * WITH HGA14A, 17A CONTACT 4 IS NOT USED UNLESS PICK-UP IS RAISED TO 50% (DC) OR 80% (AC) OF RATING.

FIG. 3 (0104A8557-2) OUTLINE AND PANEL DRILLING FOR HGA111A *F RELAYS.

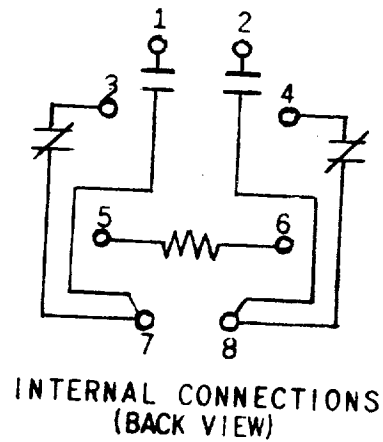
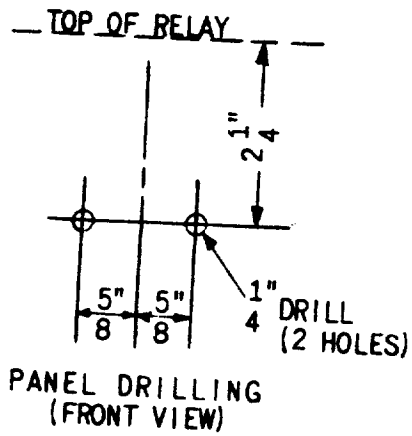
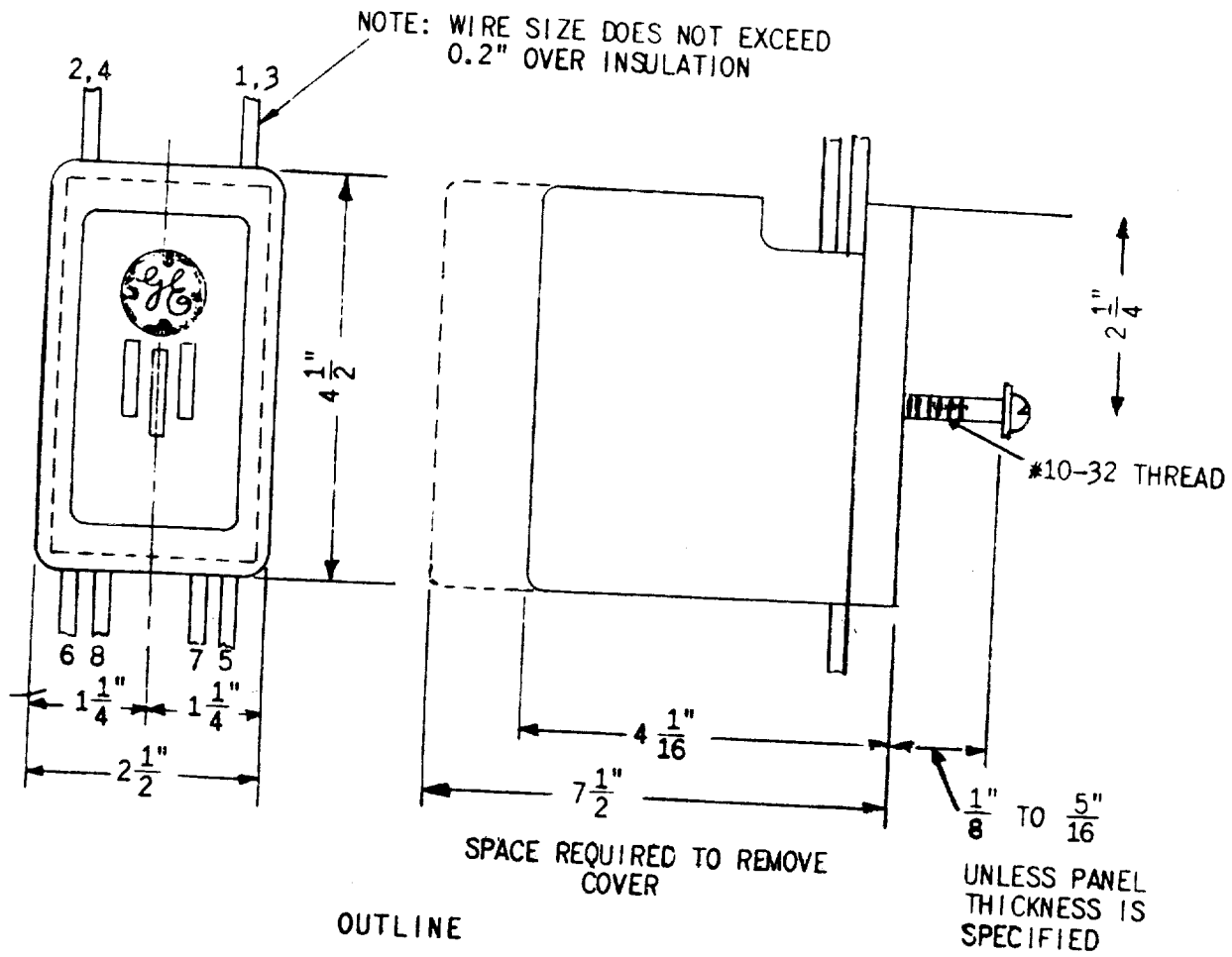

FIG. 4 (K-6375626-4) OUTLINE AND PANEL DRILLING FOR HGA111J RELAYS.

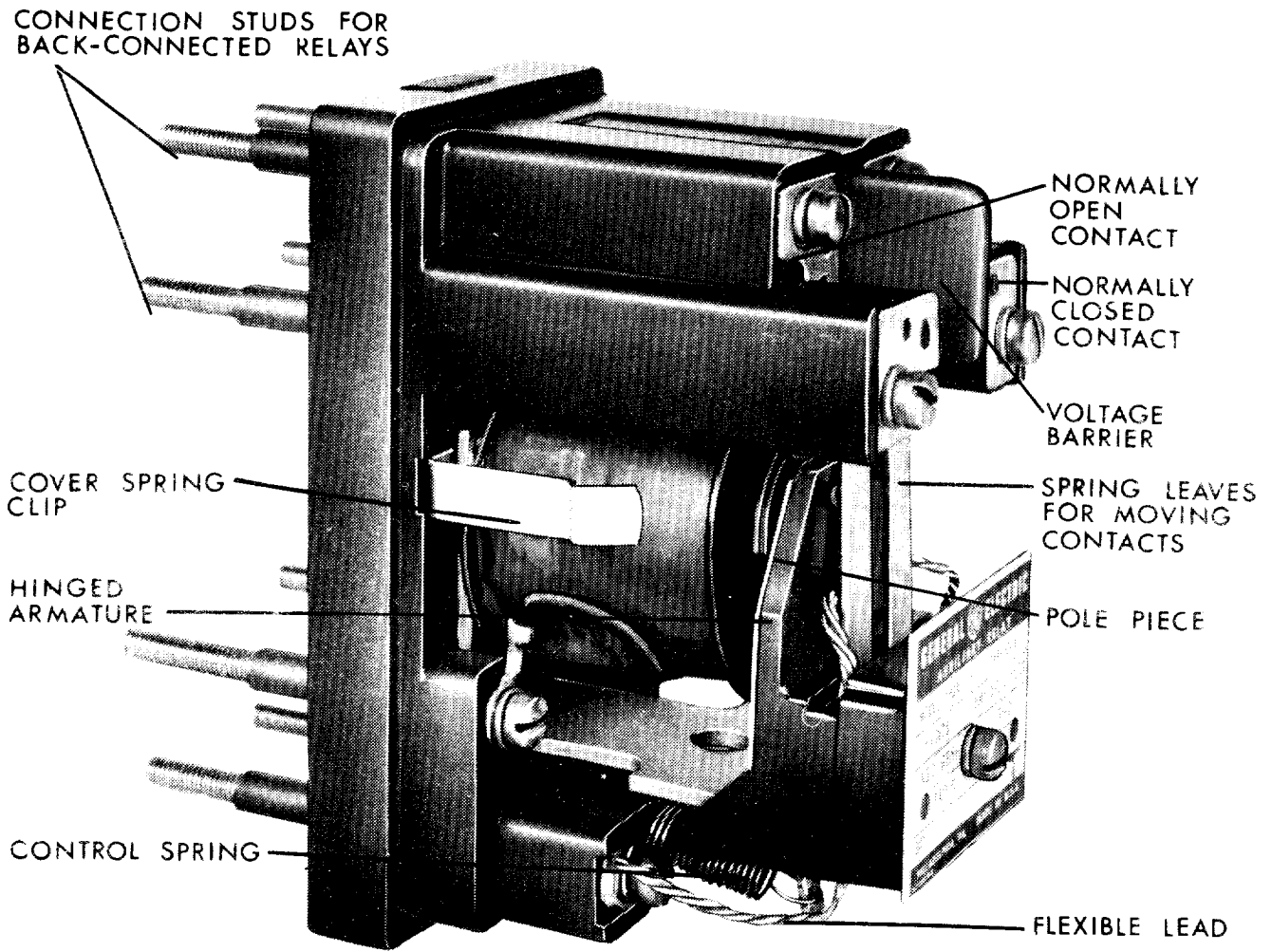

FIG. 5 (8042422) TYPICAL TYPE HGA RELAY REMOVED FROM CASE.

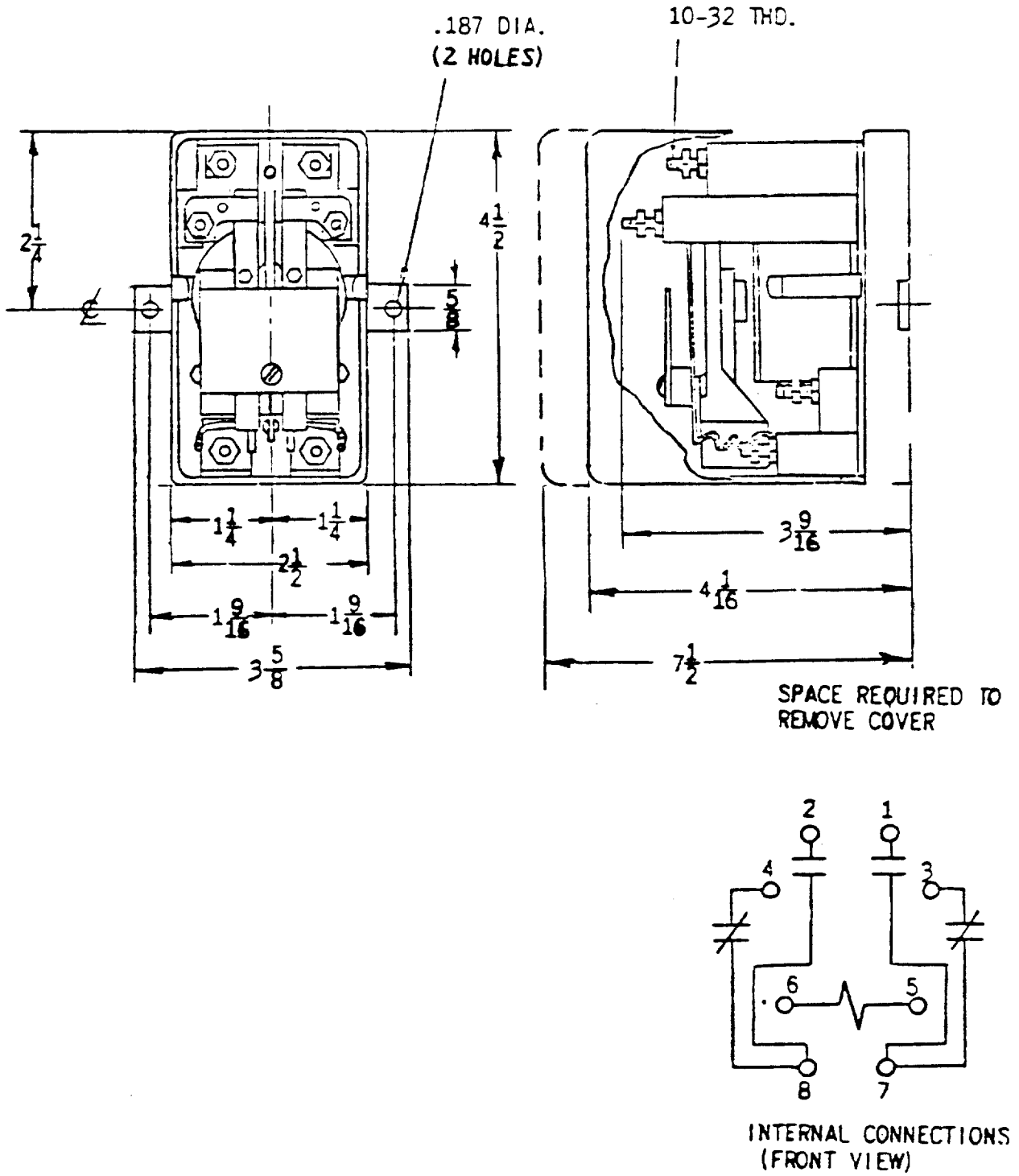

FIG. 6 (0165A7757 [2]) OUTLINE AND PANEL DRILLING FOR HGA111S RELAYS.



GE Power Management

**215 Anderson Avenue
Markham, Ontario
Canada L6E 1B3
Tel: (905) 294-6222
Fax: (905) 201-2098
www.ge.com/indsys/pm**