

**INSTRUCTIONS**

**GEH-1767C**

# **DIRECTIONAL OVERCURRENT RELAYS**

**Types**

**JBC51N JBCG51N  
JBC52N JBCG52N  
JBCV51N**

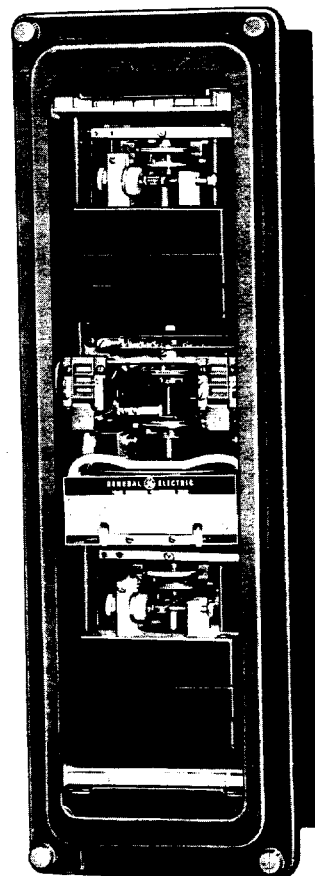

**LOW VOLTAGE SWITCHGEAR DEPARTMENT**

**GENERAL  ELECTRIC**

**PHILADELPHIA, PA.**

**NOTES**

# CONTENTS

	PAGE
INTRODUCTION .....	5
APPLICATION .....	5
Phase Faults - JBC .....	5
Phase Faults - JBCV .....	5
Ground Faults - JBCG .....	5
Time Overcurrent Unit .....	7
OPERATING CHARACTERISTICS .....	7
Directional Unit .....	7
Time Overcurrent Unit .....	9
Instantaneous Unit .....	9
RATINGS .....	9
Contacts .....	12
Seal-in Unit .....	12
BURDENS .....	13
RECEIVING, HANDLING AND STORAGE .....	14
DESCRIPTION .....	14
DIRECTIONAL UNIT .....	14
INSTANTANEOUS OVERCURRENT UNIT .....	14
TIME OVERCURRENT UNIT .....	14
SEAL-IN UNIT .....	15
CONTACTS .....	15
CASE .....	15
INSTALLATION .....	17
LOCATION .....	17
MOUNTING .....	17
CONNECTIONS .....	17
INSPECTION .....	17
OPERATION .....	17
ADJUSTMENTS .....	18
TIME OVERCURRENT UNIT .....	18
Target and Seal-in Unit (Marked "T") .....	18
Current Setting .....	18
Time Setting .....	18
Example of Setting .....	18
INSTANTANEOUS OVERCURRENT UNIT .....	18
Target and Seal-in Unit (Marked "T") .....	18
Pickup Setting .....	18
DIRECTIONAL UNIT .....	19
Polarity Check .....	19
MAINTENANCE .....	20
DIRECTIONAL UNIT .....	20
Torque Adjustment .....	20
Clutch Adjustment .....	20
Bearings .....	21
Cup and Stator .....	21
Contact Adjustment .....	21
INSTANTANEOUS OVERCURRENT UNIT .....	21
Torque Adjustment .....	21
Clutch Adjustment .....	21
Bearings .....	21
Cup and Stator .....	22
Contact Adjustment .....	22
TIME OVERCURRENT UNIT .....	22
Disk and Bearings .....	22
Contact Adjustment .....	22
CONTACT CLEANING .....	22
PERIODIC TESTING .....	22
RENEWAL PARTS .....	22

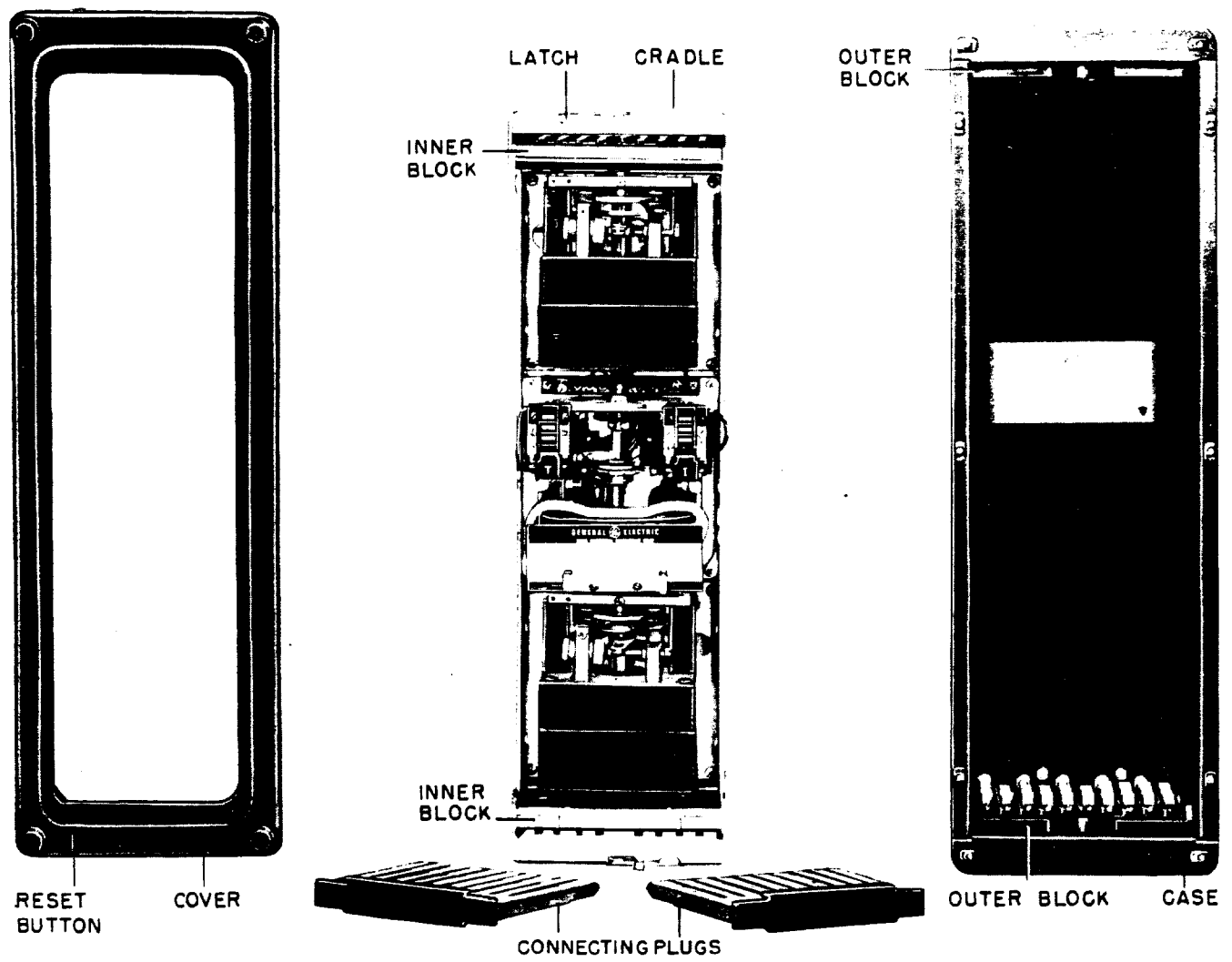

Fig. 1 Type JBCV51N Relay - Disassembled (Front View)

# DIRECTIONAL OVERCURRENT RELAYS

## INVERSE TIME CHARACTERISTICS

### TYPES JBC, JBCG, AND JBCV

## INTRODUCTION

The relays of the JBC type are directional overcurrent relays that are employed primarily for the protection of feeders and transmission lines against faults in applications where single-phase relays, instead of polyphase power-directional relays, are desired or required.

The Types JBC, JBCG and JBCV relays, of the inverse time characteristic, consist of three units, an instantaneous power directional unit (bottom) of the induction-cup type, an inverse time overcurrent unit (middle) of the induction-disk type, and an instantaneous overcurrent unit (top) of the induction-cup type. The directional-unit contacts control the operation of both the instantaneous and the time overcurrent units (directional control).

## APPLICATION

### PHASE FAULTS - JBC

The Type JBC relays are frequently applied for phase-fault protection of a single line. The quadrature or 90-degree connection is recommended for this application, as it provides the most reliable operation during usual fault conditions. External connections of current and potential transformers are shown in Fig. 2. With this connection, the current (at unity-power-factor load) leads the polarizing potential by 90 degrees. Since the directional unit has a 45-degree characteristic, its maximum torque will occur when the fault current (balanced 3-phase fault) lags its unity-power-factor position by 45 degrees.

When phase relays are used in conjunction with a potential-polarized ground relay, it is necessary for the potential transformer primaries to be connected in wye. Since only the quadrature connection is recommended for the Type JBC relays, an auxiliary wye-broken-delta transformer should be used in conjunction with wye-wye potential transformers, as typified by the external connections in Fig. 3.

### PHASE FAULTS - JBCV

The Type JBCV relay is applied for phase-fault protection when it is necessary to distinguish between fault conditions and overload or power swings. The voltage restraint feature of the relay makes this distinction possible. Fig. 6 shows the effect of voltage restraint on the impedance characteristic of this relay as compared with that of the Type JBC relay.

When the generation at a given station is apt to vary from time to time, it is possible that the maximum load current may exceed the minimum fault current. When this occurs the Type JBC relay will not distinguish between a heavy load with maximum generation and a fault with minimum generation. This is a typical application for the Type

JBCV relay. When a fault occurs with minimum generation, the restraint torque in the directional unit collapses rapidly as the voltage drops, thus permitting the relay to trip at the low value of fault current. On the other hand, the relay is prevented from tripping on heavy load currents with maximum generation as the directional unit will not pick up due to the system voltage being maintained.

Long or heavily loaded lines, that are operating near the stability limit, are subject to severe power swings. These power swings appear to the relay as traveling faults. Since the voltage is maintained near normal during a power swing, the area on the impedance diagram, within which the fault must remain to cause tripping, is somewhat smaller with the Type JBCV relay than it would be for a relay without voltage restraint.

Typical connections for the Type JBCV relay with voltage restraint are shown in Fig. 4. If voltage restraint is removed, the relay will be similar to a Type JBC relay having a quadrature connection.

### GROUND FAULTS - JBCG

The schemes previously described protect against phase-to-phase and polyphase short circuits. They also protect against ground faults if the ground current is not limited to a value too small to operate the relay. For cases where the ground current is limited (either by resistance in the system ground or by the system characteristics) to values that will not operate the phase relays, a ground relay should be provided as shown in Figs. 3 and 5. The relays used for ground fault protection usually have a low-range operating coil which may be rated 0.5/2 or 1.5/6 ampere (the 4/16 ampere rating is also available). They may be either potential or current polarized, and the Type JBCG relays covered by these instructions can be polarized by either means. Normally, no current flows in either the operating or current-polarizing coils of the ground relay, nor is there voltage across the potential polarizing coils.

Fig. 3 shows the external connections for the Type JBCG ground relay when used in conjunction with phase relays polarized from wye-wye potential transformer. The polarizing voltage for the ground relay is obtained by means of an auxiliary wye-broken-delta potential transformer. Either Type JBC or Type JBCV phase relays can be used with this scheme.

Fig. 5 shows the typical external connections for the Type JBCG ground relay when current polarized from a local source of ground current. On some applications, system conditions may at one time be such that potential polarization of ground relays is desirable and at another be such that current polarization would be preferred. The Type JBCG relay with its feature of dual polarization is

*These instructions do not purport to cover all details or variations in equipment nor to provide for every possible contingency to be met in connection with installation, operation or maintenance. Should further information be desired or should particular problems arise which are not covered sufficiently for the purchaser's purposes, the matter should be referred to the General Electric Company.*

**GEH-1767 Directional Overcurrent Relays Types JBC, JBCG, And JBCV**

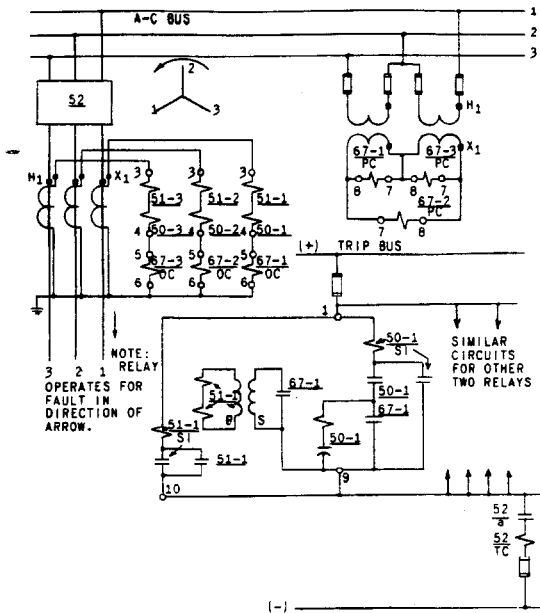

**DEVICE FUNCTION NUMBERS FOR USE WITH EXTERNAL DIAGRAMS**

- 50 - Instantaneous Unit
- 51 - Time Overcurrent Unit
- 52 - Power Circuit Breaker
- 67 - Directional Unit
- a - Aux. Contact, Closed when breaker closes
- OC - Operating Coil
- SI - Seal-in With Target
- TC - Trip Coil
- RC - Restraining Coil

**Fig. 2 The 90-Degree Connection Three Type JBC51M Relays Used For The Directional Overcurrent Protection Of A Single Line**

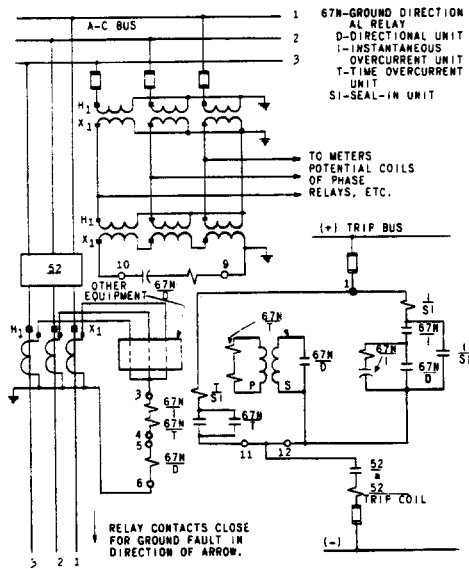

**Fig. 3 Directional Ground Protection Of A Single Line Using The Type JBC65M Relay With Potential Polarization From A Wye-Broken-Delta Auxiliary Transformer**

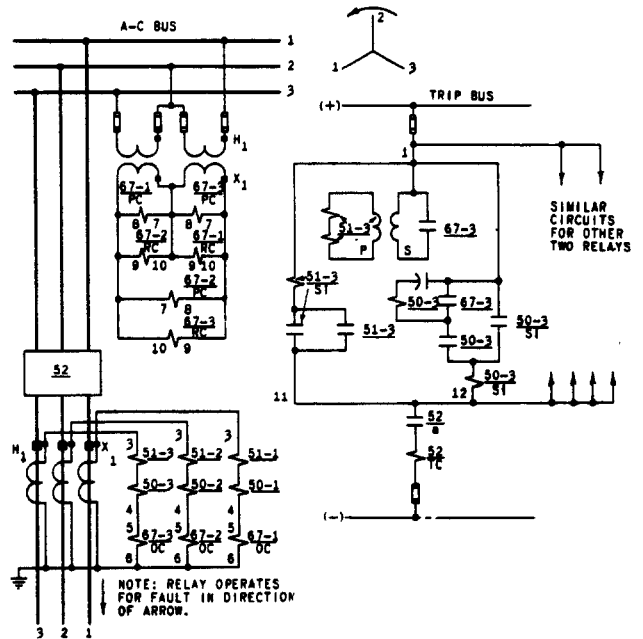

**Fig. 4 Typical External Connections For Directional Overcurrent Protection Of A Line Using Three Type JBCV51M Relays**

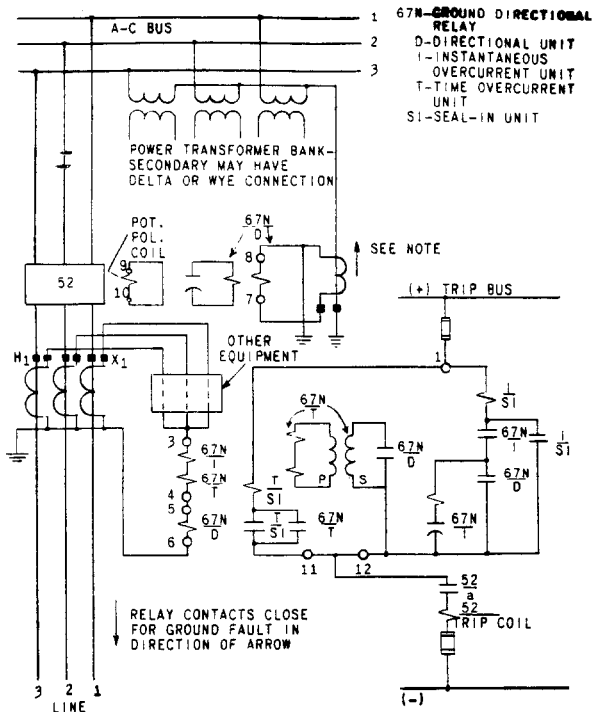

Fig. 5 Direction Ground Protection Of A Single Line Using A Type JBCG51N Relay With Current Polarization

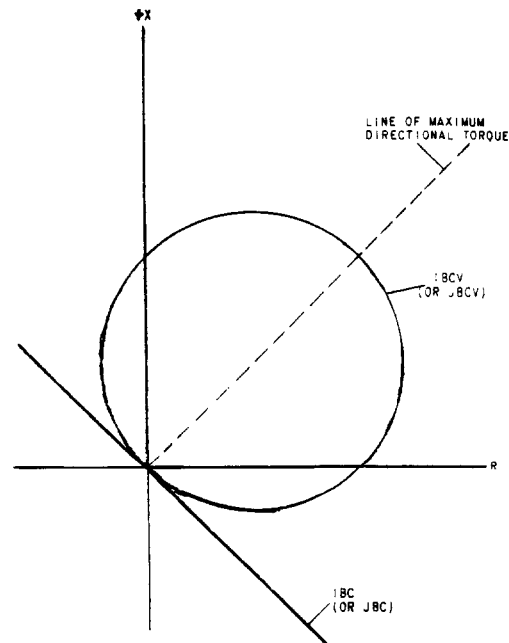

Fig. 6 Impedance Characteristics Of The Type JBC And JBCV Relays

well suited for such applications. The curves in Fig. 7 compare the performance of the dual polarized relay with that of potential and current-polarized relays for such an application.

#### TIME OVERCURRENT UNIT

On systems where the magnitude of fault current flowing through a given relay is dependent mainly upon the location of the fault relative to the relay, and only slightly or not at all upon the system generating setup, best results are usually obtained with very-inverse-time relays. In cases where the fault current magnitude is influenced largely by the systems generating capacity at the time of the fault, best results will be obtained if relays with inverse time characteristics, covered by these instructions, are used.

The reason for this is that relays must be set to be selective with maximum fault current flowing. For currents below this value, the time becomes greater as the current is decreased. If there is a wide range in generating capacity, together with variation in short-circuit current with fault position, the operating time with minimum fault current may be exceedingly long with very-inverse-time relays. For such cases the inverse-time relay is recommended.

#### OPERATING CHARACTERISTICS

The Type JBC51N relay is a potential-polarized phase relay having single circuit-closing contacts

on both the time and instantaneous overcurrent units.

The Type JBC52N relay is similar to the Type JBC51N relay except that both the time and instantaneous overcurrent units have two circuit-closing contacts.

The Type JBCV51N relay is also a potential-polarized phase relay similar to the Type JBC51N relay except that its directional unit is provided with a voltage restraint feature. If the restraint circuit is disconnected, the relay will be equivalent to the Type JBC51N relay with maximum torque at 45 degrees lead.

The Type JBCG51N relay is a dual-polarized ground relay having single circuit-closing contacts on both the time and instantaneous overcurrent units. The directional unit is provided with two sets of polarizing coils which permit it to be polarized from a potential source or from a local ground current source, or from both simultaneously.

The Type JBCG52N relay is similar to the Type JBCG51N relay except that its overcurrent units each have two circuit-closing contacts.

The distinguishing features of the various relays have been summarized for convenience in Table I.

#### DIRECTIONAL UNIT

The directional unit of the Type JBC relays will

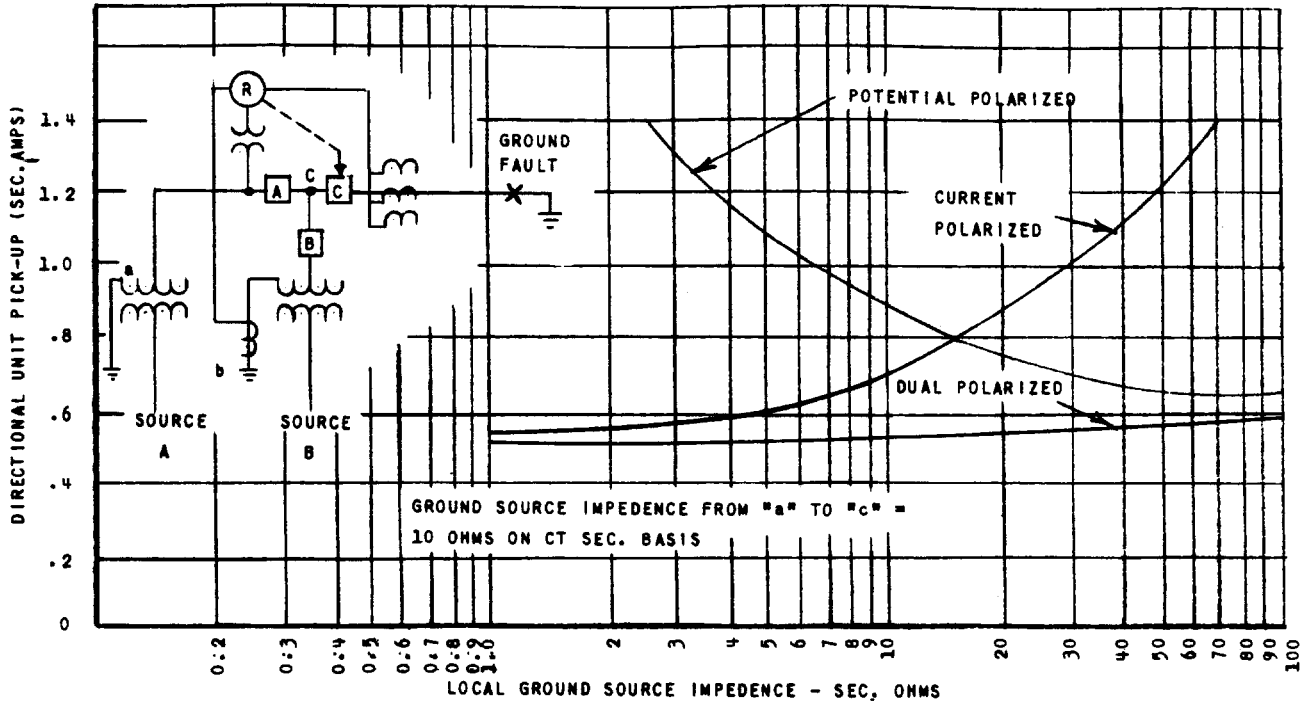

Fig. 7 Type JBCG Directional Unit Pickup For Various Values Of Ground Fault Impedance With Current, Potential, Or Dual Polarization

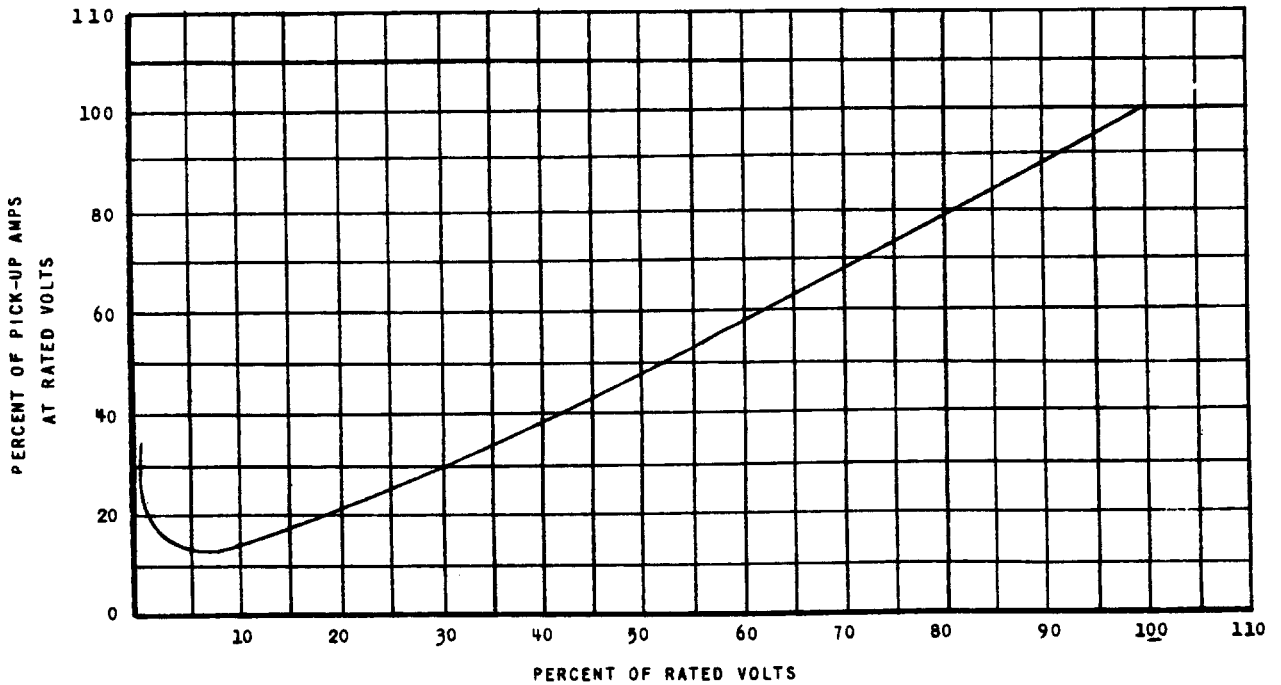

Fig. 8 Typical Directional Unit Pick-up Characteristics Of The Type JBCV Relay With Balanced Voltages And At Maximum Torque Angle



TABLE I  
JBC-JBCG-JBCV RELAYS-INVERSE TIME CHARACTERISTIC

Relay	Functions on	Overcurrent Unit Contacts (Time & Inst.)	Dir. Unit Polarized by	Dir. Unit Phase Angle Obtained by	Approx. Angle of max. torque (cur. with respect to voltage at relay terminals)
JBC51N	Phase faults (May operate on ground faults)	One circuit-closing	Potential	Initial Res. and Capacitor in combination with polarizing coils.	25/50/60 cycles - 45 degree lead
JBC52N		Two circuit-closing			
JBCV51N		One circuit-closing			60 cycles - 45 degree lead.
JBCG51N	Ground Faults	One circuit-closing	Potential and/or current	Series cap. for pot. pol. Floating wdg. & cap. for cur. pol.	60 degree lag for pot. pol. currents approx. in phase for cur. pol.
JBCG52N		Two circuit-closing			

operate on one volt and 4 amperes of proper relative polarity for relays with 4/16 ampere overcurrent units and 115 volt rating, and one volt and 2 amperes for 1.5/6 ampere relays.

The Type JBCV relay is available with directional-unit pickup of either 9 amperes (2/8 ampere range) or 12 amperes (4/16 ampere range) at rated voltage and maximum torque angle. At restraint voltages of less than rating, the operating current is also less; this relationship is shown by the curve in Fig. 8.

The Type JBCG directional unit, when potential polarized, will operate at 3.6 volt-amperes at the maximum torque angle of 60 degrees lag. When current polarized, it will operate at approximately 0.5 ampere, with the two coil sets (operating and polarizing) connected in series. Performance of the unit with simultaneous current and potential polarization is typified by Fig. 7.

Time curves for the directional unit of the Type JBC relay are shown in Figs. 9 and 10. In each case, the polarizing voltage is dropped from 115 volts to the value shown on the curve. The polarizing circuit of these relays incorporates the so-called "memory-action" feature which accounts for proper operation of the unit when the polarizing voltage is dropped to zero. These same curves apply also to the Type JBCV directional unit when the restraint voltage is removed.

Time curves for the directional unit in the Type JBCG relay are shown in Fig. 13 for potential and current polarization.

**TIME OVERCURRENT UNIT**

The unit has been adjusted at the factory to close its contacts at a current within five per cent of the tap plug setting for any time dial position. It will reset at approximately 85 per cent of the closing current on any tap setting. The time curves for this unit are shown in Fig. 11.

**INSTANTANEOUS UNIT**

The time curve for the instantaneous unit of these relays is shown in Fig. 12.

**RATINGS**

Table II gives the ranges available for the time overcurrent units of the various relays, as well as the continuous and short-time ratings of these units. Since the instantaneous unit coils are also in series with the time overcurrent unit, the ratings of the instantaneous unit should also be considered in determining the rating of the entire operating circuit. Table III shows available ranges of the instantaneous unit as well as the ratings for the various ranges.

TABLE II  
RATINGS OF OPERATING COILS  
TIME OVERCURRENT UNITS

Relay Type	Available Tap Range (Amps)	Tap Ratings In Amps	1 Sec. Rating	Contin. Rating *
JBC	1.5/6	1.5, 2, 2.5, 3, 4, 5, 6	200	5
	4/16	4, 5, 6, 8, 10, 12, 16	220	10
JBCV	2/8	2, 2.5, 3, 4, 5, 6, 8	200	5
	4/16	4, 5, 6, 8, 10, 12, 16	220	10
JBCG	0.5/2	0.5, 0.6, 0.8, 1.0, 1.2, 1.5, 2	100	1.5
	1.5/6	1.5, 2, 2.5, 3, 4, 5, 6	200	5

\*Applies to all taps up to and including this value. For taps above this continuous rating is the same as tap value.

Short time rating of potential polarized coil for G relay is 360 volts for 10 seconds.

GEH-1767 Directional Overcurrent Relays Types JBC, JBCG, And JBCV

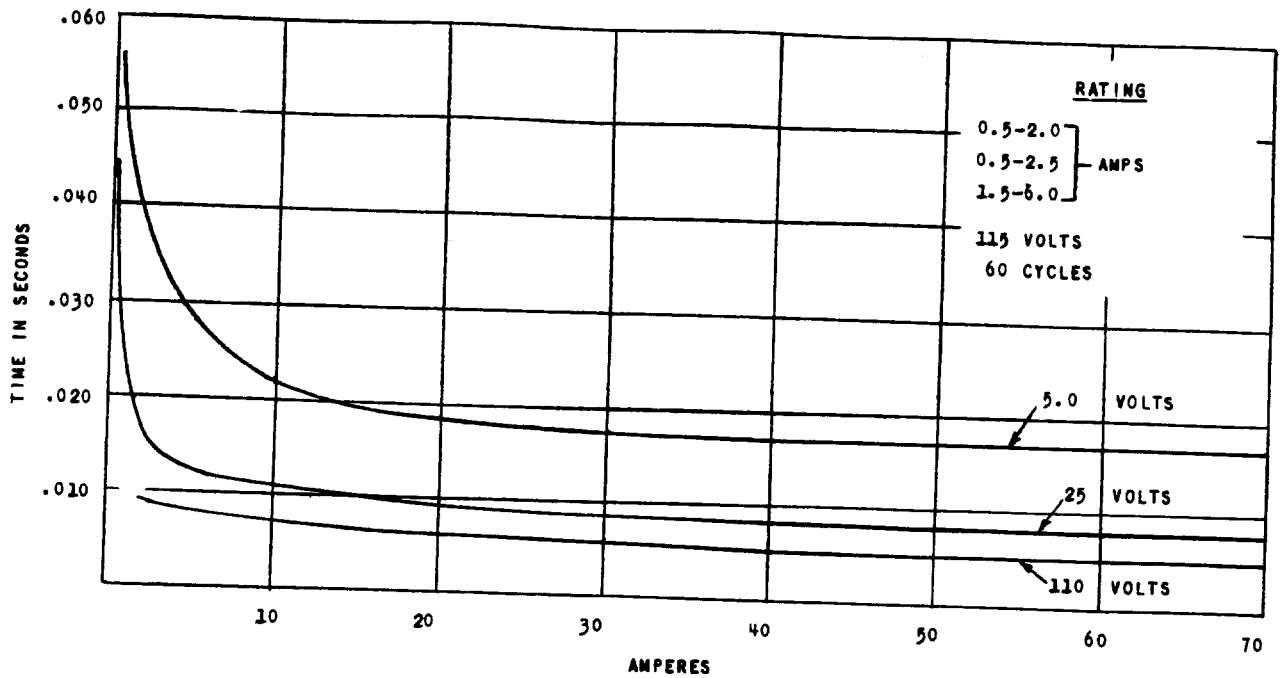

Fig. 9 Time Curves For Directional Unit Of Type JBC Relays (1.5/6 Ampere Range) For Voltage Applied In Phase With Current

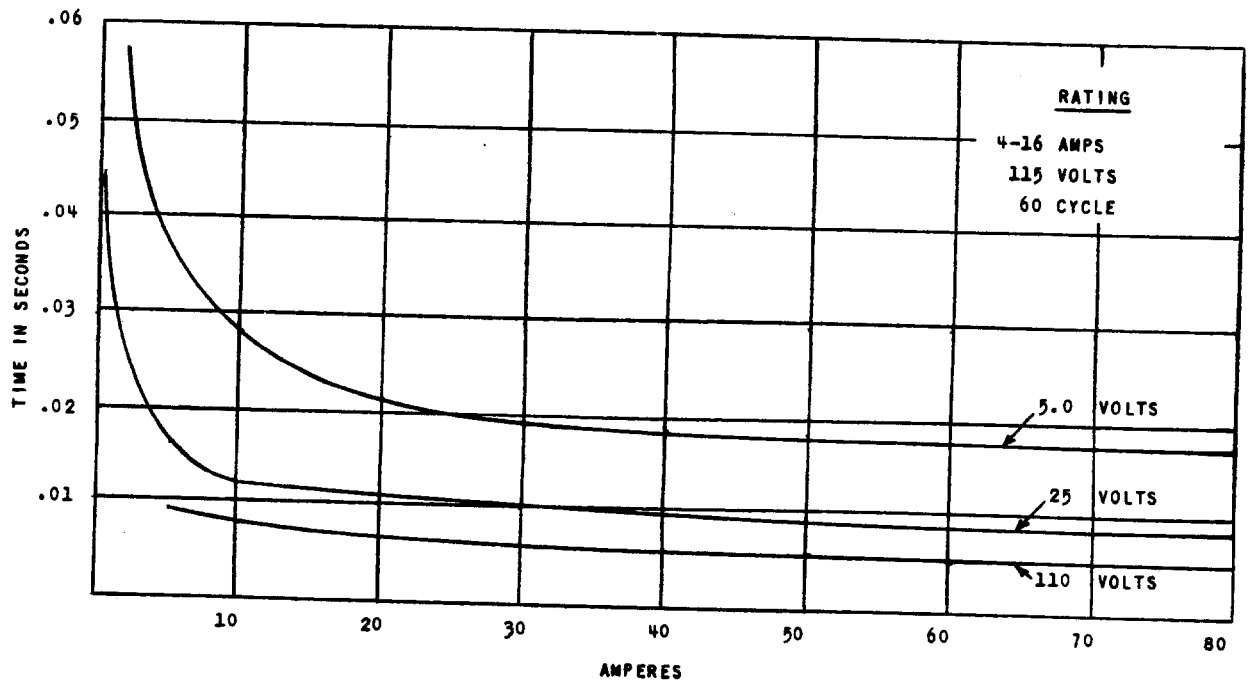

Fig. 10 Time Curves For Directional Unit Of Type JBC Relays (4/16 Ampere Range) For Voltage Applied In Phase With Current

TYPICAL TIME-CURRENT CURVE  
INVERSE TIME CHARACTERISTICS  
TYPE IAC51A CYCLES 60

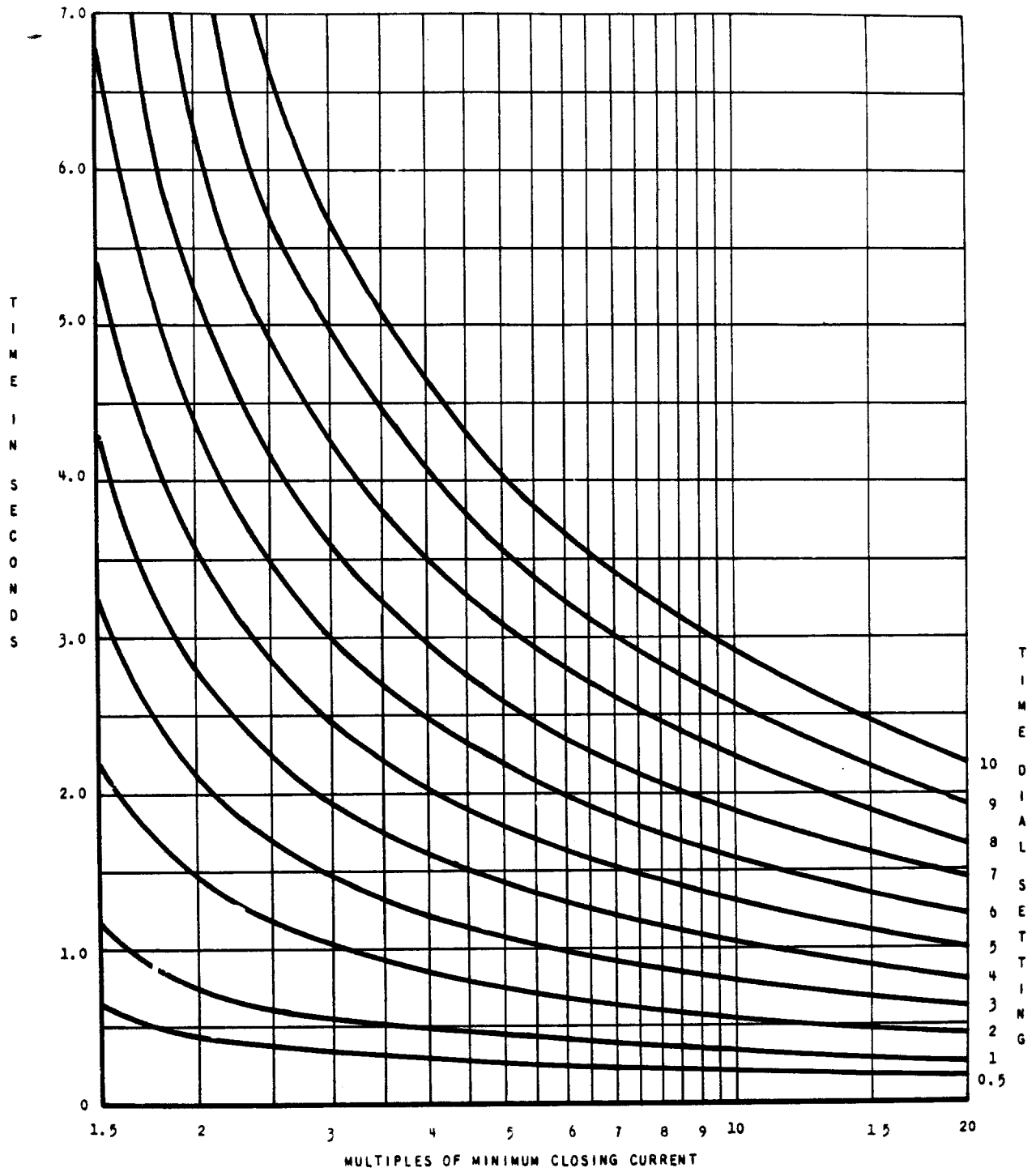

Fig. II Time-Current Curves For The Inverse Time Overcurrent Unit

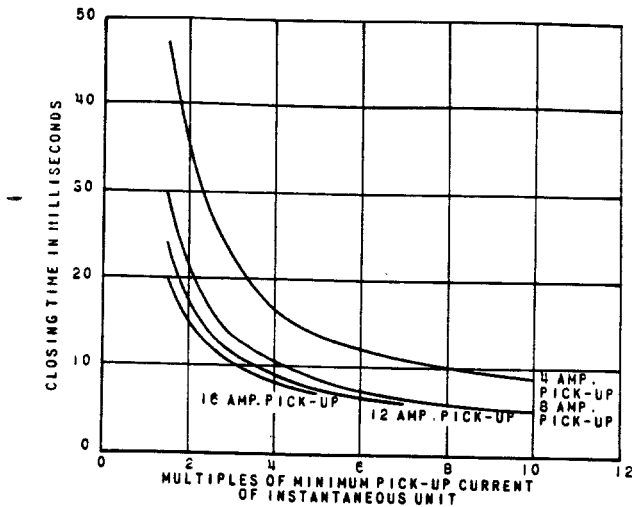

Fig. 12 Typical Time-Current Curves Of The Instantaneous Unit Of Types JBC, JBCG, And JBCV Relays

TABLE III  
RATINGS OF OPERATING COILS  
INSTANTANEOUS OVERCURRENT UNITS

Available Range Amps	1 - Second Rating (Amps)
2-8	150
4-16	150
10-40	220
20-80	220
40-160	220

TABLE IV  
SEAL-IN UNIT RATINGS

	2 Amp Tap	0.2 Amp Tap
Carry Tripping Duty	30 Amps	5 Amps
Carry Continuously	4 Amps	0.4 Amps
D-C Resistance	0.13 Ohms	7 Ohms
Impedance (60 cyc.)	0.53 Ohms	52 Ohms

CONTACTS

The current-closing rating of the induction unit contacts is 30 amperes for voltages not exceeding 250 volts. The current-carrying rating is limited by the tap rating of the seal-in unit.

SEAL-IN UNIT

The rating and impedance of the seal-in unit for the 0.2 and 2 ampere taps are given in Table IV. The tap setting used will depend on the current drawn by the trip coil. The current ratings are either a-c or d-c.

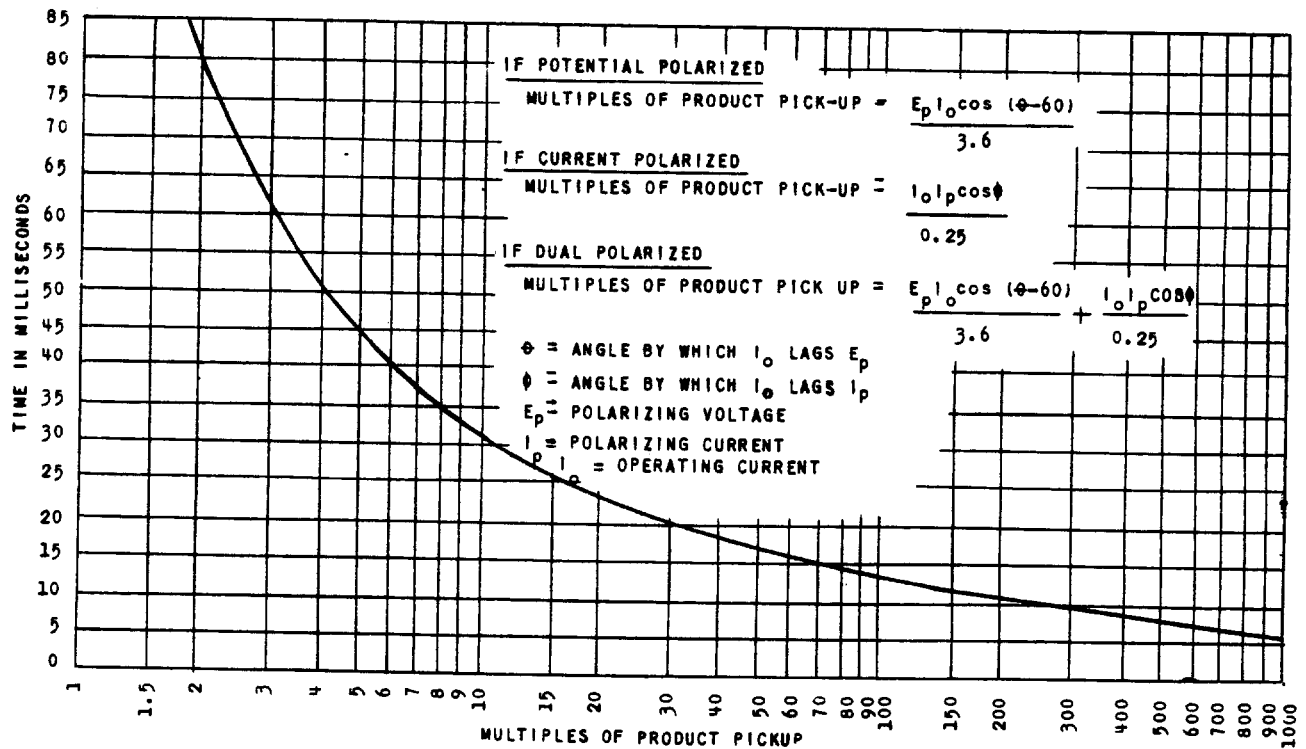

Fig. 13 Time Curves For Directional Unit Of Type JBCG Relays, Current Or Potential Polarized

The 0.2-ampere tap is for use with trip coils which operate on currents ranging from 0.2 up to 2.0 amperes at the minimum control voltage. If this tap is used with trip coils requiring more than 2 amperes, there is a possibility that the resistance of 7 ohms will reduce the current to so low a value that the breaker will not be tripped.

The 2-ampere tap should be used with trip coils that take 2 amperes or more at minimum control voltage, provided the current does not exceed 30 amperes at maximum control voltage. If the tripping current exceeds 30 amperes, the con-

nections should be arranged so that the induction-unit contacts operate an auxiliary relay which in turn energizes the trip coil or coils. On such an application, it may be necessary to connect a loading resistor in parallel with the auxiliary relay coil so enough current will be drawn to operate the target seal-in unit.

**BURDENS**

Tables V, VI and VII give the burdens for the current and potential circuits of both phase and ground relays.

TABLE V  
BURDENS OF OVERCURRENT UNITS (TIME & INSTANTANEOUS)  
FOR ALL JB, JBCG AND JBCV INVERSE TIME RELAYS

Range		Burdens at Min. Pickup of Time Unit					Burdens in ohms Impedance at:		Volt Amperes at 5 Amperes (calculated from burden at Min. P.U.)
Time	Inst.	Eff. Res. (Ohms)	Reactance (Ohms)	Impedance (Ohms) (A)	P. F.	Volt-Amp. (B)	3 x Pickup	10 x Pickup	
0.5/2	All Ranges	7.9	19.7	21.1	0.37	5.3	12.6	7.3	530 (C)
1.5/6	2-8	1.0	2.7	2.9	0.35	6.5	1.7	1.0	73 (C)
1.5/6	4-16 10-40 20-8	0.96	2.6	2.8	0.34	6.3	1.7	0.97	70 (C)
2/8	2-8	0.48	0.92	1.1	0.43	4.4	0.67	0.40	28
2/8	4-16 10-40 20-80	0.40	0.88	0.97	0.41	3.9	0.58	0.34	25
4/16	2-8	0.23	0.41	0.47	0.49	7.5	0.28	0.16	12
4/16	4-16	0.18	0.38	0.42	0.42	6.7	0.25	0.15	10.5
4/16	10-40 20-80	0.15	0.37	0.40	0.38	6.1	0.24	0.14	10

**NOTE A** The impedance values given are those for the minimum tap of each relay. The impedance for other taps, at pick-up current (tap rating), varies inversely approximately as the square of the current rating. Example: for the Type JBC51N relay, 4/16 ampere, the impedance of the 4 ampere tap is 0.42 ohms. The impedance of the 6 ampere tap, at 6 amperes, is approximately  $(4/6)^2 \times 0.42 = 0.19$  ohms.

**NOTE B** Some companies list relay burdens only as the volt-ampere input to operate at minimum pickup. This column is included so a direct comparison can be made. It should not be used in calculating volt-ampere burdens in a CT secondary circuit, since the burden at 5 amperes is used for this purpose.

**NOTE C** These relays are ordinarily used in the residual circuit of current transformers for ground-fault protection. The burden is, therefore, only imposed for the duration of a ground fault and need be considered only for this brief period.

**TABLE VI**  
**BURDENS OF DIRECTIONAL UNIT**  
**CURRENT COILS AT 5 AMPERES**

Relay	Oper. Range	Impedance	Volt-Amperes	P.F.
JBC51N	1.5/6	0.46	12.0	0.52
JBC52N	4/16	0.13	3.3	0.40
JBCG51N	0.5/2	0.46	12.0	0.52 (O)
JBCG52N	0.5/2	0.35	8.8	0.95 (P)
JBCG52N	1.5/6	0.46	12.0	0.52 (O)
JBCG52N	1.5/6	0.35	8.8	0.95 (P)
JBCV51N	2/8	0.12	3.0	0.52
JBCV51N	4/16	0.03	0.88	0.40

(O) Operating Coil Burden

(P) Current polarizing coil burden.

**TABLE VII**  
**BURDEN OF POTENTIAL COILS**  
**(AT 120 VOLTS 60 CYCLES)**

Relay	Watts	Volt-Amperes	P.F.	See note
JBC51N	9.35	10	0.89	
JBC52N				
JBCG51N	15.4	19.6	0.78	(F)
JBCG52N				
JBCV51N	14.1	15.2	0.93	(G)
JBCV51N	3.9	5.9	0.66	(H)

(F) Capacitive burden of potential polarizing circuit calculated at 120 volts.

(G) Polarizing circuit.

(H) Restraint circuit.

## RECEIVING, HANDLING AND STORAGE

These relays, when not included as a part of a control panel will be shipped in cartons designed to protect them against damage. Immediately upon receipt of a relay, examine it for any damage sustained in transit. If injury or damage resulting from rough handling is evident, file a damage claim at once with the transportation company and promptly notify the nearest General Electric Apparatus Sales Office.

Reasonable care should be exercised in un-

packing the relay in order that none of the parts are injured or the adjustments disturbed.

If the relays are not to be installed immediately, they should be stored in their original cartons in a place that is free from moisture, dust and metallic chips. Foreign matter collected on the outside of the case may find its way inside when the cover is removed and cause trouble in the operation of the relay.

## DESCRIPTION

The relays covered by these instructions are identified by model numbers. These models are similar in description with the exceptions of the number of contacts on the instantaneous and time overcurrent units, the angle of maximum torque of the directional unit, and the method of polarizing the directional unit.

### DIRECTIONAL UNIT

The directional unit is of the induction-cylinder construction consisting of a laminated stator having eight poles projecting inward and arranged symmetrically around a stationary central core. The cup-like aluminum induction rotor is free to operate in the annular air gap between the poles and the core. The poles are fitted with current operating coils and with potential or current-polarizing coils.

The principle by which torque is developed is the same as that of an induction disk relay with a wattmetric element, although in arrangement of parts the unit is more like a split-phase induction motor. The induction-cylinder construction provides higher torque and lower rotor inertia than the induction-disk construction, resulting in a faster and more sensitive relay.

### INSTANTANEOUS OVERCURRENT UNIT

This unit is similar in construction to the

directional unit described above, differing only in coil turns and connections. The four corner coils consist of two windings, an inner winding consisting of a large number of turns of fine wire, and an outer winding having a few turns of heavy wire. The outer windings of the corner coils, together with the four side coils, are all connected in series with the operating coil of the time overcurrent unit. The inner windings of the corner coils are all connected in series, and in turn are connected in series with a capacitor and a contact of the directional unit. This circuit thus controls the torque of the instantaneous overcurrent unit. When the directional unit contacts are open, the instantaneous unit will develop no torque. When the directional unit contacts are closed, the instantaneous unit will develop torque in proportion to the square of the current.

### TIME OVERCURRENT UNIT

The inverse time overcurrent unit in these relays is similar to the standard Type IAC51 relay except that it has wound shading coils in place of the punched shading rings. The disk is actuated by a current operating coil assembled on a laminated U-shaped magnet. The disk shaft carries the moving contact which completes the alarm or trip circuit when it touches the stationary contact or contacts. The shaft is restrained by a spiral spring to

give the proper contact-closing current, and its motion is retarded by permanent magnets acting on the disk to produce the desired time characteristic. The variable retarding force resulting from the gradient of the spiral spring is compensated for by the spiral shape of the induction disk, which results in increased driving force as the spring winds up.

The wound shading coils on the U-shaped magnet acts to produce a split-phase field which in turn develops torque on the operating disk. The shading coil leads are connected to an internally mounted step-up transformer, the secondary of which is connected to the directional contacts. When the directional unit contacts are closed, the overcurrent unit is operative, and when they are open, it resets and will not close its contacts even though the current exceeds 20 times pickup value. The overcurrent unit thus will only operate when power flows in the desired direction for tripping. This method of obtaining directional discrimination is known as "Directional Control".

### SEAL-IN UNIT

The seal-in units for both the time-overcurrent and instantaneous-overcurrent contacts are mounted on the middle units, as indicated in Fig. 15.

The left seal-in unit operates in conjunction with the time-overcurrent unit contacts and hence is labeled "T". Its coil is in series and its contacts in parallel with the main contacts of the time-overcurrent unit so that when the main contacts close, the seal-in unit will pick up and seal-in around the main contact.

The right seal-in unit, labeled "I" operates in conjunction with the instantaneous overcurrent unit. Its coil is in series with the instantaneous-unit contact and a contact of the directional unit, and its contact is connected to seal-in around these two contacts when the unit operates.

Both seal-in units are equipped with targets which are raised into view when the unit operates. These targets latch and remain exposed until manually released by means of the button projecting below the lower-left corner of the cover.

### CONTACTS

The contacts, Fig. 14, are especially constructed to suppress bouncing. The stationary contact (G) is mounted on a flat spiral spring (F) backed up by a thin diaphragm (C). These are both mounted in a slightly inclined tube (A). A stainless steel ball (B) is placed in the tube before the diaphragm is assembled. When the moving contact hits the stationary contact, the energy of the former is imparted to the latter and thence to the ball, which is free to roll up the inclined tube. Thus, the moving contact comes to rest with substantially no rebound or vibration. To change the stationary contact mounting spring, remove the contact barrel and sleeve as a complete unit after loosening the screw at the front of the contact block. Unscrew the cap (E). The contact and its flat spiral mounting spring may then be removed.

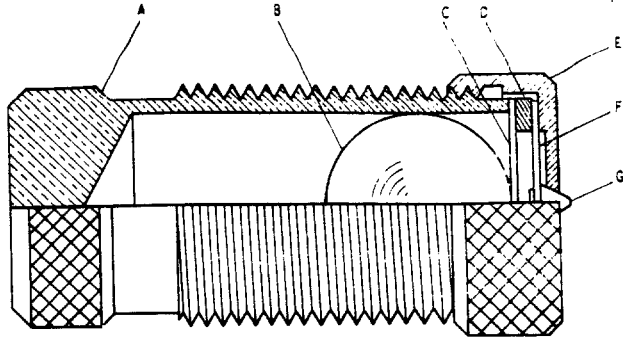

Fig. 14 Contact Assembly For The Directional And The Instantaneous Overcurrent Units

### CASE

The case is suitable for either surface or semiflush panel mounting and an assortment of hardware is provided for either mounting. The cover attaches to the case and also carries the reset mechanism when one is required. Each cover screw has provision for a sealing wire.

The case has studs or screw connections at both ends or at the bottom only for the external connections. The electrical connections between the relay units and the case studs are made through spring backed contact fingers mounted in stationary molded inner and outer blocks between which nests a removable connecting plug which completes the circuits. The outer blocks, attached to the case, have the studs for the external connections, and the inner blocks have the terminals for the internal connections.

The relay mechanism is mounted in a steel framework called the cradle and is a complete unit with all leads being terminated at the inner block. This cradle is held firmly in the case with a latch at the top and the bottom and by a guide pin at the back of the case. The cases and cradles are so constructed that the relay cannot be inserted in the case upside down. The connecting plug, besides making the electrical connections between the respective blocks of the cradle and case, also locks the latch in place. The cover, which is fastened to the case by thumbscrews, holds the connecting plug in place.

To draw out the relay unit the cover is first removed, and the plug drawn out. Shorting bars are provided in the case to short the current transformer circuits. The latches are then released, and the relay unit can be easily drawn out. To replace the relay unit, the reverse order is followed.

A separate testing plug can be inserted in place of the connecting plug to test the relay in place on the panel either from its own source of current and voltage, or from other sources. Or, the relay unit can be drawn out and replaced by another which has been tested in the laboratory.

GEH-1767 Directional Overcurrent Relays Types JBC, JBCG, And JBCV

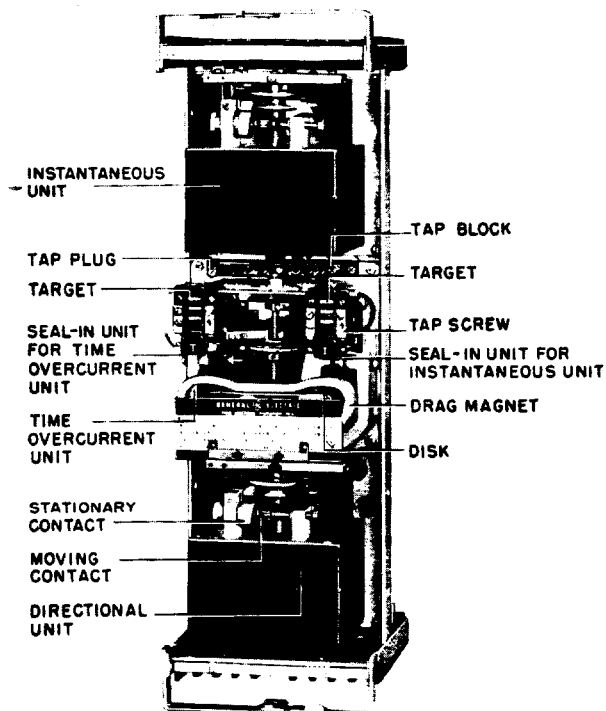

Fig. 15 Type JBCV5IN Relay-Unit In Cradle (Front View)

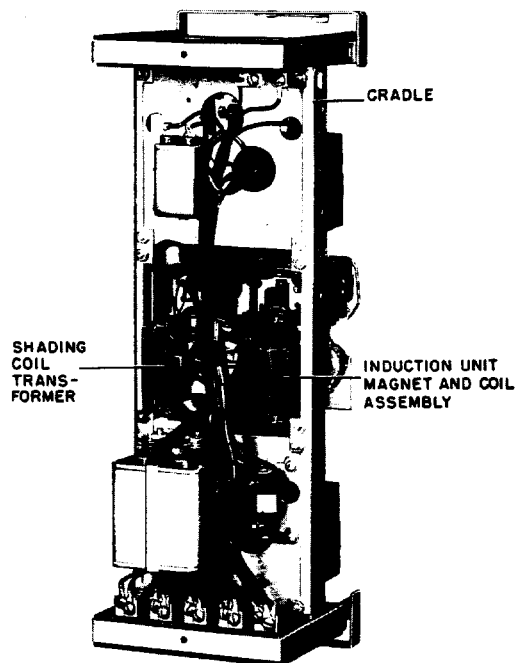

Fig. 16 Type JBCV5IN Relay-Unit In Cradle (Rear View)

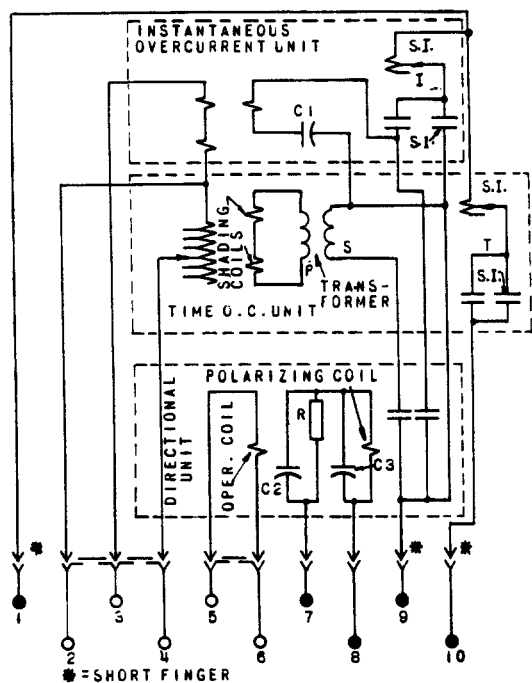
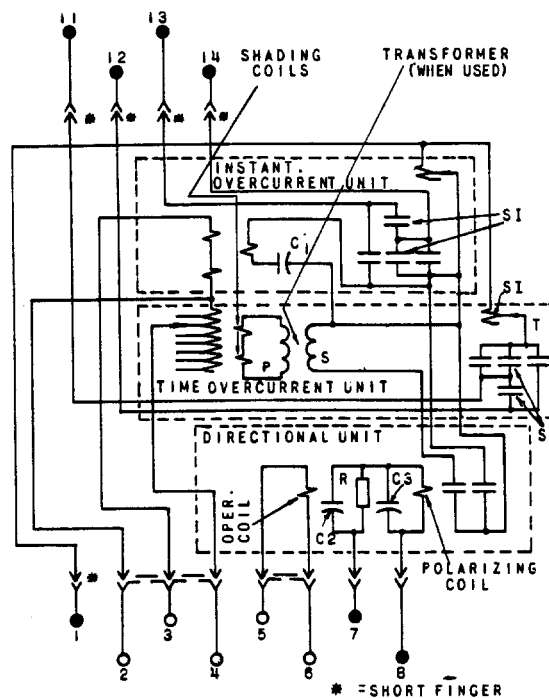

Fig. 17 Internal Connections For The Type JBC5IN Relay (Front View)



\* Fig. 18 Internal Connections For The Type JBC52N Relay (Front View)

\* Changed since last revision.



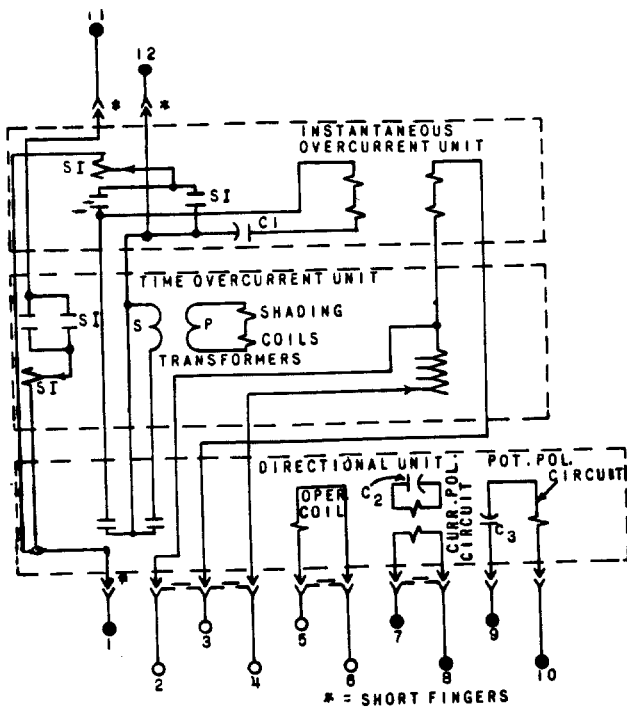
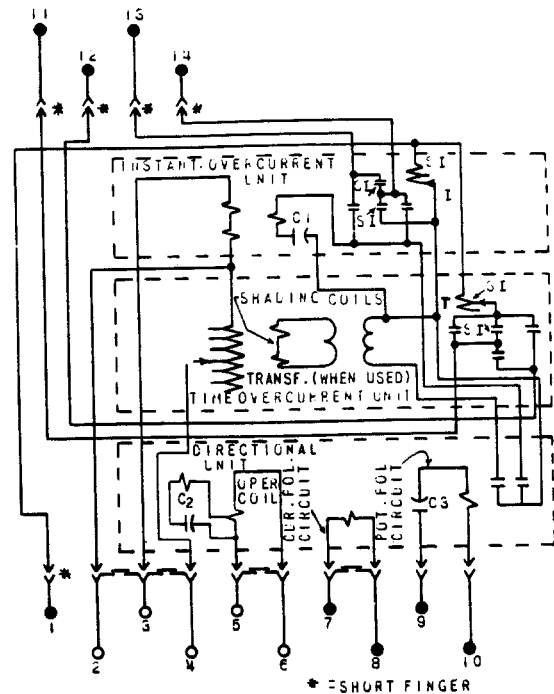

Fig. 19 Internal Connections For The Type JBC651M Relay (Front View)



\* Fig. 20 Internal Connections For The Type JBC652M Relay (Front View)

## INSTALLATION

### LOCATION

The location should be clean and dry, free from dust and excessive vibration, and well lighted to facilitate inspection and testing.

### MOUNTING

The relay should be mounted on a vertical surface. The outline and panel drilling diagrams are shown in Figs. 26 and 27.

### CONNECTIONS

The internal connection diagrams for the various relays are shown in Figs. 17 to 21. Typical wiring diagrams are shown in Figs. 2 to 5.

One of the mounting studs or screws should be permanently grounded by a conductor not less than No. 12 B&S gage copper wire or its equivalent.

### INSPECTION

At the time of installation, the relay should be inspected for tarnished contacts, loose screws, or other imperfections. If any trouble is found, it should be corrected in the manner described under MAINTENANCE.

### OPERATION

Before the relay is put into service, it should be given a partial check to determine that factory adjustments have not been disturbed. The time dial will be set at zero before the relay leaves the factory. It is necessary to change this setting order to open the overcurrent contacts.

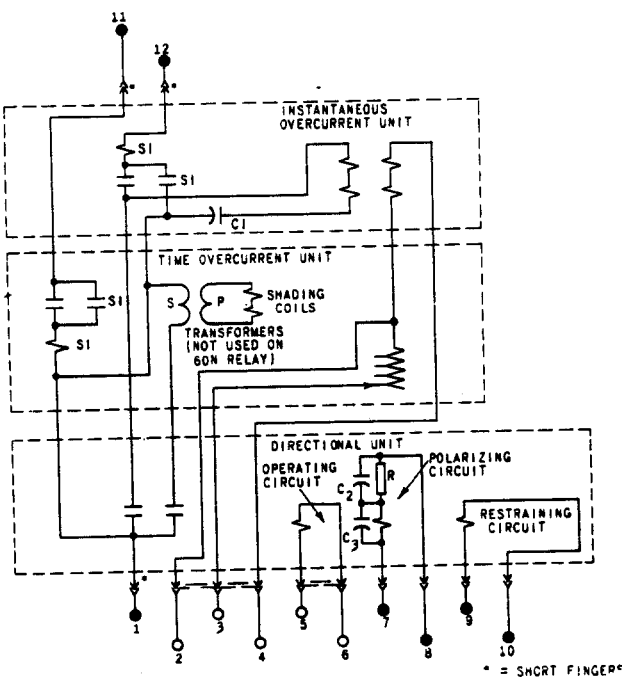

Fig. 21 Internal Connections For The Type JBCV51M Relay (Front View)

\* Changed since last revision.

## ADJUSTMENTS

Adjustments which are frequently made following installation are listed below. Other adjustments which are made at the factory, and which should be subsequently changed only if they are disturbed, are listed under MAINTENANCE.

### TIME OVERCURRENT UNIT

#### TARGET AND SEAL-IN UNIT (MARKED "T")

When used with trip coils operating on currents ranging from 0.2 to 2.0 amperes at minimum control voltage, the target and seal-in tap plug should be set in the 0.2-ampere tap. When the trip coil current ranges from 2 to 30 amperes at minimum control voltage, the tap plug should be placed in the 2.0-ampere tap.

The seal-in unit tap plug is the screw holding the right-hand stationary contact of the seal-in unit. To change the tap setting, first remove the connecting plug. Then, take a screw from the left-hand stationary contact, and place it in the desired tap. Next remove the screw from the other tap, and place it back in the left-hand contact. This procedure is necessary to prevent the right-hand stationary contact from getting out of adjustment. If tap plugs are left in both taps, the pickup will be less than 2.0 amperes on d-c but the seal-in unit will take longer to close its contacts. On a-c, the unit will not pick up with screws in both taps.

#### CURRENT SETTING

The minimum current at which the overcurrent unit will close its contacts is determined by the position of the plug in the tap block. The tap plate on this block is marked in amperes as shown in Table II.

When the tap setting is changed with the relay in its case, the following sequence must be followed: (1) Remove the connecting plug; this de-energizes the relay and shorts the current transformer secondary winding. (2) Remove the tap screw and place it in the tap marked for the desired pick-up current. (3) Replace the connecting plug.

The least current required to rotate the disk slowly and to close the contacts should be within five per cent of the value, marked on the tap plate, for any tap setting and time dial position. If this adjustment has been disturbed it can be restored by means of the spring adjusting ring, which can be turned by inserting a tool in the notches around the edge. This adjustment can also be used in obtaining a current setting between the fixed tap values. To accomplish this the tap screw should be placed in the tap nearest the desired value and the spring then set to obtain the specific current.

Test connections for making pick-up and time checks on the overcurrent unit are shown in Figs. 22 and 23. Use a source of 115 volts or greater with good wave form and constant frequency. Step-down transformers or phantom loads should not be employed in testing induction relays, since their use may cause a distorted wave form.

### TIME SETTING

The operating time of the overcurrent unit for any given value of current and tap setting is determined by the time dial setting. This operating time is inversely proportional to the current magnitude, as illustrated by the time curves in Fig. 11. Note that the current values on these curves are given as multiples of the tap setting. That is, for a given time dial setting, the time will be the same for 80 amperes on the 8-ampere tap as for 50 amperes on the 5-ampere tap, since in both cases the current is 10 times tap setting.

#### EXAMPLE OF SETTING

A numerical example will illustrate these points. Let it be assumed that consideration of the shape of the time-current curve indicates that the greatest selectivity between the relay in question and other relays will be obtained if the tap setting corresponds to 450 amperes line current and the time dial is set to provide one second delay for a fault giving 3750 amperes line current. Also let it be assumed that the current transformer ratio is 60 to 1.

$$\text{Then } \frac{450}{60} = 7.5 \text{ amperes secondary (use 8-ampere tap)}$$

$$\frac{3750}{60} = 62.5 \text{ amperes secondary, and}$$

$$\frac{62.5}{8} = 7.8 \text{ times current tap setting.}$$

Referring to the time-current curves in Fig. 11 we find that the 7.8 times tap setting will give one-second delay, if the time dial is set at the 3.4 position. It is advisable to check the time setting with an accurate timing device. Slight readjustments in the time dial setting can then be made until the desired setting is obtained.

Further aid in making the proper selection of relay settings can be obtained by consulting the nearest Sales Office of the General Electric Company.

## INSTANTANEOUS OVERCURRENT UNIT

#### TARGET AND SEAL-IN UNIT (MARKED "T")

The target and seal-in unit for the instantaneous overcurrent unit, is mounted on the right-hand side of the time overcurrent unit and is identified by a white "T" engraved on its front. The unit is identical with the target and seal-in for the time overcurrent unit, and the same instructions should be followed in adjusting it.

#### PICKUP SETTING

The pickup of the instantaneous overcurrent unit can be adjusted over a four-to-one range, as indicated in Table III, by varying the tension of the

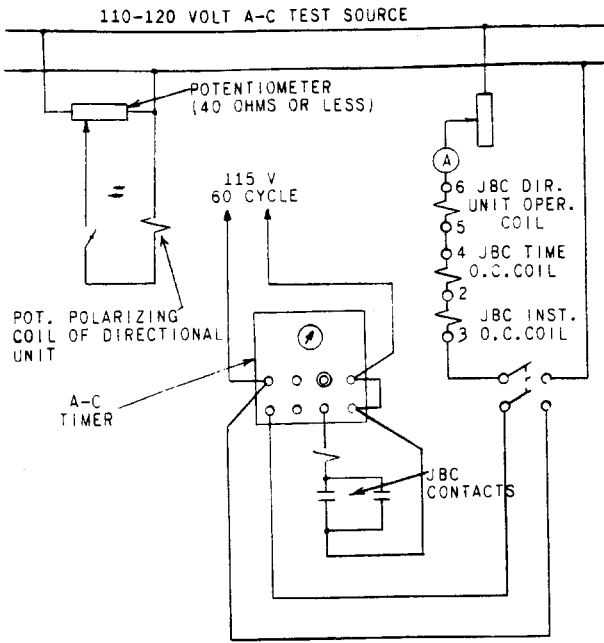

Fig. 22 Test Connections For Checking Pickup And Time Of Potential Polarized Relays

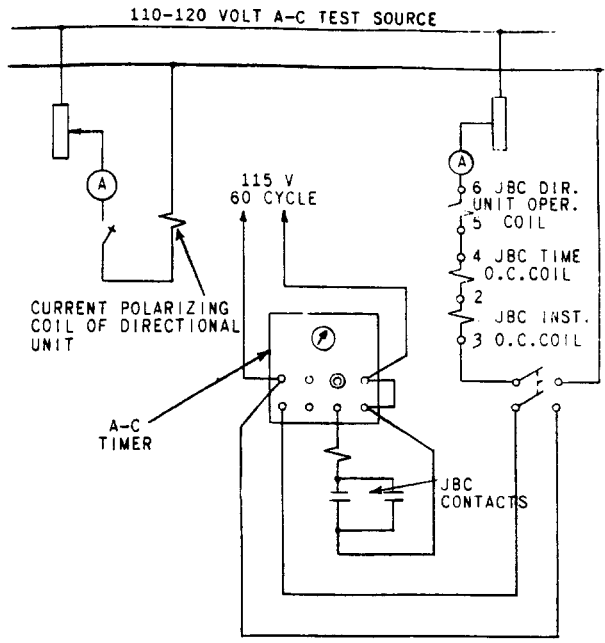

Fig. 23 Test Connections For Checking Pickup And Time Of Current Polarized Relays

spiral control spring. The outside end of this spring is fastened to a post on the adjusting ring above the moving contact, and the ring is in turn clamped in position by a hexagonal-head locking screw. If this screw is loosened, the ring can be shifted to vary the spring tension.

In adjusting pickup, the desired pick-up current should be passed through the coils and the control spring adjusted until the contact just closed. The adjusting ring should then be locked in position and the pick-up current rechecked. Note that the directional-unit contacts must be held closed during this adjustment.

## DIRECTIONAL UNIT

### POLARITY CHECK

The polarity of the directional-unit connections in phase-to-phase fault applications may be verified by observing the direction of contact arm torque when the line is carrying load at unity power factor, or slightly lagging power factor. Note that in most directional overcurrent relay applications, the desired directions are: contact closing for power flow away from the bus, and contact opening for power flow toward the bus.

The polarity of the restraint circuit in Type JBCV relays, is automatically checked when it is connected. With normal load and rated voltage, the restraint circuit should always cause the directional contacts to open regardless of direction of power flow.

The ground relay connections are shown in Figs. 3 and 5. The following tests should be made on the ground element to insure that the currents, or current and voltage, go to the proper relay terminals.

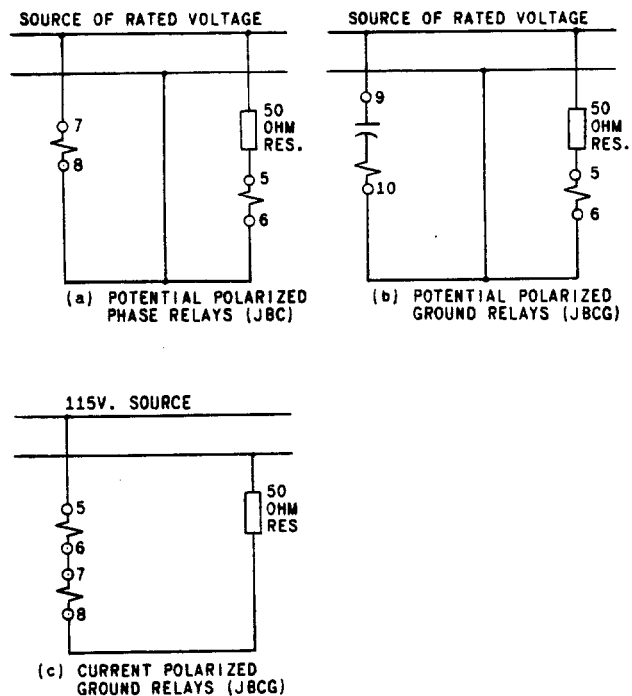

Fig. 24 Connections For Polarity Test Of Types JBC And JBCG Relays

The polarity of the ground directional unit, when it is potential polarized, may be checked by using load currents. The idea is to obtain current from one transformer and voltage from the same phase. The voltage is obtained by removing phase one from the primary of the broken-delta transformer and shorting the phase-one primary winding to ground. Current is obtained by shorting the current transformers in phases two and three and opening their circuits to the relay. This permits the current transformer in phase one to supply the current.

Connect a phase-angle meter to read the angle between the current and voltage supplied to the relay. The relay has maximum torque at 45 degrees lag. With power flowing in the proper direction for operation, the relay should operate for

phase angles within plus or minus 60 degrees of the maximum torque angle.

If the unit is polarized from a current transformer in the power transformer neutral, such a check is not easily made. It is sometimes practical to introduce a single-phase current in one phase of the primary circuits in such a way that current flows through both the transformer neutral current transformer and one of the line current transformers. If this cannot be done, a careful wiring check must suffice.

The polarity of the directional units in phase or ground relays can be checked by means of the circuits shown in Figs. 24 and 25. The connections shown should close the contacts at rated voltage and frequency.

## MAINTENANCE

These relays are adjusted at the factory and it is advisable not to disturb the adjustments. If, for any reason, the adjustments have been disturbed, the following points should be observed in restoring them:

### DIRECTIONAL UNIT

#### TORQUE ADJUSTMENT FOR TYPE JBC51N, JBC52N AND JBCV51N RELAYS

The directional unit in these relays is provided with a notched core which is used to minimize the torque produced on the rotor by current alone in the operating coils with the polarizing circuits, current or potential, de-energized. This adjustment is made at the factory and may be checked as follows:

First, short out the potential polarizing coil circuits and the voltage restraint circuit when it is present. Leave the current polarizing coils open-circuited on ground relays. Adjust the control spring so that the moving contact structure is balanced between the stationary contact and the stop. This can be done by loosening the hexagonal-head locking screw, which clamps the spring adjusting ring in position, and turning the ring to the left until the balance point is reached.

Energize the operating circuit with the current specified below for type and rating, and check that the contact arm does not move. The core should be turned in small steps until a point is reached where there is no "bias" torque from current alone. The core can be turned by loosening the large hexagonal nut on the bottom of the unit and turning the core by means of the slotted bearing screw. This screw should be held securely in position when the nut is retightened.

Type	Current Rating	Test Amps
JBC	1.5/6	30
	4/16	60
JBCV	2/8	30
	4/16	30

Keep in mind that currents of these magnitudes will cause the coils to overheat if left on too long. Therefore, leave the test current on only for short intervals and allow sufficient time between tests for the coils to cool.

After the torque adjustment has been made, the spiral spring should be set to have barely enough tension to swing the moving contact arm against the stop screw when the unit is de-energized. Sufficient tension will be obtained if the adjusting ring is rotated about 1/2 inch from the neutral position in the counterclockwise direction, as measured on the periphery of the ring.

#### CLUTCH ADJUSTMENT

The connections shown in Figs. 24 and 25 for the polarity check can also be used in making the clutch adjustment. The 50 ohm fixed resistor should be replaced with an adjustable resistor capable of providing the current range listed in Table VIII for the relay type and rating in question. A screw, projecting from the side of the movable contact arm, controls the clutch pressure, and consequently, the current value which will cause the clutch to slip. With rated frequency and at rated volts for potential-polarized relays, the clutch should be set to slip at the current values listed in Table VIII. In all cases the current is in phase with the voltage.

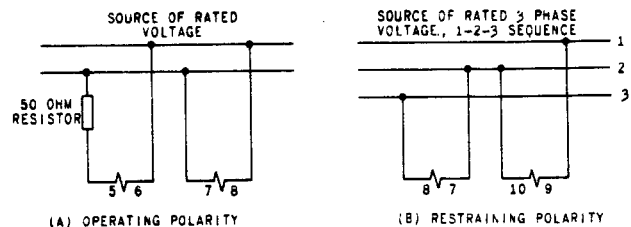

THE CONTACTS OF THE DIRECTIONAL UNIT SHOULD CLOSE WHEN RELAY IS ENERGIZED WITH EITHER OF THE ABOVE CONNECTIONS.

Fig. 25 Connections For Polarity Test Of Type JBCV Relays

TABLE VIII

Relay Type	Polarization	Pick-up Range (Amps)	Amps for clutch to slip
JBC	Potential	4/16	22
		1.5/6	11
		0.5/2	11
JBCG	*current or potential	4/16	12
		1.5/6	7
		0.5/2	7
JBCV	Potential	2/8	6 **
		4/16	8.5 **

\* Make clutch adjustment with unit polarized by one of the two methods only.

\*\* See Text.

On Type JBCV relays the clutch slip is limited to approximately 20 degrees by means of a stop pin in the shaft. It should first be set to slip in the counterclockwise direction at the current values listed in the table with the polarizing circuit energized but with the restraint circuit open. Then check that the clutch will slip to the limit in the clockwise direction with the restraint circuit energized at rated volts and the current circuit open.

**BEARINGS**

The lower jewel bearing should be screwed all the way in until its head engages the end of the threaded core support. The upper bearing should be adjusted to allow about 1/64 inch end play to the shaft.

To check the clearance between the iron core and the inside of the rotor cup, press down on the contact arm near the shaft and thus depress the spring-mounted jewel until the cup strikes the iron. The shaft should move about 1/16 inch.

The lower jewel can be tested for fractures by exploring its surface with a fine needle.

**CUP AND STATOR**

Should it be necessary to remove the cup-type rotor from the directional unit, the following procedure should be followed:

All leads to the unit should first be disconnected and tagged for identification in reconnecting. The unit can then be removed from the cradle with its mounting plate still attached.

The upper of the three flat-head screws holding the unit to the plate should now be removed. On some models, it may be necessary to remove a resistor or capacitor to expose this screw. The four corner screws clamping the unit together, should next be removed, and the entire top structure lifted off. This gives access to the cup assembly and exposes the stator assembly, which should be protected to keep it free from dust and metallic particles until the unit is reassembled.

To remove the shaft and rotor from the contact head assembly, the spring clip at the top of the shaft must be pulled out and the clutch adjusting screw taken out of the side of the molded contact arm. The shaft and cup can now be pulled out of the molding. The rotor must be handled very carefully while it is out of the unit.

**CONTACT ADJUSTMENT**

The contact gap may be adjusted by loosening slightly the screw at the front of the contact block. The screw should be loose enough only to allow the contact barrel to rotate in its sleeve.

The stop screw fastened with a locknut should hold the moving contact arm in a neutral position; i.e., with it pointing directly forward. Then, bring the stationary contact up until it just touches the moving contact by rotating the contact barrel. Next, back it away 2/3 turn to obtain approximately 0.020 inch contact gap. Last, tighten the screw which secures the barrel.

The moving contact may be removed by loosening the screw which secures it to the contact arm and sliding it from under the screw head.

**INSTANTANEOUS OVERCURRENT UNIT**

**TORQUE ADJUSTMENT**

The spiral spring on the contact shaft should have enough tension to return the moving contact arm to the neutral position where it rests against the stop screw, when de-energized. Its tension may be varied by slipping the adjusting ring by first loosening the hexagonal-head locking screw which connects the lead to this lead-in spiral spring. Sufficient tension will be had when this ring is rotated in the counterclockwise direction, about 1/2 inch from the neutral position as measured on the periphery of the ring.

**CLUTCH ADJUSTMENT**

The clutch on the instantaneous overcurrent unit can be adjusted by means of the screw located on the right-hand side of the moving contact arm. If the locknut is loosened and the screw turned in, the current at which the clutch will slip will be increased. The clutch should be adjusted to slip at the current values shown below, with the directional unit contacts held closed.

Inst. Overcurrent Unit Rating	Clutch must not slip at	Clutch must slip at
2-8	12	16
4-16	24	32
*10-40		
*20-80		
*40-160		

\* Tighten clutch as much as possible.

**BEARINGS**

The section BEARINGS described under DIRECTIONAL UNIT, also applies to the bearings of the instantaneous overcurrent unit.

## CUP AND STATOR

The section CUP AND STATOR, described under DIRECTIONAL UNIT, also applies to the cup and stator of the instantaneous overcurrent unit.

## CONTACT ADJUSTMENT

The section CONTACT ADJUSTMENT, described under DIRECTIONAL UNIT, also applies to the contact adjustment for the instantaneous overcurrent unit.

## TIME OVERCURRENT UNIT

### DISK AND BEARINGS

The lower jewel may be tested for cracks by exploring its surface with the point of a fine needle. The jewel should be turned up until the disk is centered in the air gaps, after which it should be locked in this position by the set screw provided for this purpose. The upper bearing pin should next be adjusted so that the disk shaft has about 1/64 inch end play.

### CONTACT ADJUSTMENT

The contacts should have about 1/32 inch wipe. That is, the stationary contact tip should be deflected about 1/32 inch when the disk completes its travel. Wipe is adjusted by turning the screws in the contact brush thereby adjusting the position of the brush relative to the brush stop. The tips should lie in the same vertical plane on two-circuit closing relays.

When the time dial is moved to the position where it holds the contacts just closed, it should

## RENEWAL PARTS

It is recommended that sufficient quantities of renewal parts be carried in stock to enable the prompt replacement of any that are worn, broken, or damaged.

When ordering renewal parts, address the

indicate zero on the time-dial scale. If it does not and the brushes are correctly adjusted, shift the dial by changing the position of the arm attached to the shaft just below the time dial. Loosen the screw clamping the arm to the shaft and turn the arm relative to the shaft until the contacts just make for zero time-dial setting.

## CONTACT CLEANING

For cleaning fine silver contacts, a flexible burnishing tool should be used. This consists of a flexible strip of metal with an etched roughened surface, resembling in effect a superfine file. The polishing action is so delicate that no scratches are left, yet corroded material will be removed rapidly and thoroughly. The flexibility of the tool insures the cleaning of the actual points of contact. Sometimes an ordinary file cannot reach the actual points of contact because of some obstruction from some other part of the relay.

Fine silver contacts should not be cleaned with knives, files, or abrasive paper or cloth. Knives or files may leave scratches which increase arcing and deterioration of the contacts. Abrasive paper or cloth may leave minute particles of insulating abrasive material in the contacts and thus prevent closing.

The burnishing tool described above can be obtained from the factory.

## PERIODIC TESTING

An operation test and inspection of the relay at least once every six months are recommended. Test connections are shown in Figs. 22 and 23.

nearest Sales Office of the General Electric Company, specify quantity required, name of part wanted, and give complete nameplate data, including serial number. If possible, give the General Electric Company requisition number on which the relay was furnished.

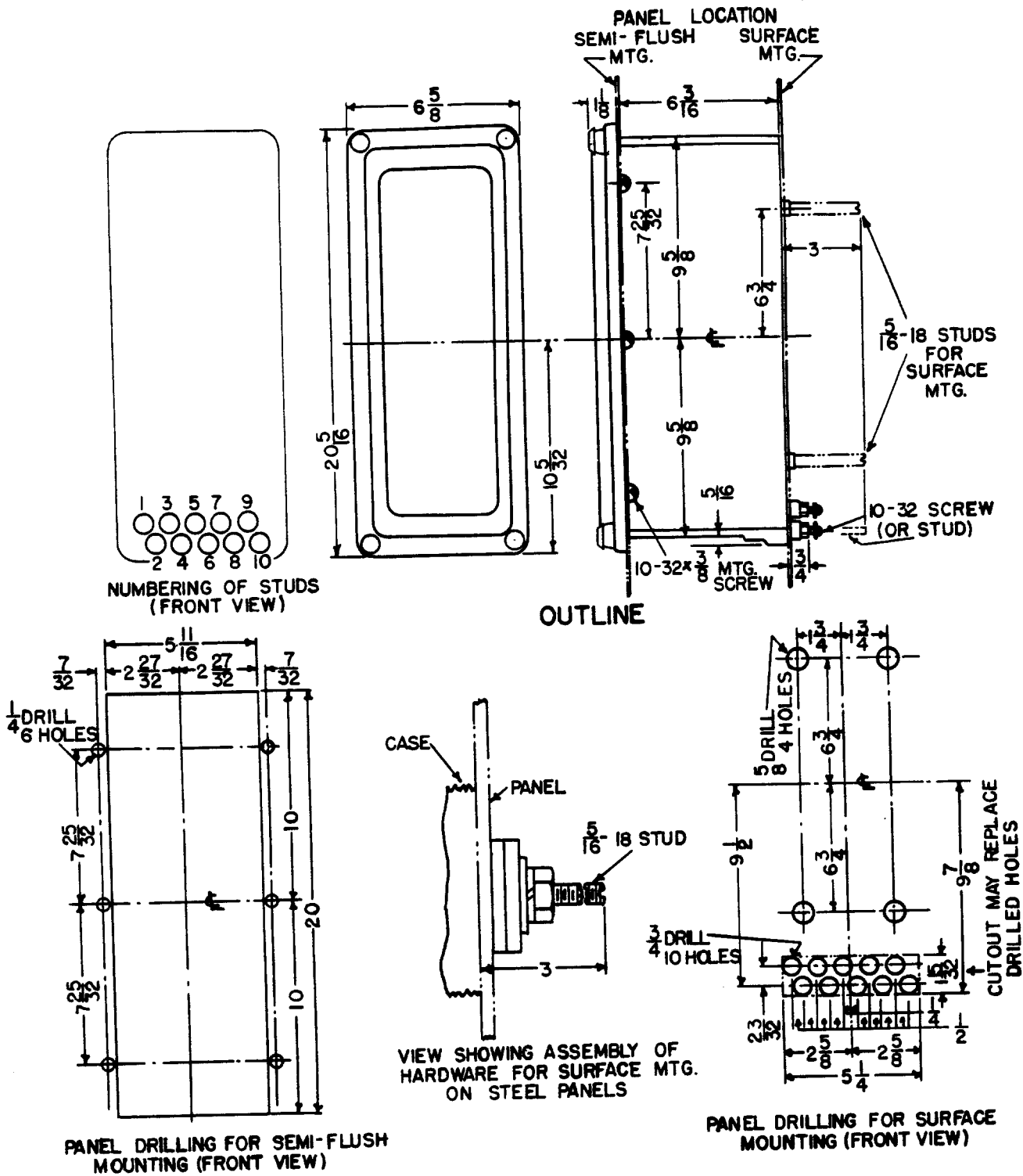

Fig. 26 Outline And Panel Drilling Dimensions For The Type JBC51N Relay

