



# INSTRUCTIONS

---

**PLS1B55C1UL2XB020  
PLS1B55C1UB2XB031**

## **HYBRID SCHEME WITH SINGLE FSK CHANNEL**

### **INTRODUCTION**

These instructions, GEK-100657 together with GEK-90674, constitute the complete instructions for the above relay.

### **DESCRIPTION**

This relay has the following differences from the standard PLS relay described in GEK-90674.

1. Revised DLA and Alarm contact outputs and revised Test Plug PT inputs. See Elementary Drawing 0145D8875.
2. ULM194 module contains a link used to disable the PD1 and ND functions from tripping Zone 1. See Module Diagram 0286A5320 and Logic Diagram 0145D8877.

### **ATTACHMENTS**

- Figure 1 (0286A5320) ULM194 Module Layout
- Figure 2 (0145D8877) Logic Diagram
- Figure 3 (0145D8875) Elementary Diagram

*These instructions do not purport to cover all details or variations in equipment nor provide for every possible contingency to be met in connection with installation, operation or maintenance. Should further information be desired or should particular problems arise which are not covered sufficiently for the purchaser's purposes, the matter should be referred to the General Electric Company. To the extent required the products described herein meet applicable ANSI, IEEE and NEMA standards; but no such assurance is given with respect to local codes and ordinances because they vary greatly.*

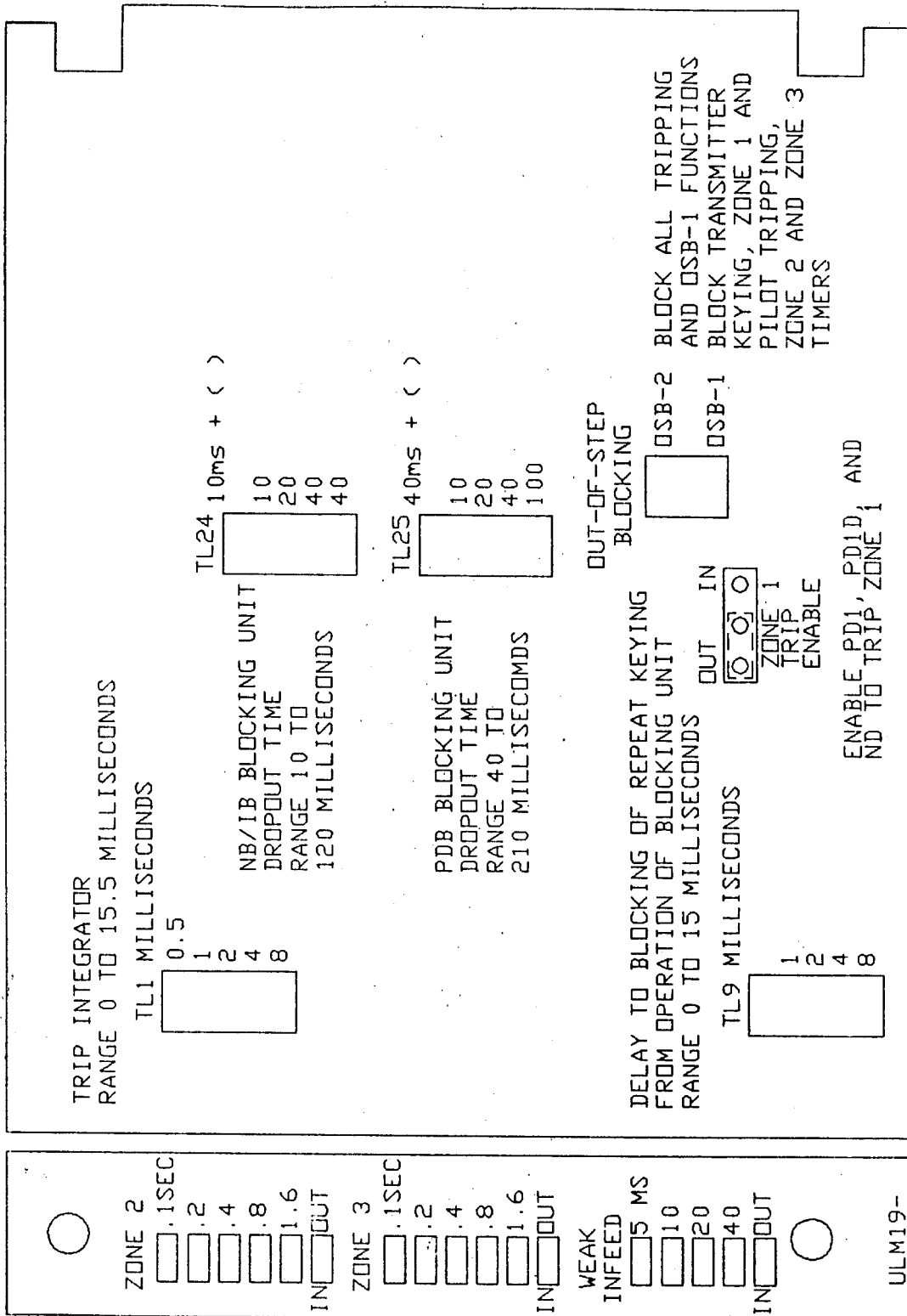
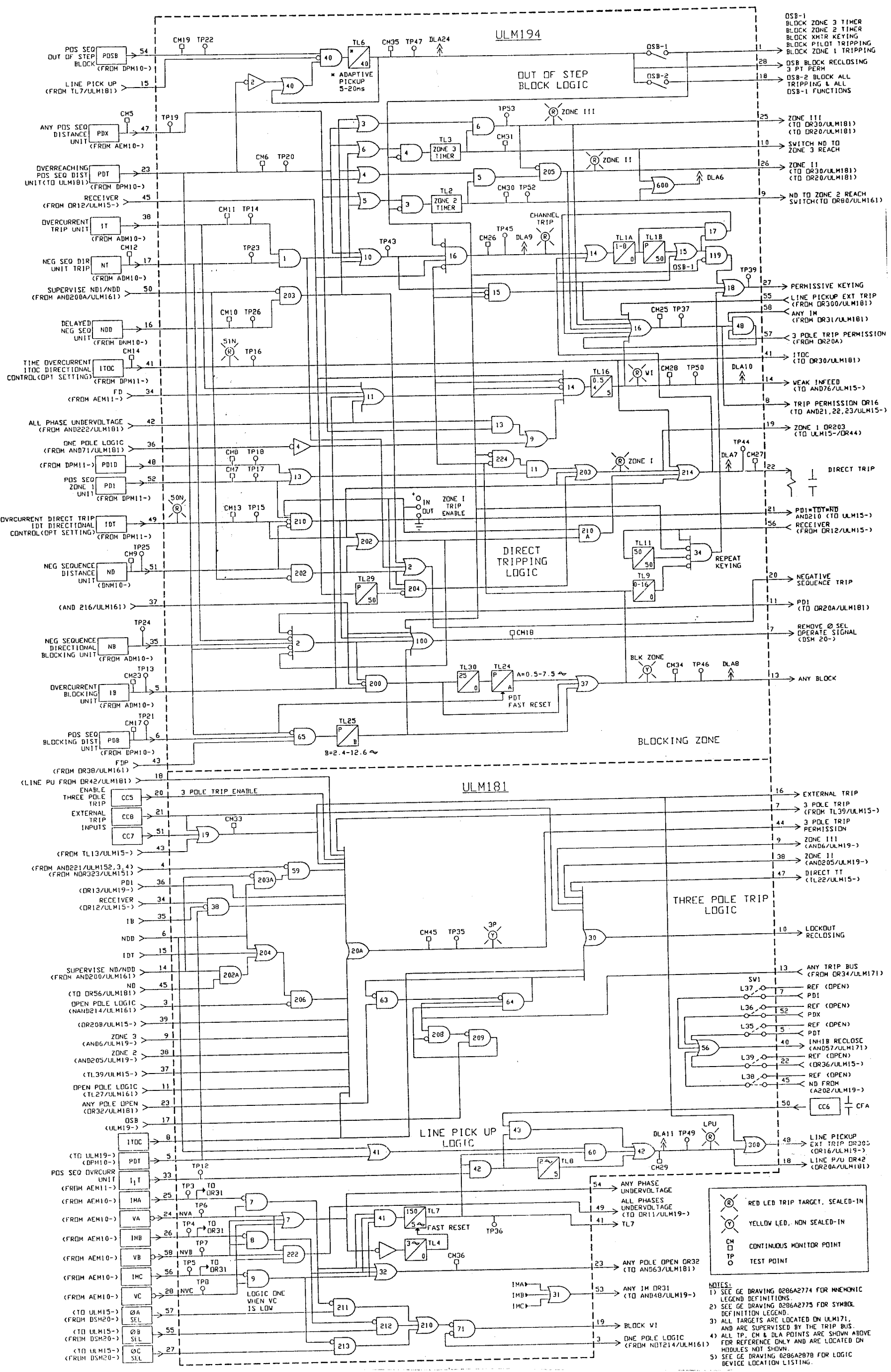

Figure 1 (0286A5320) ULM194 Module Layout

Figure 2 (0145D8877 Sh.1 [3]) Logic Diagram



GEK-100657

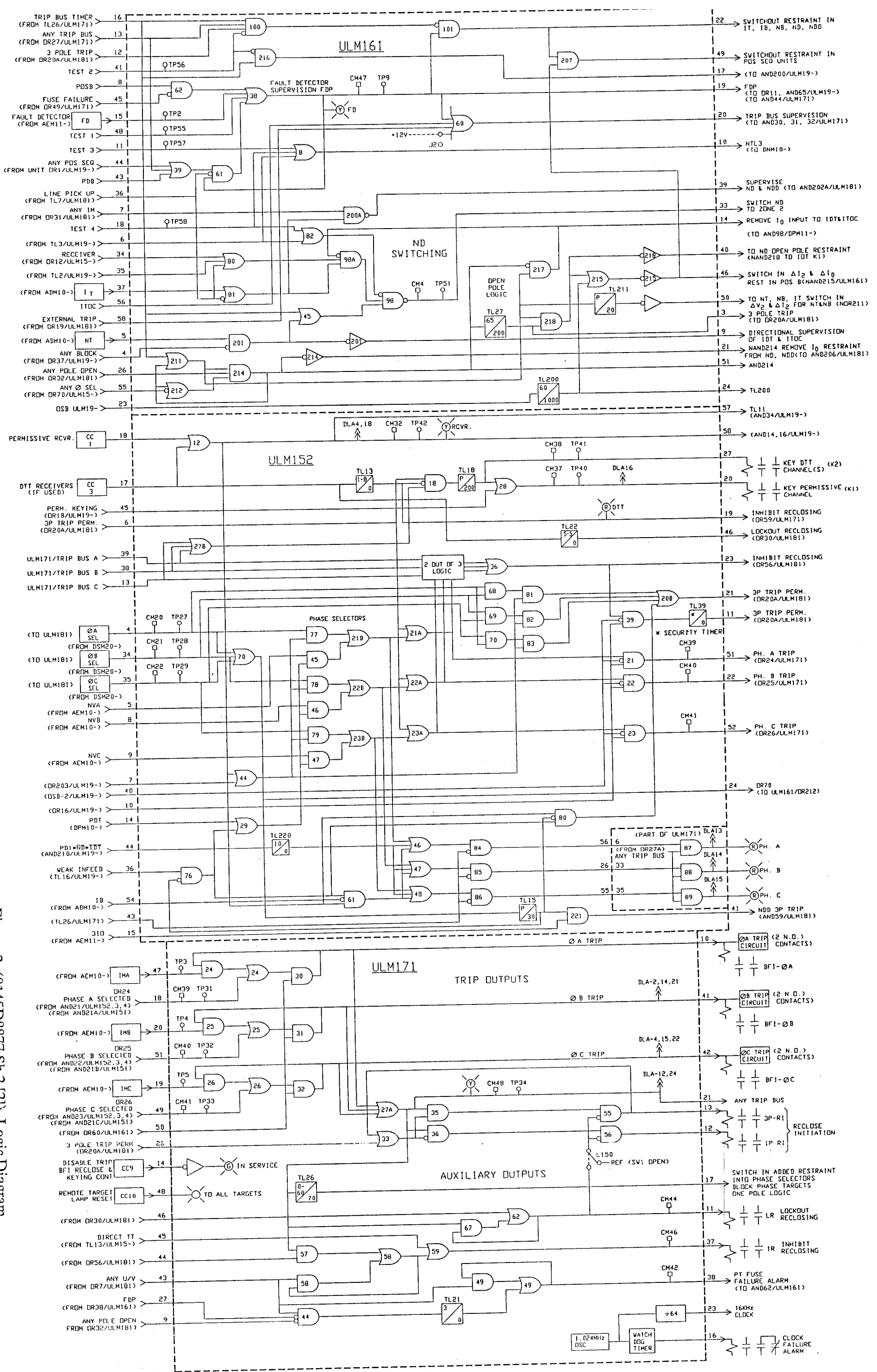

Figure 2 (0145D8877 Sh.2 [2]) Logic Diagram

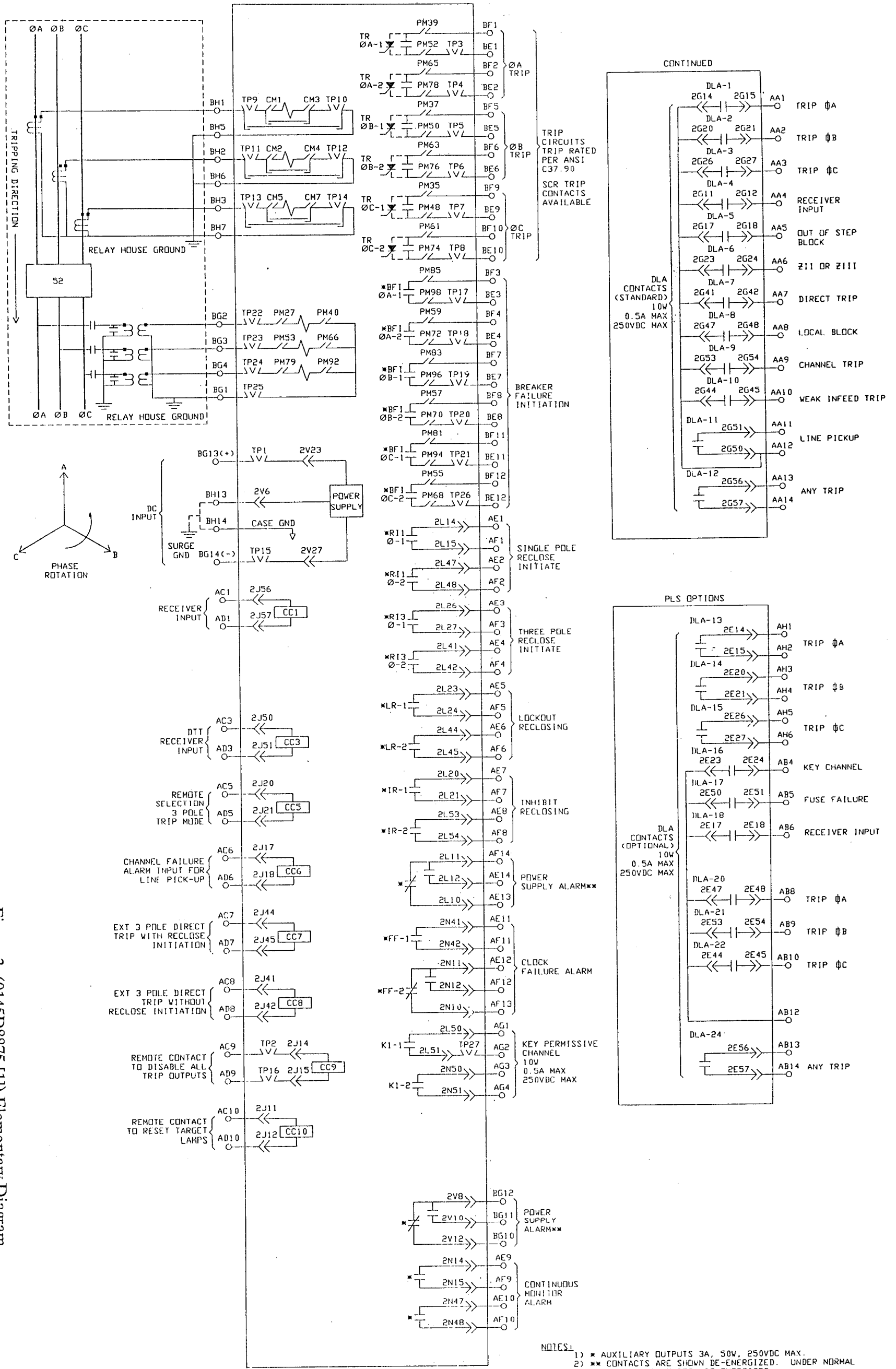

Figure 3 (0145D8875 [1]) Elementary Diagram