



INSTRUCTIONS

GEK-11016B

DRIVER MODULES FOR SILCON VI* SCR DRIVES

OPERATION - ADJUSTMENT - TROUBLE SHOOTING

NON-REVERSING DRIVER
(For Single Conversion Module)

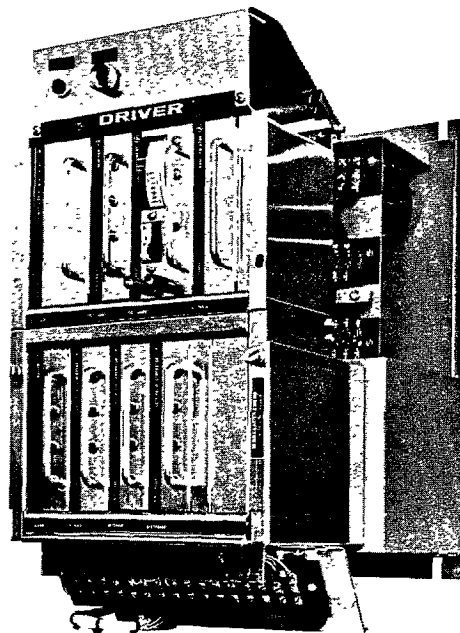

REVERSING DRIVER
(For Back-to-Back Conversion Modules)

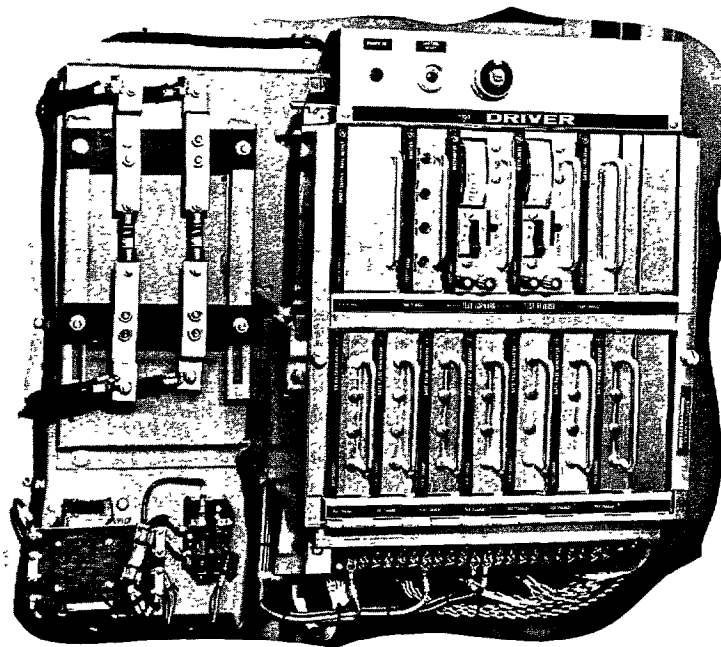

These instructions do not purport to cover all details or variations in equipment nor to provide for every possible contingency to be met in connection with installation, operation or maintenance. Should further information be desired or should particular problems arise which are not covered sufficiently for the purchaser's purposes, the matter should be referred to the General Electric Company.

GENERAL  ELECTRIC

*Trademark of the General Electric Co.

TABLE OF CONTENTS

Page

INTRODUCTION	1
RATINGS AND SPECIFICATIONS	1
PRINCIPLES OF OPERATION	1
Nonreversing Driver.	2
Reversing Driver	3
Synchronizing Transformer Asm.	4
Signal Distribution Asm..	5
OPERATION AND ADJUSTMENTS	5
General Operation	5
Voltage Limit	5
Current Limit	5
Static IOC	5
Bias (Gate Pulse Generator).	5
Zero Adjust (Nonreversing Driver)	6
Dead Band and Zero Adjust (Reversing Driver).	6
TROUBLE SHOOTING.	7
General Approach.	7
Checking for Malfunctions	7
Voltage Check List	10
Voltage Wave Shape Check List	10
APPENDIX	12
Gate Pulse Generator	12
Driver Coordination—Nonreversing	13
Driver Coordination—Reversing	13
Signal Isolator	14
Monitor-Oscillator.	14
Power Supply	15

WARNING

HIGH VOLTAGE. ELECTRIC SHOCK CAN CAUSE SERIOUS OR FATAL INJURY. WHETHER THE AC VOLTAGE SUPPLY IS GROUNDED OR NOT, HIGH VOLTAGES TO GROUND WILL BE PRESENT AT MANY POINTS WITHIN THE SCR DRIVE. EXTREME CARE MUST BE EXERCISED IN THE SELECTION AND USE OF TEST INSTRUMENTS.

OPERATORS SHOULD NOT STAND ON GROUNDED SURFACES OR BE IN CONTACT WITH GROUND WHEN APPLYING TEST INSTRUMENTS TO TEST POINTS. TEST INSTRUMENTS SHOULD NOT HAVE CHASSIS GROUNDED WHILE TESTS ARE BEING MADE. THUS THEIR CHASSIS WILL BE AT A HIGH VOLTAGE WITH RESPECT TO GROUND DURING TESTING. EXTREME CARE SHOULD BE TAKEN WHILE ATTEMPTING TO ADJUST, TROUBLESHOOT OR MAINTAIN ANY DRIVE SYSTEM DESCRIBED HEREIN.

DRIVER MODULES FOR SILCON VI * SCR DRIVES

INTRODUCTION

The driver module is the control building block in the SCR conversion assembly. It accepts a D-C reference signal from the regulator and produces properly synchronized gate pulses to fire the SCR's in the SCR conversion module. It contains protective and logic circuitry to insure the proper operation of the SCR conversion assembly.

There are two basic driver modules, the nonreversing and reversing types. The nonreversing driver has a single direction output whereas the reversing driver has a dual direction output to control back to back connected SCR conversion modules.

The driver module consists of the following individual components:

1. The synchronizing transformer assembly which contains synchronizing and power supply transformers and synchronizing voltage filter circuits.
2. The driver which contains the printed circuit cards which perform the control functions. The printed circuit cards are described individually in the appendix to this instruction.
3. A signal distribution assembly which distributes the driver output and feedback signals to paralleled SCR conversion modules (only furnished on paralleled drives).

RATINGS AND SPECIFICATIONS

1. A-C Input

- (a) Voltage—230 or 460 volts $\pm 10\%$, three phase for synchronizing; 115 volts $\pm 10\%$, single phase for power supply.
- (b) Frequency—60 cps ± 1 cps standard. 50 cps ± 1 cps obtainable with different connection of gate pulse generators.

2. Control Input

- (a) Reference voltage —0 to 10 volts D-C, positive or negative dependent on operating quadrant.

- (b) Voltage feedback —0 to ± 10 volts D-C, one feedback for nonreversing and two feedbacks for reversing drivers.

- (c) Current feedback —0 to +5 volts D-C, one feedback for nonreversing and two feedbacks for reversing drivers.

3. Control Output

- (a) Gate pulse trains—six pulse trains, each 120 degrees wide, spaced 60 degrees apart, each capable of being phase shifted over a range of approximately 150 degrees, for a nonreversing driver. A reversing driver has two sets of these six pulse trains, which are separately applied by means of dead band and lockout circuitry. Each pulse train consists of approximately 60 pulses, each pulse being approximately 25 microseconds wide and 17.5 volts, ± 1 volt in magnitude.
- (b) Power supply— ± 20 volts at 200 milliamps and —20 volts at 200 milliamps power supply for auxiliary regulator usage. Also +20 volts power supply for operation of the pulse amplifying circuitry on the SCR conversion module.
- (c) Fault relay interlock—normally open interlock on a fault relay that is energized during normal operation, for external magnetic fault circuitry usage.

4. Ambient Temperature

- (a) Normal range—10 to 65 degrees centigrade, with unrestricted convection cooling.

PRINCIPLES OF OPERATION

The following theory of operation is a functional description using functional elementary diagrams rather than complete circuitry. This approach is used to simplify explanation and aid in understanding the basic functions rather than the detailed individual circuit operations. A more detailed description of the individual printed circuit card functional operation is contained in the appendix of this instruction.

NONREVERSING DRIVER

The operation of the nonreversing driver is best explained by referring to the elementary diagram contained in the diagram section.

The output of the driver is connected to the SCR conversion module by cable 1CA. This cable collects the six pulse train outputs of the three identical gate pulse generator cards. Each gate pulse generator card, and the oscillator sub-card produces two 120 degree wide pulse trains each full cycle of A-C supply frequency. The oscillator sub-card, mounted on the monitor card determines the individual pulse width and pulse frequency of each pulse train. The gate pulse generator A-C synchronizing voltages, which enter the driver through cable 5CA, determine the phase relationship of the six pulse trains. With correct phase sequence of A-C voltage applied to both the driver module and the SCR conversion module, the six pulse trains will be equally spaced 60 degrees apart, and will fire the SCR's in the correct order to obtain balanced operation (See Figure 20). Each gate pulse generator, simultaneously turns itself on and turns a preceding gate pulse generator off, as shown in Figure 20. This action determines the 120 degree pulse train width.

There are three additional inputs to each gate pulse generator, the peak point input, lockout input and control input. The peak point input sets up the uni-junction transistor circuits in each gate pulse generator card to insure balanced operation over the whole phase shift range. This peak point reference voltage is the same for all gate pulse generators and is obtained from a zener diode reference mounted on the driver coordination card. The lockout input locks out each gate pulse generator when a fault is detected by the monitor card and its fault relay. The control input determines the timing or phase shift of the gate pulse generator cards for control over the whole operating range. This input signal is obtained from the driver coordination card.

The driver coordination card compares a reference input and a voltage feedback and amplifies the resulting error signal to produce the control input signal to each gate pulse generator card. The reference signal is the reference input to the driver at Terminal 7. The voltage feedback signal is obtained from the SCR conversion module through Cable 2CA. This feedback signal is fed through the isolator card before being applied to the driver coordination card. The function of the isolator card is to provide electrical isolation of the driver circuitry with respect to the power circuitry in the SCR conversion module. The error signal, resulting from the

comparison of reference and feedback signals, is amplified by a differential amplifier and a second stage amplifier. This amplified output is fed to the gate pulse generators. Stabilization of this voltage regulator is accomplished by means of capacitor C737 at the input to the differential amplifier.

The driver coordination card also provides the protective functions of current limit and instantaneous overcurrent trip. A current feedback signal is obtained from the SCR conversion module through cable 2CA. A selected portion of this current signal is fed into the current limit spillover-amplifier circuit. At a selected current level, as set by the current limit potentiometer P738, the current limit amplifier turns on, turning off the second stage error amplifier. In order to obtain one-sixth cycle response, the current limit is a switching action which has no effective time delay. It therefore is dependent on and sensitive to the A-C ripple component in the armature current. In order to cover the range of ripple currents obtainable with different base speed motors, three current limit ranges can be selected in addition to the adjustment of the current limit potentiometer. These three ranges are obtained by jumper changes on the driver coordination card receptacle, as explained in driver elementary diagram note 7, for the different motor base speeds.

The current feedback signal is also applied to the static IOC switch circuit, which switches on at a preset current level, and remains on after current signal is removed. The output of this switch applies current limit to switch off the second stage error amplifier. The action of the static IOC function is also effective in one-sixth of a cycle, but is set at a higher current level than the current limit function. The static IOC circuit also provides a signal to the monitor card on tripping. It is reset by the action of the fault relay dropout on the monitor card.

The function of the monitor card is to detect fault conditions, open a fault relay interlock for operation of external magnetic fault circuitry, and indicate (by means of lights) what fault condition has occurred. The monitor card detects and indicates the following fault conditions:

1. Loss of one phase or wrong phase sequence.
2. Overcurrent resulting in operation of the static IOC circuit.

3. Overtemperature as measured by a thermostat on the SCR heat sink in the SCR conversion module.
4. Inverter type faults or D-C short circuits resulting in failure of D-C fuses. Inverter faults are possible, and the D-C fuse is provided, only if the drive is required to operate in the regenerative mode.

The fault relay RX855, will drop out, and the appropriately labeled indicating light on the front of the monitor card will light, when each of the above listed fault conditions is detected.

After the fault has been cleared, the monitor can be reset by operating the "control reset" pushbutton mounted directly above the monitor card on the driver pot bracket. This resetting will turn off the fault indicating light and allow the fault relay to again pick up.

The fault detection inputs to the driver must be connected, of course, for the monitor to function. The loss of phase or wrong phase sequence input is a three phase voltage input from the synchronizing transformer assembly through cable 5CA. This same three phase supply also provides voltage to the "power on" indicating light mounted on the driver pot bracket. The overcurrent input is an internal driver input from the driver coordination card as previously described. The overtemperature input is a normally closed thermostat contact input from the SCR conversion module through cable 2CA. Since cable 2CA also carries the voltage and current feedback signals, the overtemperature input performs a secondary detection function. If cable 2CA is disconnected, removing voltage, current and overtemperature feedback signals, the monitor will cause a fault shutdown the same as if the thermostat operated. The blown fuse input is obtained from the synchronizing transformer assembly through cable 5CA if a fuse failure card and a D-C armature fuse are provided. The fuse failure detector card, if provided, is mounted in the synchronizing transformer assembly.

The power supply card provides plus and minus 20 volts control power relative to common. It receives A-C input power from the power supply transformer, mounted on the synchronizing transformer assembly, through cable 5CA. It provides ± 20 volts control power to all of the driver cards, +20 volt power to the pulse amplifying circuitry on the SCR conversion module through cable 2CA, and can also provide a limited amount of ± 20 volt control power to the regulator.

REVERSING DRIVER

The operation of the reversing driver is best explained by referring to the elementary diagram contained in the diagram section. The operation of the reversing driver is quite similar to the operation of the nonreversing driver, and only those portions that are different will be described here. Therefore the nonreversing driver operation should be read and understood before proceeding further.

There are two sets of pulse train outputs from the reversing driver, one set for the forward SCR conversion module through cable 1CA, and a second set for the reverse SCR conversion module through cable 3CA. There are six identical gate pulse generator cards, three for forward operation and three for reverse operation. These gate pulse generators operate in the same way as described in the nonreversing driver section, with one oscillator card determining the pulse train frequency of all six gate pulse generators. The gate pulse generator A-C synchronizing voltages, which come from the synchronizing transformer assembly through cable 5CA, determine the phase relationship between the pulse trains in each set of gate pulse generators as described in the nonreversing driver section. The turn-off action between gate pulse generators in each set is also the same.

There are some differences in the three additional inputs to the gate pulse generators from those explained for the nonreversing driver. The peak point input is the same as explained before except that it feeds all six gate pulse generators. The lockout input is separate for the two sets of gate pulse generators and is a different function than that described for the nonreversing driver. The lockout input to the forward gate pulse generators is fed from the forward lockout switch of the driver coordination card whereas the lockout input to the reverse gate pulse generators is fed from the reverse lockout switch of the driver coordination card. The operating objective, as will be covered in the driver coordination explanation, is to lock out one set of gate pulse generators when the other set is turned on, and vice-versa. The control input, which determines the phase shift of the gate pulse generators as explained previously, is separate for the two sets of gate pulse generators. There are two control outputs of the driver coordination card, one to control the forward set of gate pulse generators, and one to control the reverse set.

The driver coordination card for the reversing driver performs more regulating and logic functions

than the nonreversing driver coordination card. The error signal, resulting from the comparison of the reference and voltage feedback signals, is amplified by a differential amplifier which has two outputs, one for a positive error input and one for a negative error input. The output for a positive error input feeds the forward amplifier, which in turn provides a control signal to the forward set of gate pulse generators. The output for a negative error input feeds the reverse amplifier, which in turn provides a control signal to the reverse set of gate pulse generators. The forward and reverse amplifiers also feed into the reverse and forward lockout switches respectively. In addition, the forward and reverse current feedbacks from the forward and reverse SCR conversion modules (by means of cables 2CA and 4CA) also feed into the reverse and forward lockout switches respectively. The outputs of the forward and reverse lockout switches act to turn off and lock out the forward and reverse amplifiers respectively. The lockout function performed by the above described circuitry is summarized as follows:

1. The forward amplifier, and therefore the forward set of gate pulse generators and the forward SCR conversion module, cannot be turned on until the reverse amplifier has been turned off and current has ceased in the reverse SCR conversion module.
2. The reverse amplifier, and therefore the reverse set of gate pulse generators and the reverse SCR conversion module, cannot be turned on until the forward amplifier has been turned off and current has ceased in the forward SCR conversion module.

The outputs of the forward and reverse lockout switches also act to lock out the forward and reverse sets of gate pulse generators respectively.

The protective functions of current limit and instantaneous overcurrent trip are performed the same as explained for the nonreversing driver. The only difference is that two current signals are fed back, such that the protective circuitry will operate equally well during forward or reverse operation. Three ranges of current limit may be selected as explained in note 8 on the driver elementary diagram.

The voltage feedbacks from the forward and reverse SCR conversion modules enter the driver by means of Cables 2CA and 4CA respectively, and are combined to obtain the correct polarity. This combined voltage feedback is then fed to the driver coordination card through the isolator card as explained for the nonreversing driver. A voltage limit potentiometer is mount-

ed on the driver pot bracket to limit the reference input to the driver coordination card.

The functional operation of the monitor card as explained for the nonreversing driver also applies equally to the reversing driver. The only difference is that thermostats from both the forward and reverse SCR conversion modules control the overtemperature circuit. Operation of either thermostat, or disconnection of either cables 2CA or 4CA, will cause a fault operation.

Operation of the power supply card is the same as explained previously for the nonreversing driver, except that it furnishes +20 volts control power to the pulse amplifying circuitry on both the forward and reverse SCR conversion modules through cables 2CA and 4CA.

SYNCHRONIZING TRANSFORMER ASSEMBLY

The major function of this assembly is to provide A-C control power to the driver. The same assembly is used to supply either the nonreversing or reversing drivers. This assembly contains four transformers to obtain electrical isolation and voltage transformation, as shown on the synchronizing transformer elementary diagram contained in the diagram section. One transformer provides A-C power to the two channels of the driver power supply card. The other three transformers have their primaries connected in delta across the three phase A-C supply lines. The secondaries of these transformers are connected in star with respect to driver common, to provide A-C synchronizing voltages to the driver gate pulse generators and three phase voltage to the driver monitor.

The A-C synchronizing voltages for the gate pulse generators are fed through three, 30 degree phase shift, filter networks to remove A-C line voltage spikes. These spikes result from the firing of the SCR's in the SCR conversion module and would affect the gate pulse generator synchronizing if not filtered out.

For regenerative drives containing D-C armature fuses, a fuse failure detector card is often used to detect failure of these fuses due to an inverter fault. This card, when used, is mounted in the synchronizing transformer assembly. It detects the voltage across a blown fuse, transforming and rectifying this voltage so that it can be fed to the driver monitor card to operate the blown fuse fault circuit. The fuse failure detector card can monitor from one to four fuses.

The synchronizing transformer assembly is normally mounted behind the driver rack and is connected to the driver by means of cable 5CA.

SIGNAL DISTRIBUTION ASSEMBLY

The function of this assembly is to distribute the pulse train and feedback signals from the driver to the SCR conversion modules. There are two types of this assembly, one for use with a nonreversing driver and one for use with a reversing driver.

A separate power supply is included as part of this assembly. This supply furnishes the plus 20 volts D-C power to operate the pulse amplifying circuitry in the SCR conversion modules, thus preventing the driver power supply from being overloaded.

A copy of the diagram which applies to the specific assembly supplied will be found in the diagram section.

OPERATION AND ADJUSTMENTS

GENERAL OPERATION

When A-C power is applied, the "power on" light mounted on the driver pot bracket will turn on. Unless a fault exists, the fault relay on the driver monitor card will immediately pick up, closing the interlock connected to driver terminals 11 and 12 for external magnetic circuit interlocking. A positive reference input to driver terminal 7 on a nonreversing driver will turn on the amplifier and advance the pulse train output of each gate pulse generator. A positive reference input to driver terminal 8 on a reversing driver will turn on the forward amplifier and advance the pulse train outputs of the forward gate pulse generators while locking out the pulse trains on the reverse gate pulse generators. A negative reference input to a reversing driver will turn on the reverse amplifier and advance the pulse train outputs of the reverse gate pulse generators while locking out the pulse trains on the forward gate pulse generators.

If a fault occurs, the fault relay on the monitor card will drop out, opening the interlock between driver terminals 11 and 12, and the appropriate fault indicating light on the front of the monitor card will light. The "control reset" pushbutton, located on the driver pot bracket, is operated to reset the monitor card relay and indicating lights after the fault has been cleared.

VOLTAGE LIMIT (ON REVERSING DRIVERS ONLY)

The "voltage limit" potentiometer, located on the reversing driver pot bracket, is adjusted to limit the motor armature voltage to 270 volts for a 250 volt rated drive, and to 540 volts for a 500 volt rated drive.

CURRENT LIMIT (PROTECTIVE)

The "current limit" potentiometer P738, located on the driver coordination card, is normally adjusted to limit motor armature current to 150% of rated value, but is adjustable from approximately 75% to approximately 200% of rated current. Since this current limit is dependent on armature ripple current, three different adjustment ranges are provided, dependent on motor base speed, to keep the current limit potentiometer adjustment in the above range. These three adjustment ranges are obtainable by tab jumper connections on the driver coordination card receptacle as denoted in the following table:

Motor Base Speed	Driver Coordination Card Jumper
2500 RPM	Tab 29 to Tab 20
1750 RPM	Tab 29 to Tab 22
1150 RPM and lower	None

STATIC IOC

This circuit has been factory adjusted by means of potentiometer P739 on the driver coordination card to operate at approximately 250% of rated current. If readjustment is found necessary, pry off the cap covering the second potentiometer hole from the bottom of the driver coordination card. Carefully insert a small screwdriver into the potentiometer center shaft hole and turn clockwise to increase IOC level and counter-clockwise to decrease IOC level. The range of adjustment is from approximately 125% to 300% rated current.

BIAS (OF GATE PULSE GENERATORS)

The gate pulse generator bias connectors have been factory adjusted to provide 150 degree phase retard at zero control input and at the A-C supply frequency stated on the nameplate. They also have had their adjustments trimmed, if necessary, to provide optimum racking of the firing points of the SCR's such that each SCR supplies the same amount of voltage and current to the D-C motor for balanced operation. Normally it should not be necessary to reconnect the bias settings.

An oscilloscope is required to check the bias selection if unbalanced operation occurs, the A-C supply frequency is changed, or misoperation occurs at high regenerative voltages. The procedure below should be followed in checking the bias settings of the gate pulse generators, since this is a critical adjustment.

1. On reversing drivers, disconnect one end of one of the pulse train cables 1CA or 3CA from the driver to the SCR conversion module (or from the driver to the signal distribution assembly, if a paralleled drive).
2. Jumper driver terminal board point 6 to point 1 (common) to clamp the driver coordination output to zero.
3. Using an instrument card in the driver test card position, connect the oscilloscope to the external connection jacks, observing the rules and recommendations on the use of the oscilloscope as explained in the "Trouble Shooting" section. For a reversing driver, place the instrument card in the forward test card position to check the forward gate pulse generator cards on the left hand side of the driver rack.
4. Apply A-C power to the drive and turn the instrument card selector switch to position 6. This control input voltage to the gate pulse generators should be approximately 0.6 volt. The unijunction emitter voltage wave shapes at selector positions 10, 11 and 12 should look like Figure 13 in the voltage waveshape check list in the "Trouble Shooting" section, if the biases are selected correctly. Also the peak points of each wave shape should be the same magnitude.
5. Turn the instrument card selector to position 13 and observe the unijunction output pulses. These pulses should appear the same as Figure 18 in the voltage wave shape check list, if the biases are selected correctly.
6. These bias connections have been factory set and tested for the application. Normally the bias connection on the card will agree with the drive input frequency as listed on the drive data nameplate (XA is 60 hz, XB is 50hz and XC is 45hz). Special applications, such as crane drives, will probably have a lower bias connection frequency to overcome any frequency shifts of the A-C input power source even when it is a 60hz input. When a replacement card is received it will have

a 60hz bias connection; check the other gate pulse generator cards to verify the proper bias connection point (other than 60hz). Special bias connections will also be stated on the drive elementary diagrams.

7. Repeat part 6 for the other two gate pulse generator cards.
8. For reversing drivers repeat parts 3, 4, 5 and 6 for the reverse gate pulse generator cards in the right hand side of the rack, placing the instrument card in the reverse test card position.
9. Reconnect the cable and remove the jumper (see parts 1 and 2).

ZERO ADJUST (NONREVERSING DRIVER ONLY)

The adjustment of the zero adjust potentiometer, P737 on the driver coordination card, is a factory adjustment which should not require readjustment. The following procedure should be used if checking or resetting of the zero adjust is found necessary.

1. Disconnect the control input to driver Terminal 7 and jumper Terminal 7 to Terminal 1 (common). Also jumper driver Terminal 1 to Terminal 14 to remove voltage feedback. Pull all three gate pulse generator cards from their receptacles. Using an instrument card in the driver test card position, turn the selector switch to position 6 (coordination output) and select the meter on in the X1 range.
2. Apply A-C power and check the coordination output voltage on the meter. It should be between zero and 0.4 volt.
3. If adjustment is required to obtain the correct value, pry off the cap covering the potentiometer hole directly beneath the "Current Limit" knob on the driver coordination card. Carefully insert a small screwdriver into the potentiometer center shaft hole, and slowly turn the potentiometer to obtain a coordination output between zero and 0.4 volt. Be sure to replace the cover cap. Also remove jumpers, plug in cards and connect wiring disconnected in part 1.

DEAD BAND AND ZERO ADJUST (REVERSING DRIVER ONLY)

The adjustment of dead band potentiometer P737 and zero adjust potentiometer P736 on the driver coordination card are factory adjustments which are quite critical. They should not be readjusted unless

some misoperation has been traced to this function. To check or readjust, use the following procedure:

1. Pull out all 6 gate pulse generator cards from their receptacles.
2. Disconnect the control input to driver Terminal 8 and jumper Terminal 7 to Terminal 1 (common). Also jumper driver Terminals 1 and 14 together to remove voltage feedback.
3. Use two instrument cards, one in the driver forward test position and the other in the driver reverse test position. Turn the selector switches for both test cards to position 6 (coordination output) and select both meters on in the X1 range.
4. Apply A-C power and check the forward and reverse coordination output voltages on the meters. They should both be the same and be in the range of zero to 0.4 volt. If one exceeds 0.4 volt, or if excessive dead band or incorrect zero adjust is suspected, proceed as follows:
5. Pry off the caps covering the bottom and third from the bottom potentiometer holes on the driver coordination card. (Check driver coordination card elementary diagram contained in the diagram section to make sure the correct potentiometers are being adjusted.) Carefully insert a small screwdriver into the center shaft hole of dead band potentiometer P737 (directly beneath the "Current Limit" knob). Slowly turn this potentiometer counterclockwise to obtain an output on the instrument card meters. Do not exceed 0.4 volt output on either meter. If the outputs of the two meters differ in magnitude, balance them by adjusting the zero adjust potentiometer P736. It may be necessary to alternately adjust the dead band and zero adjust potentiometers several times in order to get them both the same and in the zero to 0.4 volt range. Be sure to replace the cover caps, plug in the cards, and replace the wiring disconnected or jumpered in parts 1 and 2.

TROUBLE SHOOTING

GENERAL APPROACH

When incorrect operation is first noticed, it is often possible to reduce the overall servicing time by studying the symptoms in order to localize the trouble. A good understanding of the functional operation, as explained in the "Principles of Operation" section, will be very helpful in isolating the problem. A systematic check of voltages and voltage wave shapes and comparison of them with the correct readings, as given later in this section, should reveal the source of many malfunctions.

If the trouble is localized to one printed circuit card, this card should be replaced with a good spare, and the driver operation should be rechecked. It may be necessary to trim the bias adjustment on a replacement gate pulse generator card.

The use of a good quality oscilloscope is required to properly trouble shoot this equipment. The vertical gain and the sweep speed should be calibrated to allow interpretation of observations.

WARNING

High Voltage. Electric shock can cause serious or fatal injury. Whether the AC voltage supply is grounded or not, high voltages to ground will be present at many points within the SCR drive. Extreme care must be exercised in the selection and use of test instruments.

Operators should not stand on grounded surfaces or be in contact with ground when applying test instruments to test points. Test instruments should not have chassis grounded while tests are being made. Extreme care should be taken during the use of test instruments, such as an oscilloscope, since their chassis will be at a high voltage with respect to ground during testing.

CHECKING FOR MALFUNCTIONS

1. "Loss of Phase" light indicates and drive shuts down or will not start
 - (a) Check for correct phase sequence at A-C power terminals of SCR conversion assembly.
 - (b) Check A-C supply voltage to determine if one phase is open.
 - (c) Check for extremely wide notches in A-C supply voltage caused by other SCR drives. Refer to General Electric Co. for recommendations on A-C line filtering. (Note: When using an oscilloscope without a differential amplifier to check the operation of the driver, the common (chassis) lead of the oscilloscope should be connected only to circuit common. Connecting the oscilloscope common lead to any other point(s) in the driver may cause improper operation in drive by permitting firing of SCR's at incorrect times).
2. "Overcurrent" light indicates and drive shuts down (due to IOC trip)
 - (a) Check for D-C short circuits or grounds, or for extreme, suddenly applied, motor overloads.

-
- (b) Check for current limit being set too high and/or static IOC set too low. See "Operation and Adjustments" section of this instruction.
 - (c) Check for excessive rate of rise of input signals due to improper switching of jog reference, etc.
 - (d) Check dead band and zero adjust settings on reversing drivers if shutdown occurs when going through zero current (crossover). See "Operation and Adjustment" section of this instruction. Also check lockout operation by referring to voltage wave shape check list in this sector.
- 3. "Overtemperature" light indicates and shuts down drive**
- (a) Check for overheating in SCR conversion module (see trouble shooting notes in GEK 11015A).
- 4. "Blown Fuse" light indicates and shuts down drive (reversing or regenerative operation only)**
- (a) Check for blown D-C armature fuses (see trouble shooting notes in GEK 11014A).
 - (b) Check dead band and zero adjust settings on reversing drives (see "Operation and Adjustments" section). Also check lockout operation on reversing drivers at test point 2 (see voltage wave shape check list in this section).
- 5. Fault relay on monitor card does not pick up (no fault lights on)**
- (a) Check for presence of +20 volts D-C at monitor card tab 30. Also check for voltage at monitor card tab 27 (driver terminal 10). If voltage is present at both points, relay is defective and monitor card should be replaced. Refer to card printed circuit diagram in the diagram section.
- 6. Current Limit doesn't work or not adjusted correctly**
- (a) Check current limit setting per notes in "Operation and Adjustments" sections of this instruction and the SCR conversion assembly instruction GEK 11014A. If current limit does not work, replace driver coordination card with good spare and recheck.
- 7. Can't obtain required phase shift range of gate pulse trains**
- (a) Check phase shift range by disconnecting one end of the pulse train output cable (either 1CA or 3CA) from the driver to the SCR conversion module. Monitor the pulse train outputs at instrument card selector positions 14 through 19 (see driver elementary diagram) with an oscilloscope while slowly applying reference to the driver input. If some or all of the pulse trains will not phase shift approximately 150 degrees, the gate pulse generator bias selections should be checked (see "Operation and Adjustments" section).
 - (b) If disconnecting the pulse train cable in part (a) allows adequate phase shift range, check adjustment of the voltage limit potentiometer on reversing drives. Also check maximum reference voltage to driver.
- 8. Incorrect power supply voltage**
- (a) Check for +20 volts ± 0.5 volt and -20 volts ± 0.5 volt, referring to the voltage check list on the driver elementary diagram. If voltage is not correct or is missing, check A-C output voltages of power supply transformer on the synchronizing transformer assembly, between terminals 22 to 23 and 24 to 25. Both of these voltages should be 25 volts ± 3 volts A-C. If A-C supply voltage is present, check voltages at power supply card tabs per the printed circuit card diagram in the diagram section, and if the voltages are not correct, the card should be replaced.
- 9. Unbalanced output pulses (output voltage)**
- (a) Check bias selection of gate pulse generators (see "Operation and Adjustments" section).
 - (b) Check A-C synchronizing and unijunction emitter voltage wave shapes at test points 7, 8, 9, 10, 11 and 12 and compare with those given in the voltage wave shape check list in this section. If one or more wave shapes differ greatly, that gate pulse generator card should be replaced with a good spare, and the balance rechecked.
 - (c) Check output of coordination card at test point 6 and compare with Figure 10 or 11 given in the voltage wave shape check list in this section.

If wave shape differs greatly, the driver coordination card may be defective. Replace with a good spare and recheck.

10. No A-C synchronizing voltage to the gate pulse generators at test points 7, 8 and 9

- (a) Check synchronizing voltage output of synchronizing transformer assembly at terminals A5, A6, B5, B6, C5 and C6 with respect to common terminal 21. If voltage is present there, check cable 5CA connecting synchronizing transformer assembly with driver. If one or more voltages not present, check transformer outputs at terminals A7, A8, B7, B8, C7 and C8 with respect to common terminal 21. Also check transformer input voltages between terminals A1 to A4, B1 to B4 and C1 to C4.

11. "Power on" light does not indicate

- (a) Check voltage across indicating light terminals on back of driver pot bracket. If this voltage is over 90 volt D-C, light is defective and should be replaced. If voltage is low or zero, check voltage output of synchronizing transformer assembly terminals A7, B7 and C7 with respect to common terminal 21. These voltages should each be about 45 volts A-C. Check cable 5CA for continuity. If A-C input voltage to monitor card is correct, replace this card with good spare and recheck.

12. Wrong pulse train phase sequence (test points 14 through 19)

- (a) Check phase sequence of A-C supply to synchronizing transformer assembly; it should be 1-2-3 for input leads T1, T2 and T3.

13. No output pulse trains (test points 14 through 19)

- (a) Check oscillator output at monitor card tab 26 to common. It should be a square wave oscillation between zero and plus 20 volts, the time being about 20 to 30 microseconds at zero and about 60 to 70 microseconds at 20 volts. If this voltage oscillation not present, replace entire monitor card with good spare card and recheck.

- (b) On reversing driver, check lockout operation at test point 2. Lockout must be released (go to 20 volts) before pulse trains can appear.

14. Output pulses continuous, not train of pulses (test points 14 through 19)

- (a) Check oscillator output at monitor card tab 26 to common. It should be a square wave oscillation between zero and plus 20 volts, the time being about 20 to 30 microseconds at zero and about 60 to 70 microseconds at 20 volts. If this voltage oscillation is not present, replace entire monitor card with good spare card and recheck.

15. One or more pulse trains missing; one or more other pulse trains on continuously (test points 14 through 19)

- (a) Replace the gate pulse generator card associated with the missing pulse train per the voltage check list on the driver elementary diagram. With a good spare card in its place, recheck the pulse train outputs.

16. One or all pulse train outputs of nonoperating portion of reversing driver not locked out when opposite portion is operating (test points 14 through 19)

- (a) If all pulse trains in nonoperating portion are not locked out, check lockout operation at test point 2 (refer to voltage wave shape check list). The lockout voltage should be 18 to 19 volts when not locked out and is 0 to 1 volts when lockout is applied. If lockout does not switch modes when switching coordination card outputs (from tab 5 to tab 9 and vice-versa, at test points 6), the coordination card is probably defective and should be replaced.

- (b) If only one pulse train remains on, replace the gate pulse generator card associated with that pulse train per the voltage check list on the driver elementary diagram. Recheck after replacing with good spare card.

17. One or more unijunction emitter voltage wave shapes distorted or missing (test points 10, 11 and 12)

- (a) Replace the gate pulse generator card associated with the distorted or missing voltage wave shape per the voltage check list on the driver elementary diagram. Recheck after replacing with good spare card.

18. Small reference input voltage produces full output

- (a) Check reference and voltage feedback voltages at test points 3 and 4 respectively. If voltage feedback missing, check SCR conversion module(s) and cables 2CA and 4CA between conversion module and driver. If feedback voltage is present but not at test point 4, the isolator card is probably defective. Replace with good spare card and recheck.

19. Crossover between operating conversion modules on reversing drivers is too sluggish or is too jumpy.

- (a) Check dead band and zero adjust settings (see "Operation and Adjustments" section of this instruction).

20. Misoperation at high regenerative voltages

- (a) Check gate pulse generator bias selections (see "Operation and Adjustments" section of this instruction).

VOLTAGE CHECK LIST

Refer to the voltage check list on the applicable driver elementary diagram in the diagram section.

VOLTAGE WAVE SHAPE CHECK LIST

The following check list figures are oscilloscope pictures of voltage wave shapes taken across the output jacks of an instrument card inserted into the driver test receptacle. This check list is derived from the voltage check list contained on the driver elementary diagram. The test points 1 through 19 correspond to the instrument card selector positions, and are also shown in blocks on the elementary diagram. Where identical readings (except for phase relationship) are encountered on the gate pulse generator cards, only one picture is shown, representative of all cards.

The oscilloscope pictures in Figures 1 through 19 show correct voltage wave shapes for the operating conditions stated. If the readings taken do not agree with these wave shapes, the card involved, or the card or component feeding the signal into the card involved, should be suspected of being faulty. A good spare card should be substituted for the suspected card and the reading retaken.

There are two test card positions on a reversing driver, one for the forward portion and the other for the reverse portion of the driver control. Care should be taken to avoid confusion between the readings of the operating and nonoperating portions of the driver control.

<u>Voltage Description</u>	<u>Test Points</u>	<u>Card Involved</u>	<u>Tab No.</u>	<u>Fig. No.</u>
D.C. supply, positive and negative	1,2*	Power Supply	27(+) 12(-)	1
Lockout, off and on	2*	Coordination	10, 18	2
Reference	3	Coordination	25	3
Voltage feedback, motoring, under load	4	Coordination	26	4
Voltage feedback, motoring, no load	4	Coordination	26	5
Voltage feedback, regenerating, under load	4	Coordination	26	6

<u>Voltage Description</u>	<u>Test Points</u>	<u>Card Involved</u>	<u>Tab No.</u>	<u>Fig. No.</u>
Voltage feedback, regenerating, no load	4	Coordination	26	7
Current feedback, under load	5	Coordination	28, 27	8
Current feedback, at zero current†	5	Coordination	28, 27	9
Coordination output, under load	6	Coordination	5, 9	10
Coordination output, no load	6	Coordination	5, 9	11
A.C. synchronizing voltage	7, 8, 9	Gate Pulse Generators	5	12
Unijunction emitter, phased off (150°)	10, 11 12	Gate Pulse Generators	22	13
Unijunction emitter, low output, no load	10, 11 12	Gate Pulse Generators	22	14
Unijunction emitter, half output, under load	10, 11 12	Gate pulse Generators	22	15
Unijunction emitter, half output, in current limit	10, 11 12	Gate Pulse Generators	22	16
Unijunction output, phased partially forward	13	Gate Pulse Generators	4	17
Unijunction output, biased off (150°)	13	Gate Pulse Generators	4	18
Pulse train output	14, 15, 16 17, 18, 19	Gate Pulse Generators	20, 12	19

*Test point 2 on a nonreversing driver is the negative power supply voltage, whereas on a reversing driver, test point 2 is the lockout voltage.

†The current feedback wave shape at zero current is obtained when the SCR conversion module is off on a non-reversing driver, and is obtained when the opposite SCR conversion module is operating on a reversing driver.

The six pulse train outputs have a definite phase relationship with each other. The correct order in time (left to right on oscilloscope) is 2SCR, 4SCR, 3SCR, 5SCR, 1SCR, 6SCR, 2SCR, 4SCR, etc. The correct order referred to the test point or instrument card selector position is 15, 17, 16, 18, 14, 19, 15, 17, etc. The correct phase shift between adjacent pulse trains is 60 degrees. (See Figure 20)

APPENDIX

This appendix contains a more detailed description of the functional operation of each printed circuit card contained in the driver module. The operation of each card is best understood by referring to the functional schematic given in this section and to the printed circuit diagram contained in the diagram section.

GATE PULSE GENERATOR (193X725AAG01)

Figure 21 is a functional schematic of the gate pulse generator. The printed circuit diagram will be found in the diagram section.

There are a number of inputs to the gate pulse generator card which must be properly connected in order for it to operate correctly. The peak point input at tab 21 sets the maximum voltage of the ramp plus the platform at which the pulse generator produces an output pulse. The A.C. synchronizing voltage inputs at tabs 6 and 7 synchronize the pulse generator and alternator circuits to the A.C. supply voltage. The #1 and #2 turn off inputs at tabs 10 and 11 come from another gate pulse generator which is synchronized 120 degrees later in its operation. They turn off the #1 and #2 amplifiers 120 degrees after they have been turned on by pulse generator (through the alternator).

With no special input voltage applied to tab 3, the input voltage to the pulse generator is the ramp voltage alone since the platform is only about 0.6 volt. The ramp is adjusted by means of resistor selection to reach the peak point voltage in about 170 degrees, or at the instant when the pulse generator is being reset by the A-C synchronizing circuit. This reset occurs twice a cycle, or every 180 degrees, with the reset being applied for approximately 10 degrees. The pulse produced by the pulse generator, because of the reset, is called the tail end pulse and is synchronized at the 150 degree phase back condition of the SCR bridge.

Three nominal resistor selections, one each for 60, 50 and 45 Hertz operation are built into the card. Stab on XA is 60hz, XB is 50hz and XC is 45hz.

The output of the pulse generator is applied to the alternator circuit. Since the pulse generator produces two pulses per cycle, each card can control two SCR's

which should be fired 180 degrees apart. The alternator circuit is synchronized to the A.C. line so as to correctly apply the pulse generator output alternately to either the #1 or the #2 amplifier circuits. This alternate selection is required during regenerative operation to prevent shoot-thru faults in the SCR conversion module.

Each amplifier circuit is turned on at alternate times by the pulses produced by the pulse generator. A positive feedback maintains the amplifier on after the pulse disappears, until it is turned off by its respective turn off input 120 degrees later. The main output of each amplifier is fed to its respective modulator circuit. A second input to each modulator is the oscillator input at tab 26. The function of the oscillator input is to change the continuous 120 degree output of each amplifier into a 120 degree wide train of pulses which can be applied to a pulse transformer. The #1 and #2 pulse train outputs appear at tabs 20 and 12 respectively.

A second output of each amplifier circuit performs several important functions. These are the #1 and #2 turn-off outputs at tabs 18 and 16 which are fed to the preceding gate pulse generator to turn off its amplifiers, which had been turned on 120 degrees earlier. These same amplifier outputs are also fed back to clamp the alternator output and the platform voltage. Each amplifier output clamps the input to the opposite amplifier, by means of diodes D471 and D472, to prevent the possibility of both amplifiers ever being turned on together. This clamping provides additional protection against shoot-thru faults during regenerative operation. The amplifier outputs also clamp the platform voltage by means of diodes D469 and D470. The result is that platform voltage is applied for only a 60 degree interval prior to the start of each pulse train output. This clamping restricts pre-firing, especially during current limit operation.

The lockout input at tab 8 turns off both the #1 and #2 amplifier through diodes D484 and D485. This turns off the gate pulse generator outputs completely, also removing the 150 degree phase back condition caused by the tail end pulse.

Three test point tabs are included for voltage checking inside the gate pulse generators. Tab 22 gives the summation of ramp and platform voltage at the unijunction emitter. Tab 5 gives the A-C synchronizing voltage for pulse generator reset. Tab 4 gives unijunction pulse generator output to the alternator. These three voltages, plus the pulse train output voltages at tabs 20 and 12, are part of the driver voltage check list given on the driver elementary diagram. They are monitored by using an instrument card plugged into the driver test receptacle.

DRIVER COORDINATION—NONREVERSING (193X740AAG01)

Figure 22 is a functional schematic of the non-reversing driver coordination card. The printed circuit diagram will be found in the diagram section.

The two main inputs to the driver coordination card are the reference input to tab 25 and the voltage feedback to tab 26, both with respect to common (tabs 19 or 20). These two signals are summed and the error difference is fed into the differential amplifier. This error can be monitored at tab 30. Capacitor C737 is the stabilizing capacitor. If additional stabilizing is required, capacitor C736 can be added by connecting tab 24 to common (tab 19 or 20). The zero adjust potentiometer P737 sets the operating level of the differential amplifier to obtain zero output at tab 5 for zero input. The output of the differential amplifier feeds the second stage amplifier, which in turn produces the output at tab 5.

A current feedback signal is connected with its positive polarity to tab 28 and its negative polarity to tab 16. This current signal is fed into both the current limit circuit and the static IOC circuit. At a level of current feedback signal determined by the setting of the current limit potentiometer P738, the current limit spillover-amplifier circuit turns on, turning off the second stage amplifier. In order to obtain fast response, the current limit operates as a switching circuit having no effective time delay. The current limit action is dependent on and sensitive to the A-C ripple component in the D-C current feedback. In order to cover the range of ripple current magnitudes encountered, three current limit ranges are selectable by means of tabs 29 and 22. These tabs can be connected together or to common to short out diodes in the current limit spillover circuit.

The static IOC circuit is switched on at a predetermined level of current feedback signal, as set by the

IOC adjust potentiometer P739. This circuit remains on after current signal is removed. The reset output of this switch turns off the second stage amplifier through a portion of the current limit circuit. This output also connects to tab 11 for external resetting of the static IOC circuit. Another output of this circuit connects to tab 14 to provide a signal for external tripping and monitoring.

A zener diode voltage reference circuit is connected to tab 8 to provide peak point reference voltage to the gate pulse generators.

DRIVER COORDINATION—REVERSING (193X726AAG01)

Figure 23 is a functional schematic of the reversing driver coordination card. The printed circuit diagram will be found in the diagram section.

The two main inputs to the driver coordination card are the reference input to tab 25 and the voltage feedback to tab 26, both with respect to common (tabs 19 or 20). These two signals are summed and the error difference is fed into the differential amplifier. This error can be monitored at tab 30. Capacitor C737 is the stabilizing capacitor. If additional stabilizing is required, capacitor C736 can be added by connecting tab 24 to common (tabs 19 or 20). The differential amplifier has two outputs, one for a positive error input which feeds the forward amplifier, and the other for a negative error input which feeds the reverse amplifier. The forward and reverse amplifiers in turn produce outputs at tabs 5 and 9 respectively. The zero adjust and dead band potentiometers, P736 and P737 respectively, set the operating level of the differential amplifier to obtain zero output at both tabs 5 and tab 9 for zero input, and also zero dead band between these two outputs.

Two current feedback signals are required; the forward current feedback has its positive and negative polarities connected to tabs 28 and 16 respectively, and the reverse current feedback has its positive and negative polarities connected to tabs 27 and 17 respectively. These two current signals are both fed into the current limit circuit and the static IOC circuit, and are individually fed into the forward and reverse lockout circuits.

The current limit spillover-amplifier circuit turns on at a level of current feedback signal determined by the setting of the current limit potentiometer P738. The output of this circuit turns off both the forward and

reverse amplifiers. In order to obtain fast response, the current limit operates as a switching circuit having no effective time delay. The current limit action is dependent on and sensitive to the A.C. ripple component in the D.C. current feedback. In order to cover the range of ripple current magnitudes encountered, three current limit ranges are selectable by means of tabs 29 and 22. These tabs can be connected together or to common to short out diodes in the current limit spillover circuit.

The static IOC circuit is switched on at a predetermined level of current feedback signal, as set by the IOC adjust potentiometer P739. This circuit remains on after current signal is removed. The reset output of this switch turns off the forward and reverse amplifiers through a portion of the current limit circuit. This output also connects to tab 11 for external resetting of the static IOC circuit. Another output of this circuit connects to tab 14 to provide a signal for external tripping and monitoring.

The forward current signal is fed into the reverse lockout circuit and the reverse current signal is fed into the forward lockout circuit, both in a direction to turn the lockout circuits on. In addition, the output of the forward amplifier turns the reverse lockout circuit on, and the output of the reverse amplifier turns the forward lockout circuit on. The output of the forward lockout circuit prevents the forward amplifier from being turned on and produces an output at tab 10 to lock out the forward gate pulse generators. The output of the reverse lockout circuit prevents the reverse amplifier from being turned on and produces an output at tab 18 to lock out the reverse gate pulse generators. Both lockout circuits may be turned on through the lockout input at tab 23.

A zener diode voltage reference circuit is connected to tab 8 to provide peak point reference voltage to the gate pulse generators.

SIGNAL ISOLATOR (193X728AAG01)

Figure 24 is a functional schematic of the signal isolator card. The printed circuit diagram will be found in the diagram section.

The function of the isolator card is to provide electrical isolation of its output from its input, when feeding it with a D.C. signal of either polarity. The signal is fed into the isolator at tabs 28 and 23. This D.C. signal is chopped up in the inverter circuit and fed into the isolation transformer as a square wave A.C. signal. The output of the isolation transformer is rectified back into a D.C. signal in the converter circuit, and the output appears at tabs 3 and 10.

The oscillator circuit operates from 20 volts D.C. and produces an A.C. square wave at a frequency of approximately 5KC. This A.C. controls the chopping frequency of the inverter and converter circuits, synchronizing them together so that the converter produces an output of the same polarity as the input signal. If the input is positive at tab 28, the output will be positive at tab 3, and vice-versa.

The output signal will contain some high frequency spikes due to the chopping action in the inverter and converter circuits. This is removed by filter capacitor C357 if tab 10 is connected to tab 11. However, when the isolator is used in the voltage feedback loop of the driver, this filter capacitor is not connected (and is not required) since it would cause the voltage regulator to be unstable. Tab 19 is a test point to check the operation of the oscillator circuit.

MONITOR-OSCILLATOR (193X737AAG01)

Figure 25 is a functional schematic of the monitor card and the oscillator card, which is physically mounted on the monitor card. The printed circuit diagrams will be found in the diagram section.

The function of the monitor card is to detect fault conditions, operate a fault relay, and indicate by means of lights what fault condition has occurred. This card has four fault detecting and indicating circuits; loss of one phase or wrong phase sequence, overcurrent, blown fuse, and overtemperature. The loss of phase circuit operates on a signal from the phase sequence and 120 volt supply circuit. This circuit is supplied from all three A.C. phases by means of tabs 14, 10 and 7. Part of this circuit monitors the three phase to phase voltages and produces an output to the loss of phase circuit if one phase is lost or if the phase sequence is wrong. The other part of the circuit is a 120 volt D.C. supply to the indicating lights in the four fault detecting and indicating circuits, and to the output at tab 28 to supply the driver "power on" light. The overcurrent circuit operates on a signal input to tab 29 coming from the static IOC circuit on the driver coordination card. The blown fuse circuit operates on a signal input to tab 3 coming from the fuse failure detector card. The overtemperature circuit operates from the opening of the circuit from tab 21 to common, which is normally maintained closed by the thermostat mounted in the SCR conversion module.

The outputs of all four fault detecting circuits turn off the normally energized fault relay RX855. The normally open and normally closed interlocks of this

relay are brought out to tabs 17, 25, 19 and 24 respectively for external circuit operation. The fault relay is maintained off after a fault by the fault detecting circuits until reset by shorting tab 27 to common. This also resets the fault indicating circuits.

The oscillator card produces a continuous train of pulses which is fed to each gate pulse generator card to control the pulse width and pulse frequency of the pulse train outputs. The oscillator circuit generates this continuous pulse train, which is fed to the amplifier circuit, and in turn is supplied to the output at tab 26. To prevent gate pulse generator output during initial energizing of the power and control circuits, an initial timer circuit keeps the oscillator amplifier turned off for the first second after energizing. After this period of time, output will appear at tab 26. If an output pulse from the oscillator card is desired at some particular instant when the oscillator circuit might be off, the amplifier can be triggered by a pulse introduced at tab 12.

POWER SUPPLY (193X741AAG01)

Figure 26 is a functional schematic of one channel of this two channel power supply, since the other channel is identical. The printed circuit diagram will be found in the diagram section.

The power supply card has two 24 volt A.C. inputs at tabs 10 and 11 and tabs 22 and 23. These are fed from a dual secondary power supply transformer external from the card. The power supply card has two 20 volt D.C. outputs, each of which is capable of supplying 1 amp maximum. Since the two channels of this card are identical, only one will be described.

The rectifier changes the A.C. voltage into D.C. which is fed into the power regulator and filter circuit. This circuit filters out the A.C. ripple in the rectified voltage, and by means of a power transistor, regulates the D.C. voltage to the output tabs. The power transistor is controlled by the differential amplifier and second stage amplifier circuits. The reference voltage to the differential amplifier is taken from the zener reference diode Z129. The feedback voltage is obtained from the bridge resistors R143 and R145 which are selected to obtain the correct power supply output voltage of between 19.5 to 20.5 volts. The differential amplifier circuit takes the error difference between reference and feedback voltages and feeds it into the second stage amplifier circuit. This circuit amplifies the signal to control the power transistor, producing enough gain to obtain very precise power supply output voltage regulation.

DC POWER SUPPLY (POSITIVE)

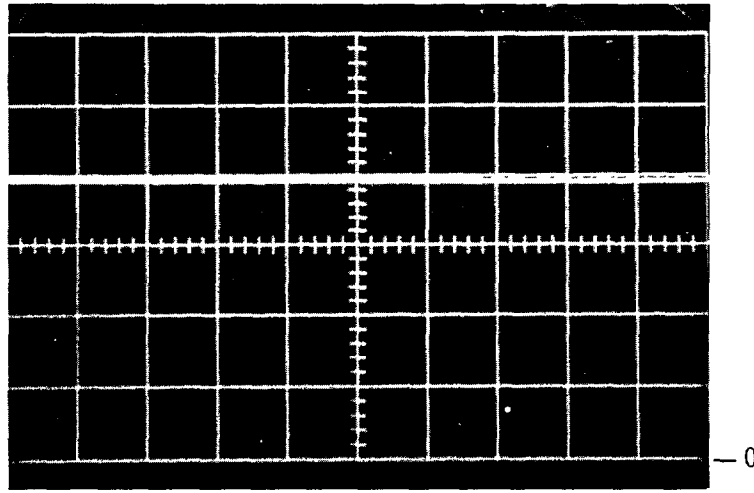

CALIB.
VERT.
5 VOLTS/CM
HORIZ.
2 MS/CM

FIGURE 1

LOCKOUT (OFF AND ON)

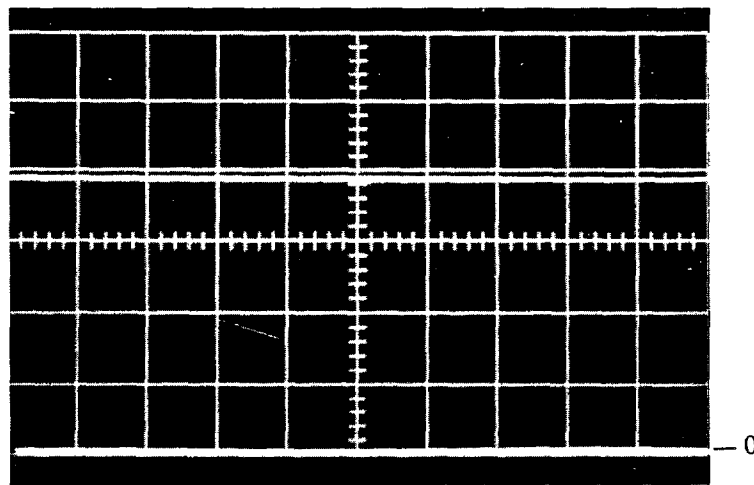

CALIB.
VERT.
5 VOLTS/CM
HORIZ.
2 MS/CM
TOP
TRACE—OFF
BOTTOM
TRACE—ON

FIGURE 2

REFERENCE

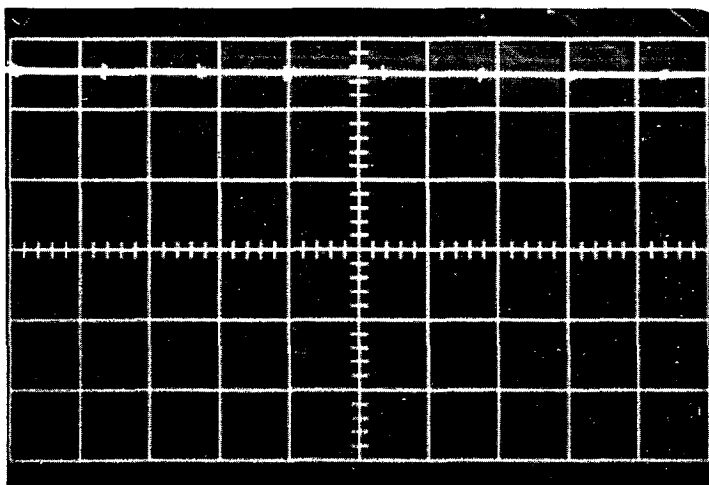

CALIB.
VERT.
2 VOLTS/CM
HORIZ.
2 MS/CM

FIGURE 3

VOLTAGE FEEDBACK (MOTORING, UNDER LOAD)

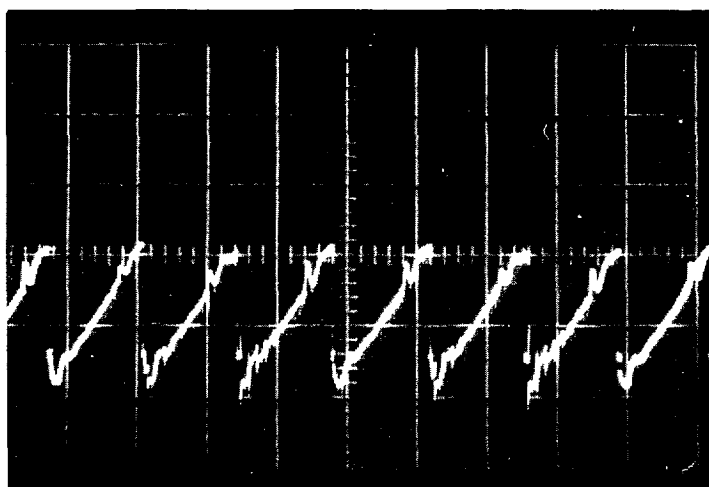

CALIB.
VERT.
5 VOLTS/CM
HORIZ.
2 MS/CM

FIGURE 4

VOLTAGE FEEDBACK (MOTORING, NO LOAD)

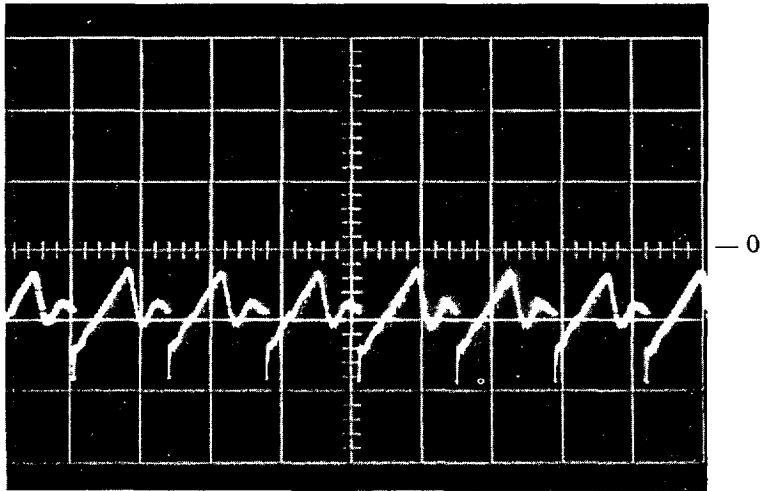

CALIB.
VERT.
5 VOLTS/CM
HORIZ.
2 MS/CM

FIGURE 5

VOLTAGE FEEDBACK (REGENERATING, UNDER LOAD)

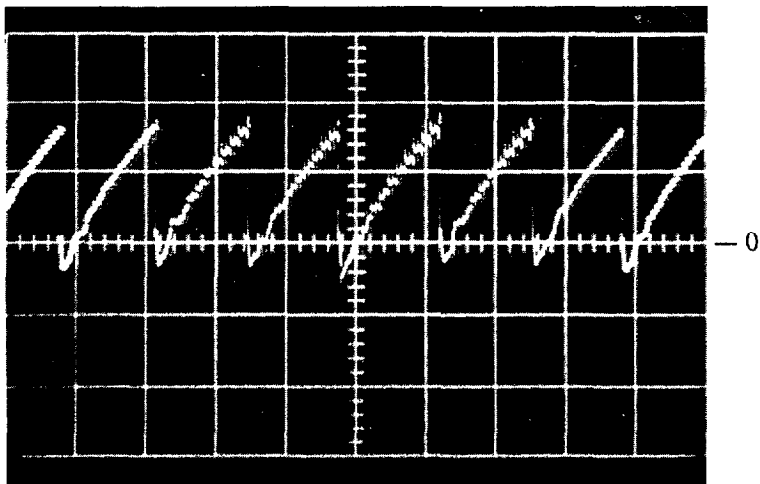

CALIB.
VERT.
5 VOLTS/CM
HORIZ.
2 MS/CM

FIGURE 6

VOLTAGE FEEDBACK (REGENERATING, NO LOAD)

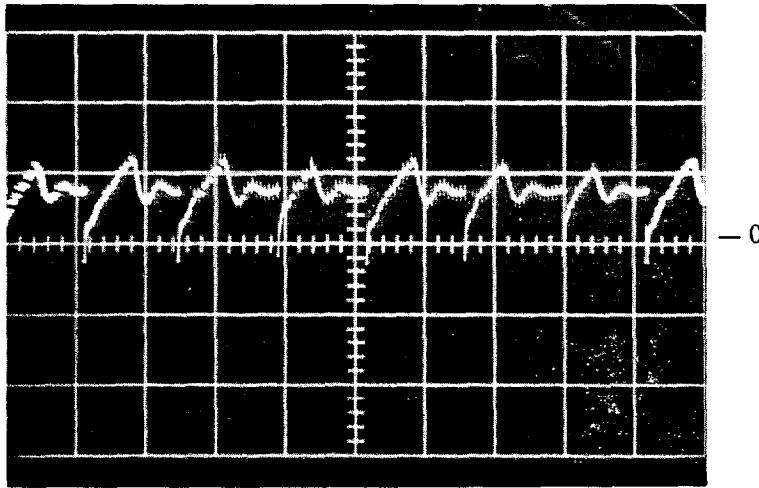

CALIB.
VERT.
5 VOLTS/CM
HORIZ.
2 MS/CM

FIGURE 7

CURRENT FEEDBACK (UNDER LOAD)

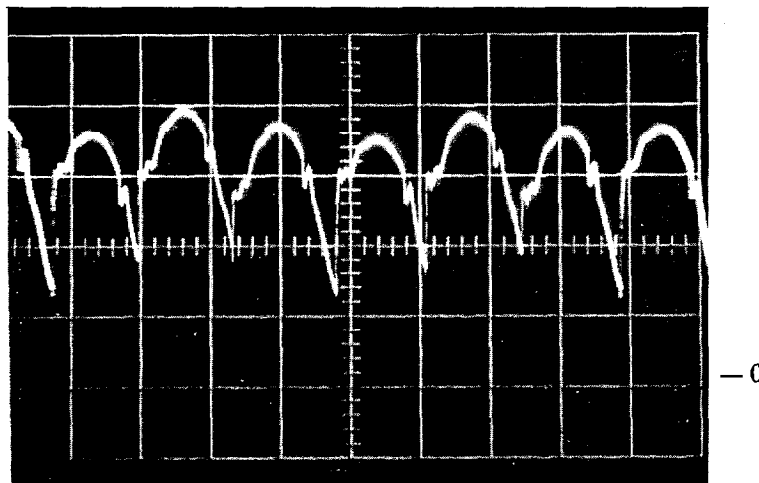

CALIB.
VERT.
1 VOLT/CM
HORIZ.
2 MS/CM

FIGURE 8

CURRENT FEEDBACK (AT ZERO CURRENT)

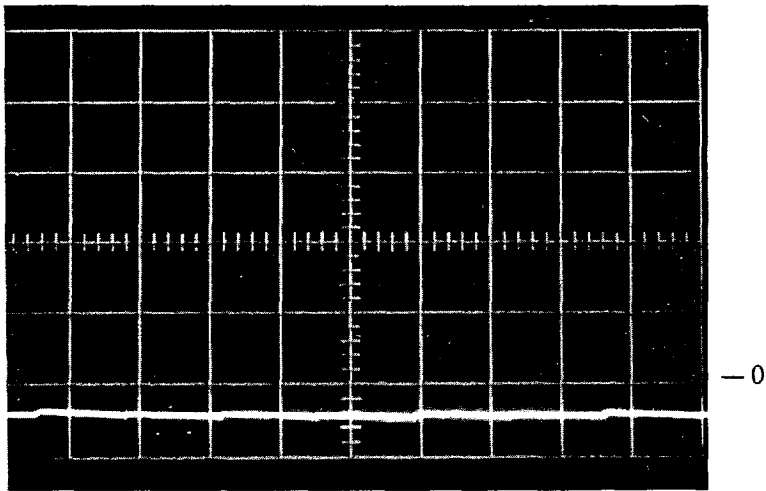

CALIB.
VERT.
1 VOLT/CM
HORIZ.
2 MS/CM

FIGURE 9

COORDINATION OUTPUT (UNDER LOAD)

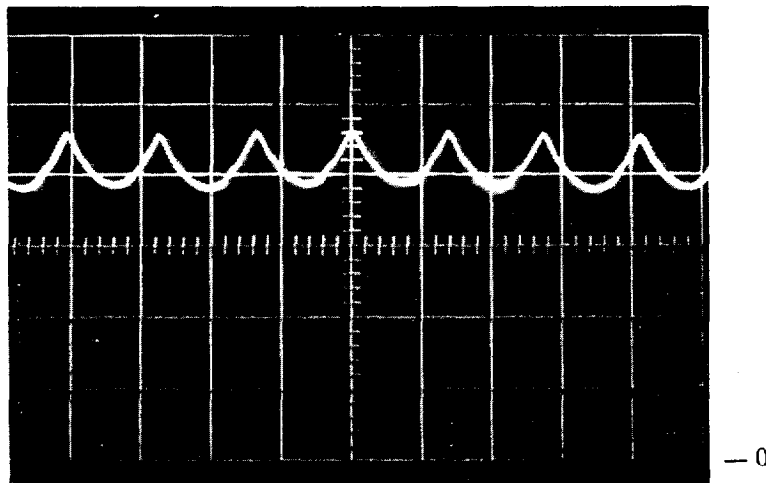

CALIB.
VERT.
1 VOLT/CM
HORIZ.
2 MS/CM

FIGURE 10

COORDINATION OUTPUT (NO LOAD)

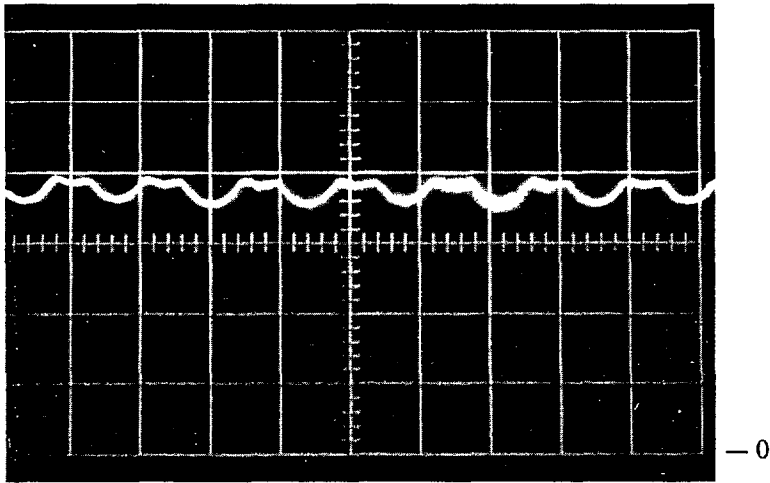

CALIB.
VERT.
1 VOLT/CM
HORIZ.
2 MS/CM

FIGURE 11

AC SYNCHRONIZING VOLTAGE

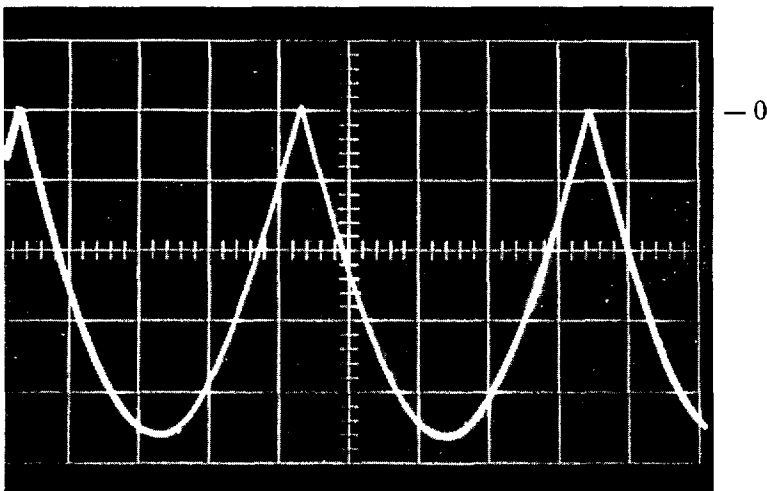

CALIB.
VERT.
10 VOLTS/CM
HORIZ.
2 MS/CM

FIGURE 12

UNIUNCTION EMITTER (PHASED OFF—150°)

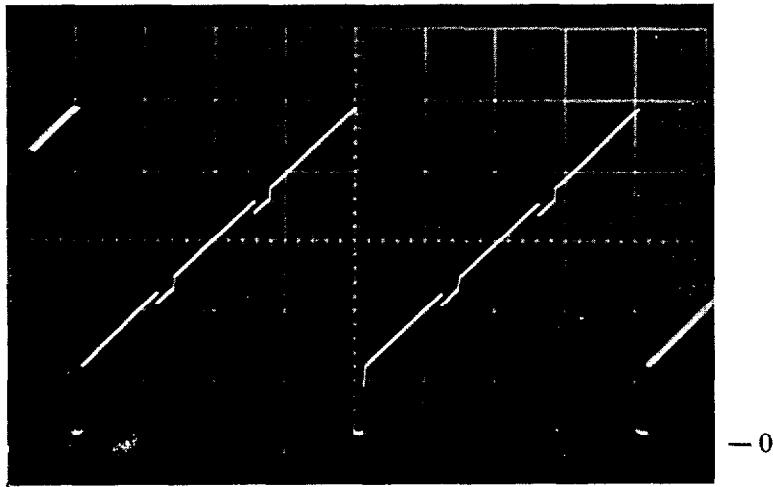

CALIB.
VERT.
2 VOLTS/CM
HORIZ.
2 MS/CM

FIGURE 13

UNIUNCTION EMITTER (LOW OUTPUT, NO LOAD)

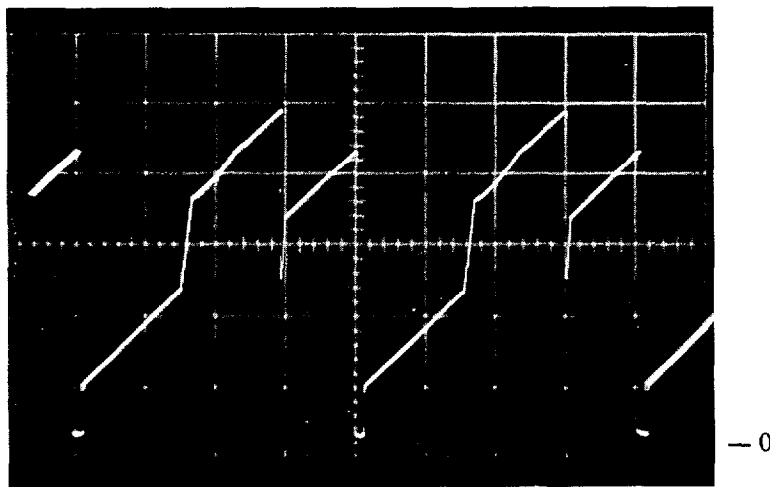

CALIB.
VERT.
2 VOLTS/CM
HORIZ.
2 MS/CM

FIGURE 14

UNIUNCTION EMITTER (HALF OUTPUT, UNDER LOAD)

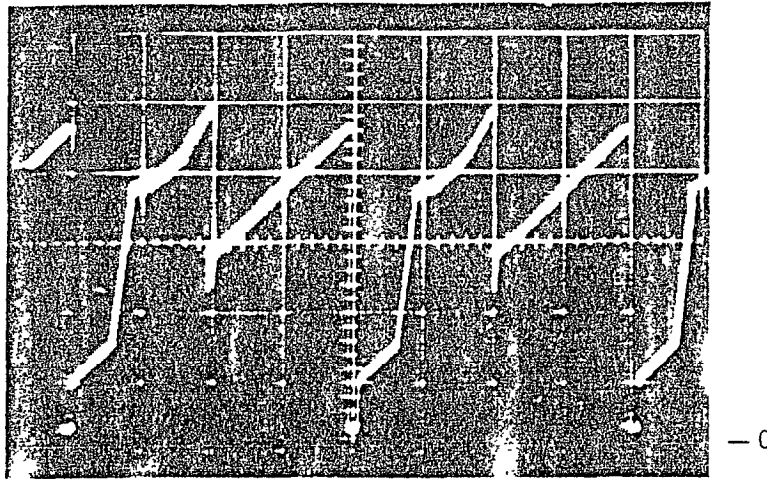

CALIB
VERT
2 VOLTS/CM
HORIZ
2 MS/CM

FIGURE 15

UNIUNCTION EMITTER (HALF OUTPUT, IN CURRENT LIMIT)

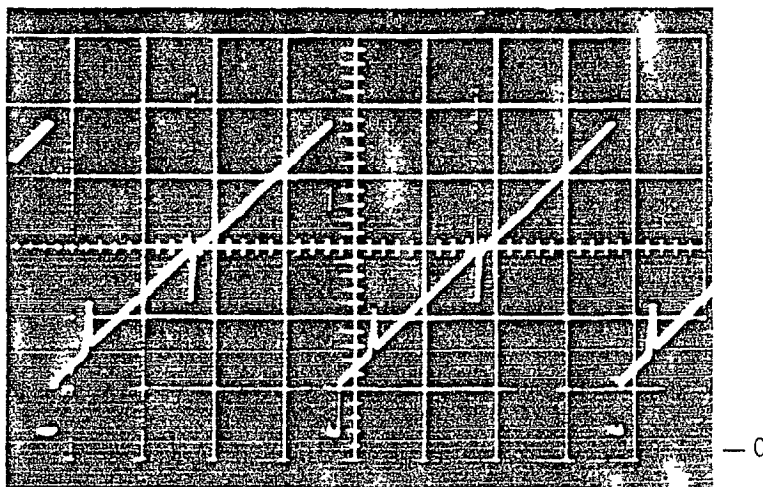

CALIB.
VERT.
2 VOLTS/CM
HORIZ.
2 MS/CM

FIGURE 16

UNIUNCTION OUTPUT (PHASED PARTIALLY FORWARD)

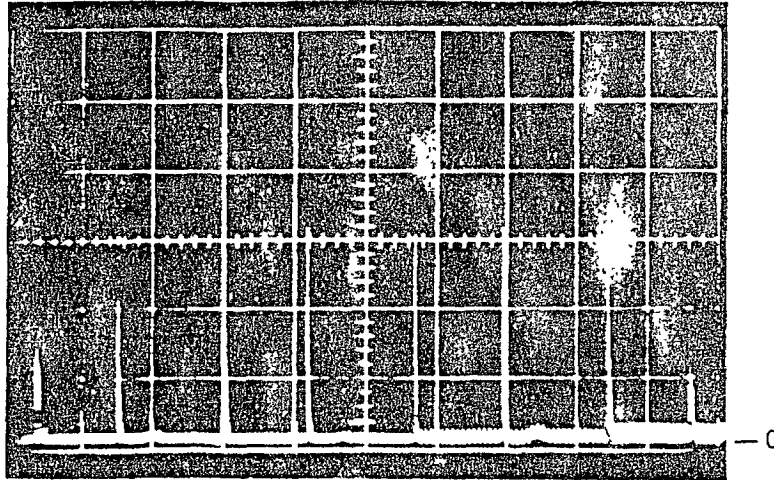

CALIB.
VERT
2 VOLTS/CM
HORIZ
1 MS/CM

FIGURE 17

UNIUNCTION OUTPUT (BIASED OFF-150°)

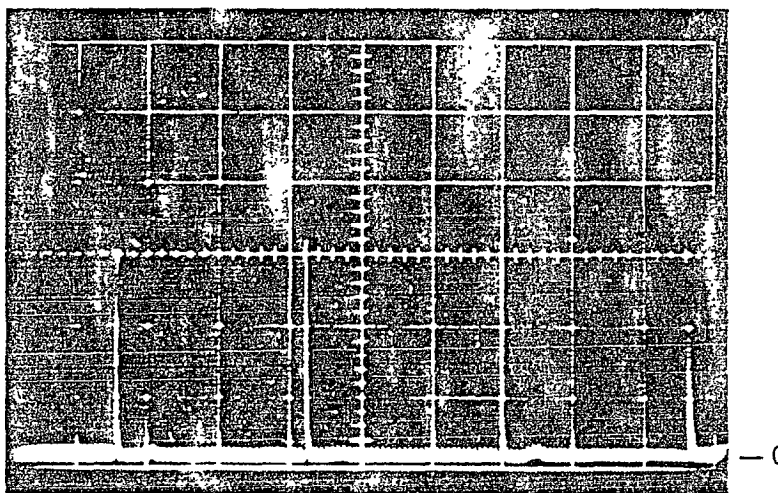

CALIB.
VERT.
2 VOLTS/CM
HORIZ.
1 MS/CM

FIGURE 18

PULSE TRAIN OUTPUT

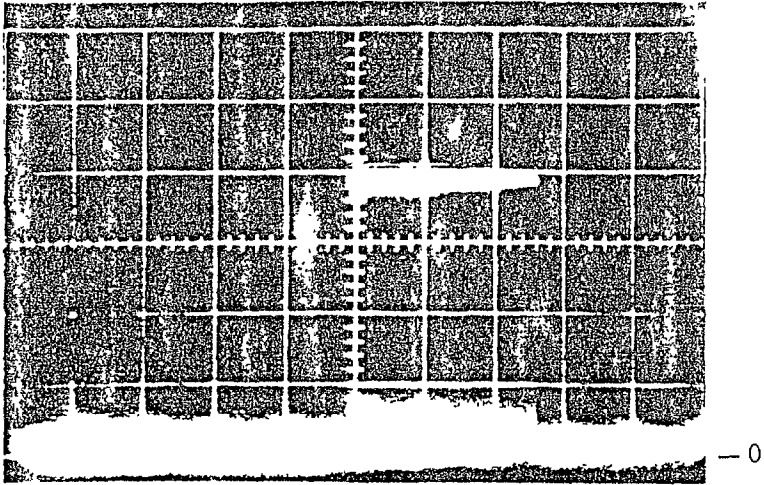

CALIB.
VERT
5 VOLTS/CM
HORIZ.
2 MS/CM

FIGURE 19

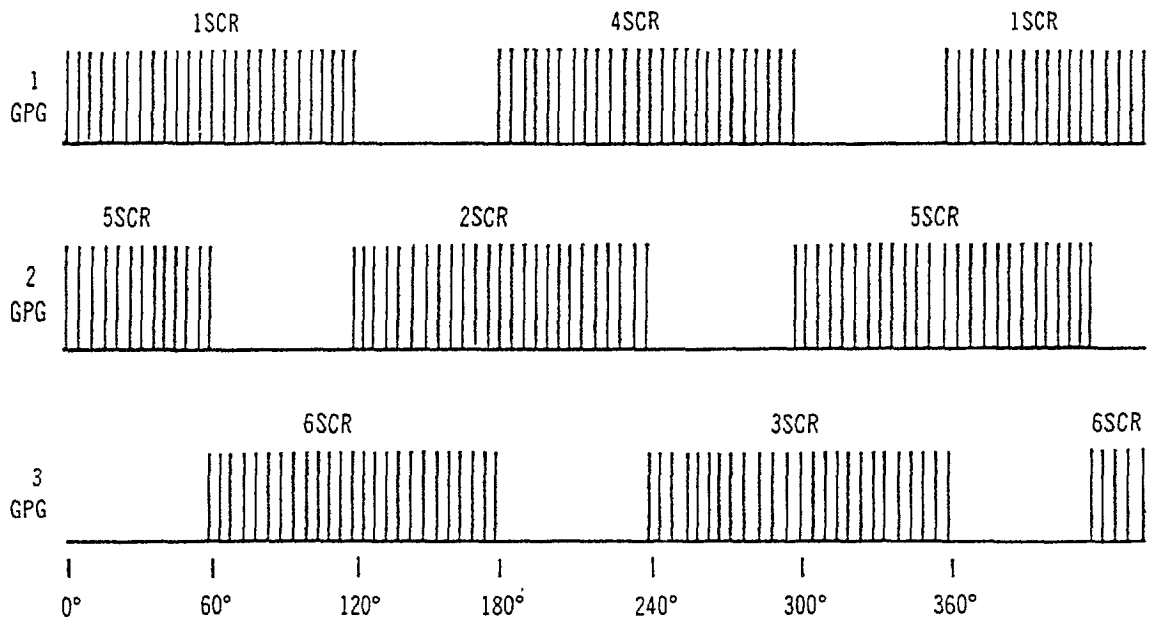

FIGURE 20

GATE PULSE GENERATOR

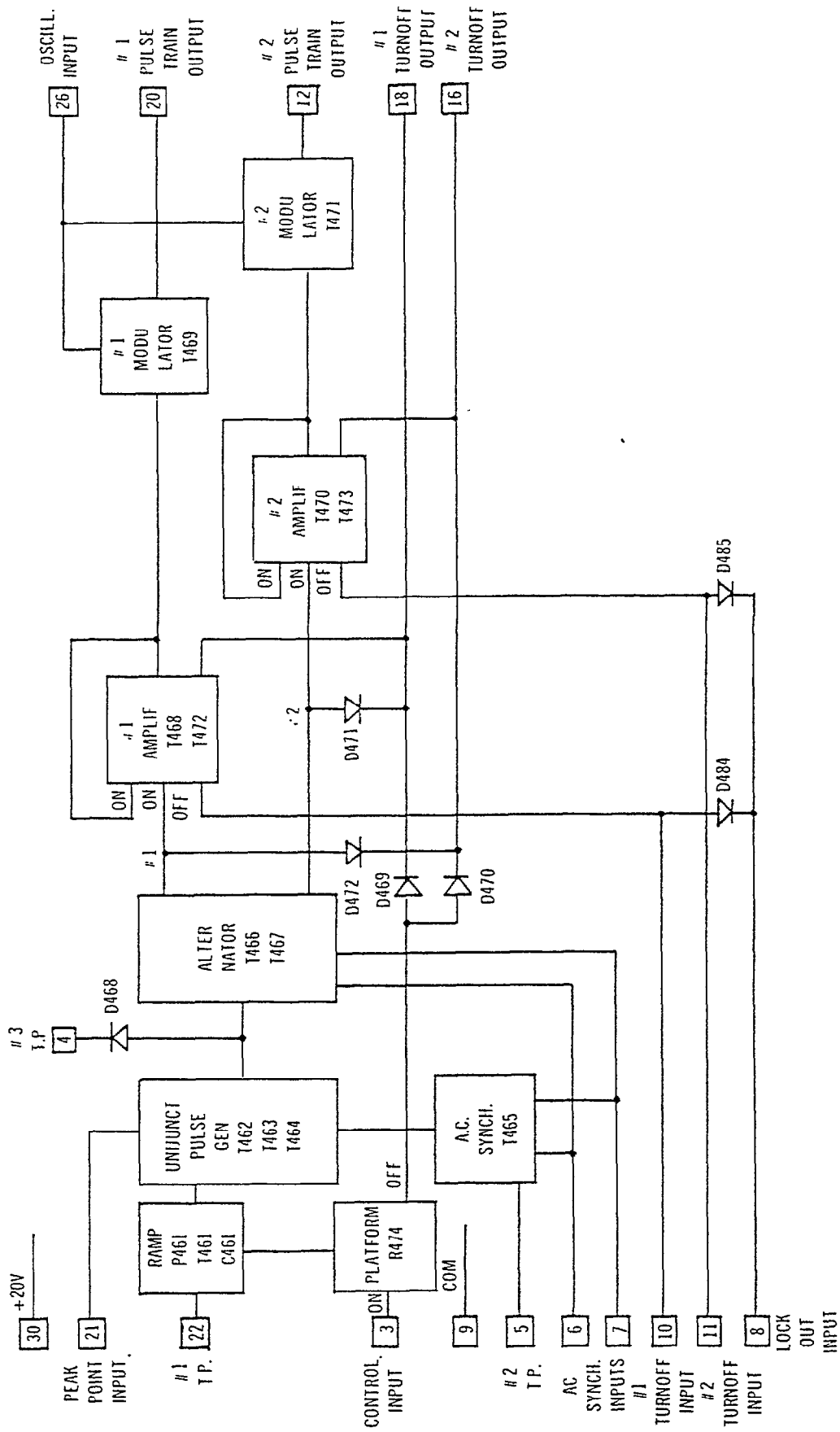

FIGURE 21

DRIVER COORDINATION (NON REVERSING)

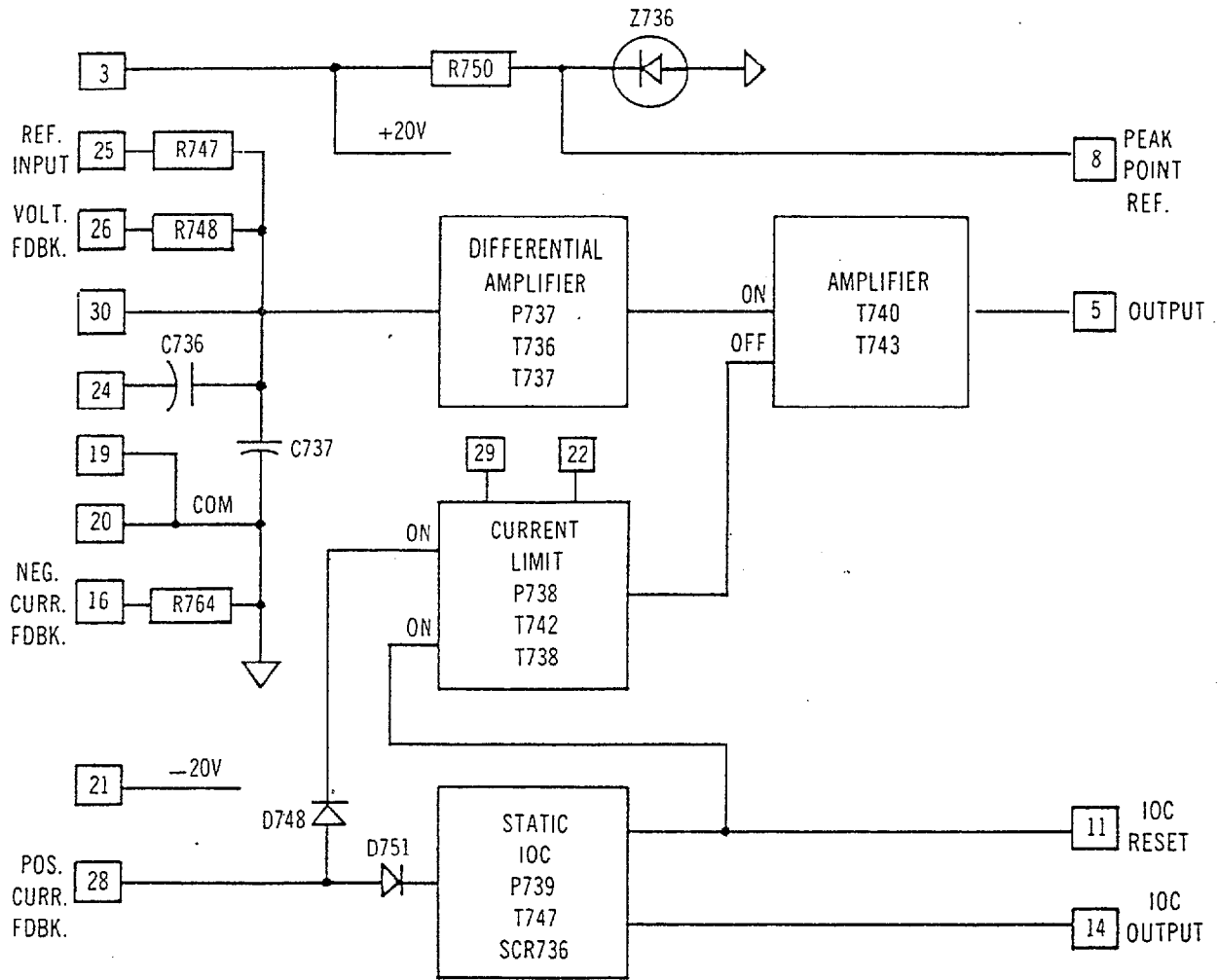

FIGURE 22

DRIVER COORDINATION (REVERSING)

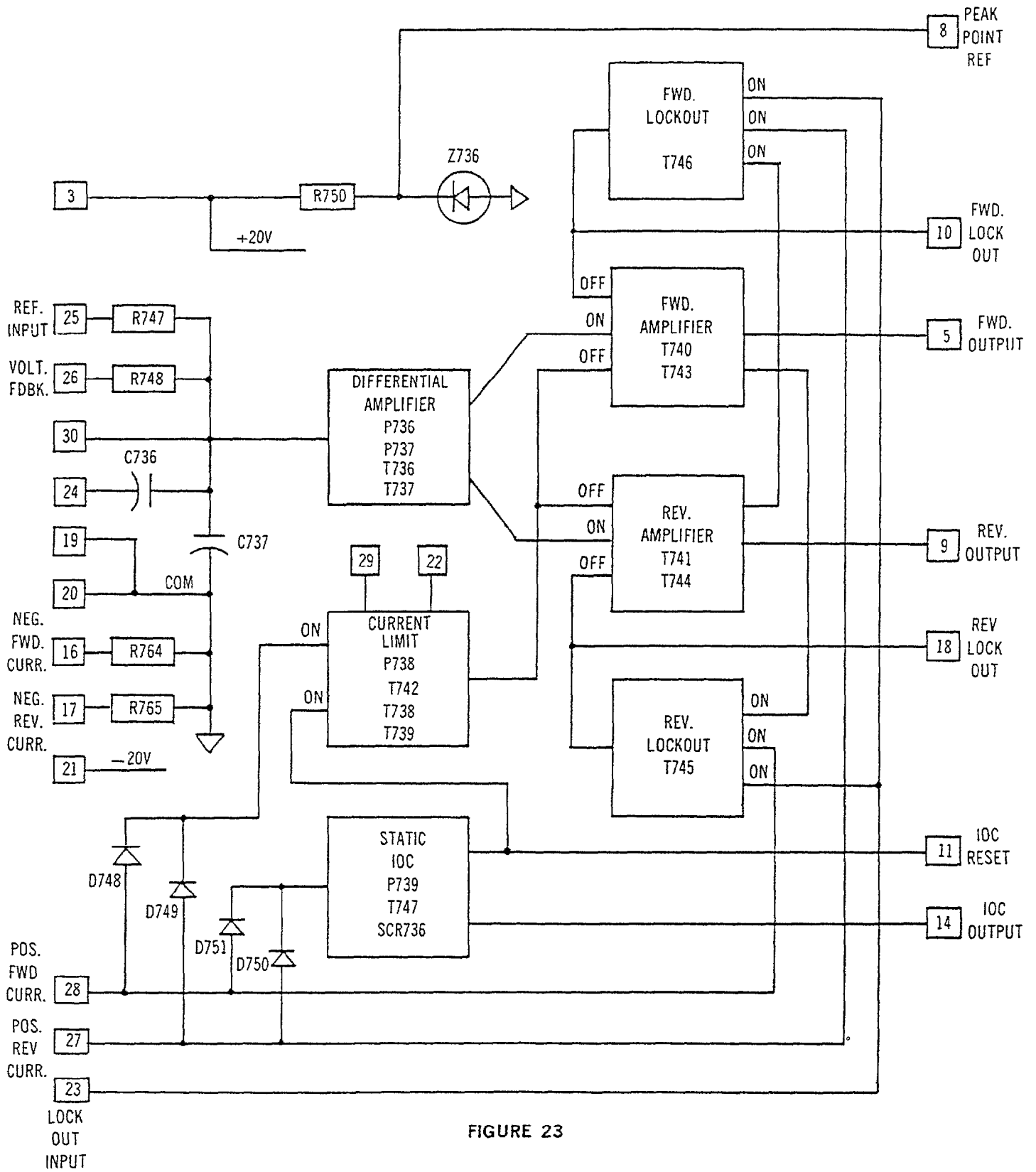

FIGURE 23

SIGNAL ISOLATOR

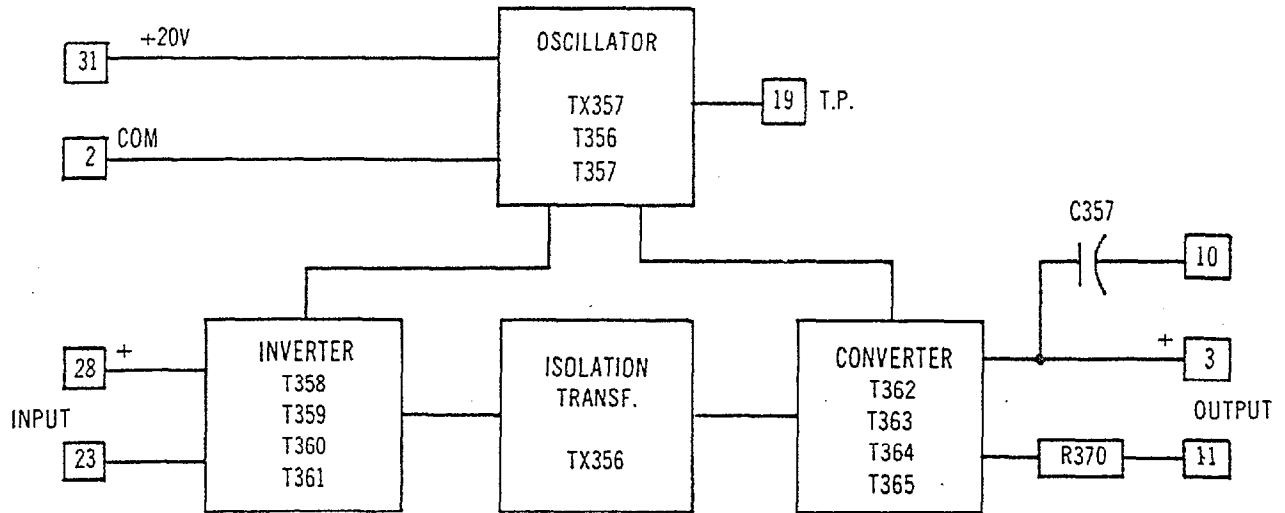

FIGURE 24

MONITOR—OSCILLATOR

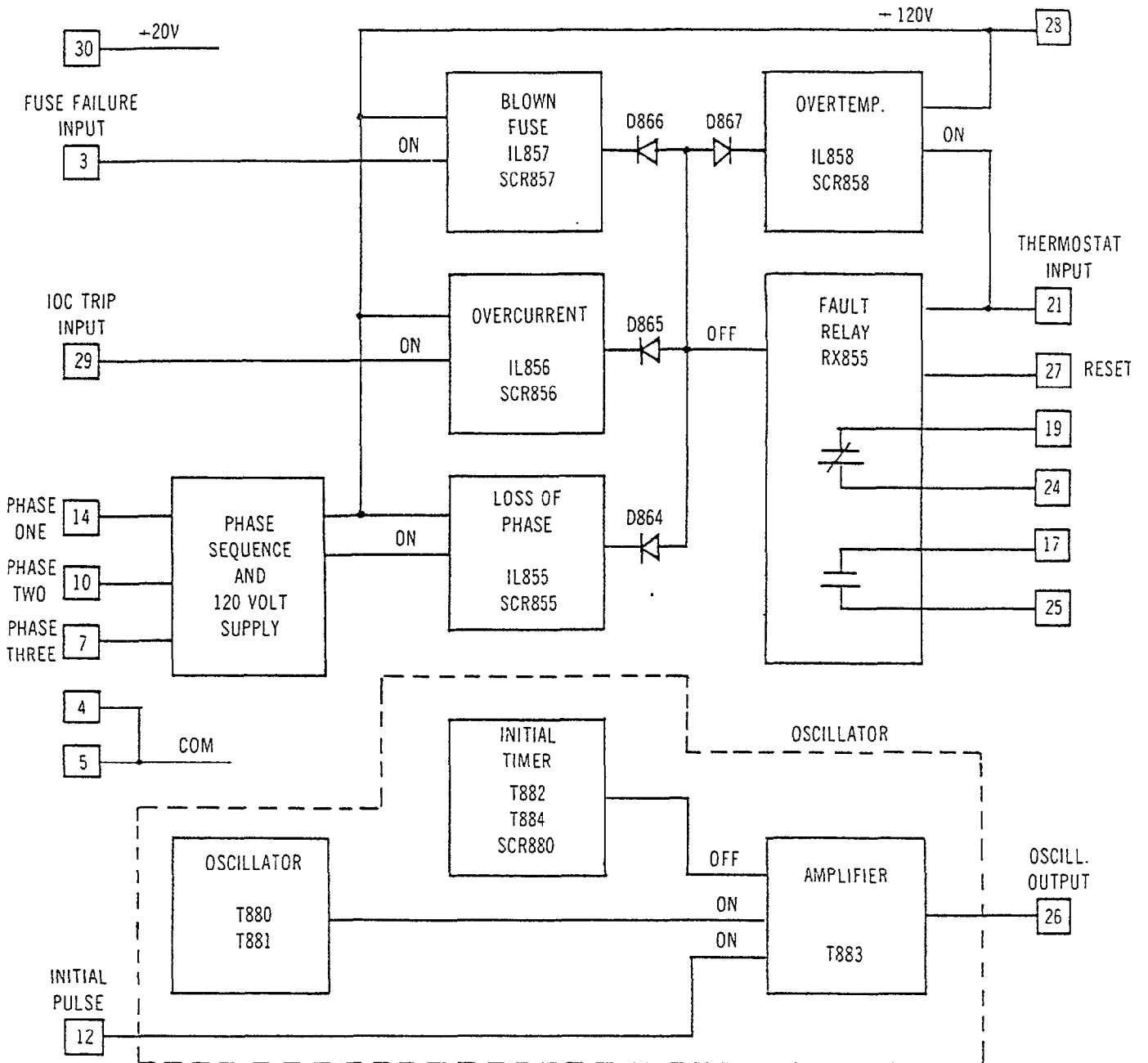

FIGURE 25

POWER SUPPLY (BOTTOM CHANNEL)

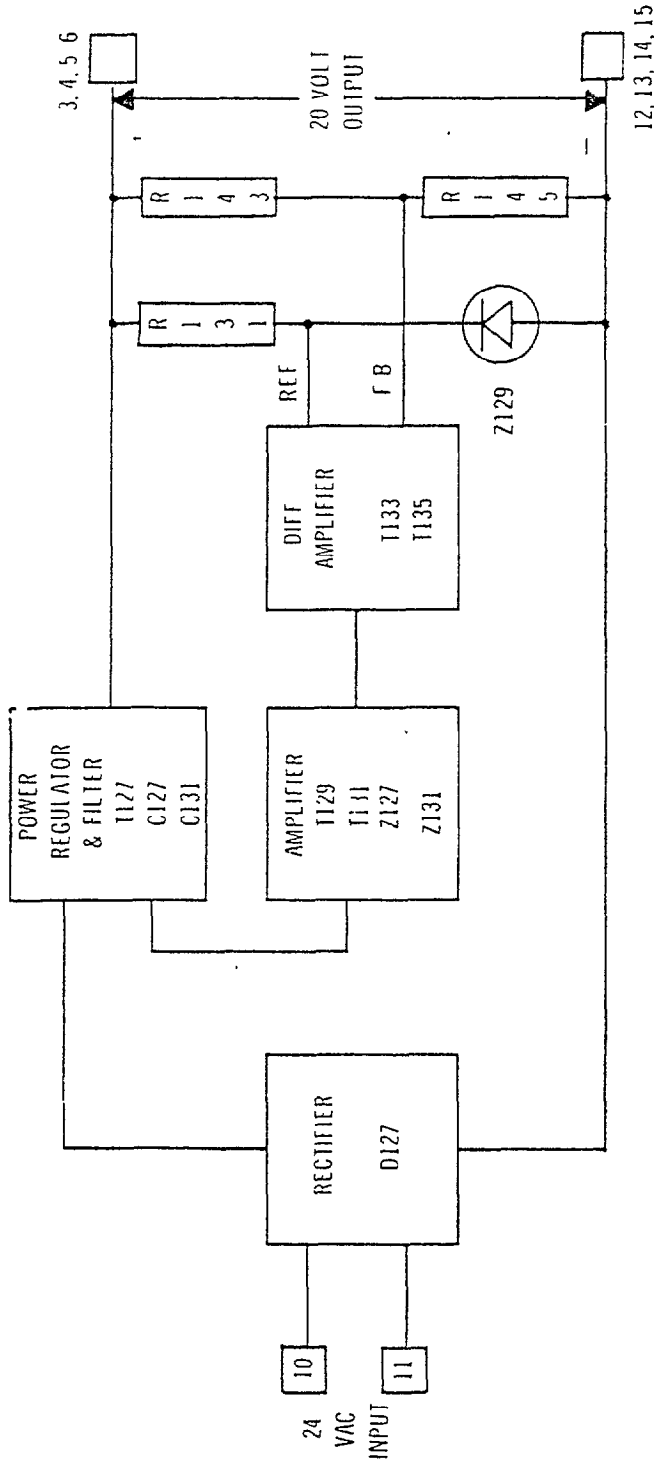

FIGURE 26

NOTES

GENERAL ELECTRIC COMPANY – DC MOTOR & GENERATOR DEPARTMENT
SPEED VARIATOR PRODUCTS OPERATION
ERIE, PENNSYLVANIA 16531

GENERAL  ELECTRIC