



INSTRUCTIONS

STATIC TIME-OVERCURRENT RELAY

12SFC151A,B(-)A

12SFC152A,B(-)A

12SFC153A,B(-)A

12SFC154A,B(-)A

12SFC177A,B(-)A

12SFC178A,B(-)A

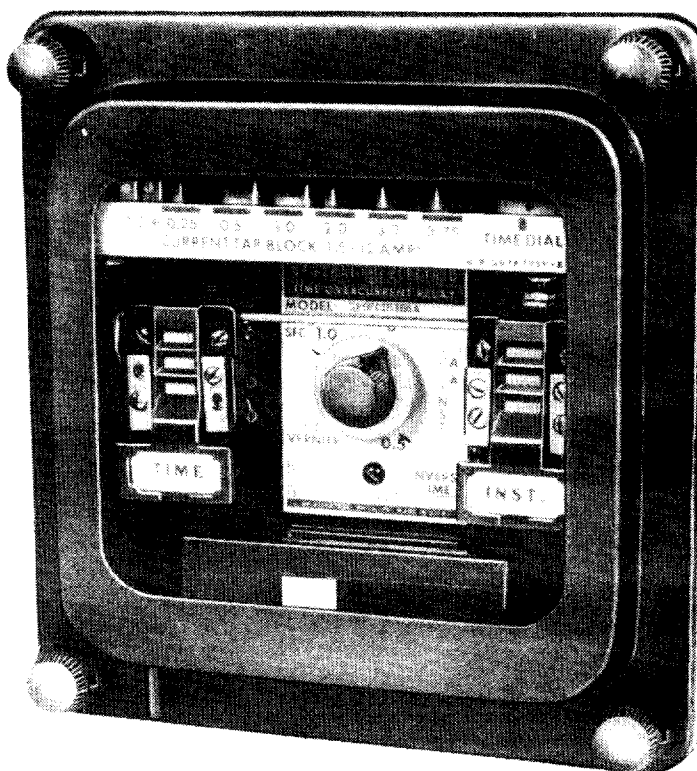

GE Protection and Control
205 Great Valley Parkway
Malvern, PA 19355-1337

CONTENTS

	<u>PAGE</u>		<u>PAGE</u>
DESCRIPTION.....	3	2. Power Requirements, General	18
APPLICATION.....	5	3. Time-Overcurrent Unit.....	19
RATINGS.....	6	a. Pickup Calibration Check	19
A. Time-Overcurrent Unit.....	6	b. Time Calibration Check..	20
B. High-Seismic		4. High-Seismic Instantaneous	
Instantaneous Unit.....	7	Unit - Pickup Test.....	20
C. Contact Ratings.....	8	5. High-Seismic Time-Target	
D. Ambient Temperature.....	9	Unit - Pickup and Dropout	
E. High-Potential Capability....	9	Test.....	21
F. Frequency.....	9	INSTALLATION PROCEDURE.....	22
CHARACTERISTICS.....	9	A. Introduction.....	22
A. Operating Principles.....	9	B. Surge-Ground and Relay-Case	
B. Operating Characteristics....	11	Ground Connections.....	22
1. Time-Overcurrent Unit.....	11	C. Test Plugs.....	22
a. Pickup and Time Delay..	11	D. Settings.....	23
b. Dropout and Reset Time.	13	1. Time-Overcurrent Unit.....	23
2. High-Seismic Instantaneous		a. Tap Setting.....	23
Overcurrent Unit (IOC)....	13	b. Time-Dial Setting.....	23
a. Pickup and Dropout....	13	2. High-Seismic Time-Target	
b. Transient Overreach....	13	Unit.....	24
c. Operating Time.....	13	3. High-Seismic Instantaneous-	
C. Burdens.....	14	Overcurrent Unit (IOC)....	25
CONSTRUCTION.....	15	E. Electrical Tests.....	25
A. General.....	15	PERIODIC CHECKS AND ROUTINE	
B. Time-Overcurrent Unit.....	15	MAINTENANCE.....	26
C. High-Seismic Instantaneous-		SERVICING.....	26
Overcurrent Unit (IOC).....	16	A. Time-Overcurrent Unit(TOC)....	26
D. High-Seismic Time-Target Unit	16	1. Pickup Calibration.....	26
E. Case.....	16	2. Operating Time Calibration.	26
RECEIVING, HANDLING AND STORAGE....	17	3. Printed Circuit Card.....	27
ACCEPTANCE TESTS.....	17	B. High-Seismic Instantaneous	
A. Visual Inspection.....	17	Unit (IOC).....	28
B. Mechanical Inspection.....	17	C. Contact Cleaning.....	28
C. Electrical Checks.....	18	RENEWAL PARTS.....	28
1. Drawout Relays, General... 18		LIST OF FIGURES.....	29

**STATIC TIME-OVERCURRENT RELAY
TYPE SFC**

DESCRIPTION

The Type SFC relays covered by these instructions are single-phase relays with a static time-overcurrent unit, and an optional hinged-armature-type instantaneous-overcurrent unit that provides instantaneous tripping at high-current levels. The instantaneous unit is of a design that has high seismic capability. Time-overcurrent relays are used extensively for the protection of utility and industrial distribution systems, and for overload back-up protection at other locations.

The SFC relay is available with the inverse, very inverse, or extremely inverse time-current characteristics shown in Figures 15,16,17. Both the time-overcurrent and instantaneous units are available with either one or two output contacts. These primary features are tabulated for the various SFC models in Table 1.

TABLE I

TYPE	TIME UNIT CHARACTERISTIC	FREQ.	HIGH-SEISMIC INSTANTANEOUS UNIT	CONTACT CIRCUITS	INTERNAL CONNECTIONS
SFC151A(#A)	Inverse	50/60	No	1	Figure 20
SFC151B(#A)	Inverse	50/60	Yes	1	Figure 21
SFC152A(#A)	Inverse	50/60	No	2	Figure 22
SFC152B(#A)	Inverse	50/60	Yes	2	Figure 23
SFC153A(#A)	Very Inverse	50/60	No	1	Figure 20
SFC153B(#A)	Very Inverse	50/60	Yes	1	Figure 21
SFC154A(#A)	Very Inverse	50/60	No	2	Figure 22
SFC154B(#A)	Very Inverse	50/60	Yes	2	Figure 23
SFC177A(#A)	Extremely Inverse	50/60	No	1	Figure 20
SFC177B(#A)	Extremely Inverse	50/60	Yes	1	Figure 21
SFC178A(#A)	Extremely Inverse	50/60	No	2	Figure 22
SFC178B(#A)	Extremely Inverse	50/60	Yes	2	Figure 23

#Refer to Table II to obtain form number that specifies pickup ranges.

These instructions do not purport to cover all details or variations in equipment nor to provide for every possible contingency to be met in connection with installation, operation or maintenance. Should further information be desired or should particular problems arise which are not covered sufficiently for the purchaser's purposes, the matter should be referred to the General Electric Company.

To the extent required the products described herein meet applicable ANSI, IEEE and NEMA standards; but no such assurance is given with respect to local codes and ordinances because they vary greatly.

TABLE II

FORM NO.	TIME-OVERCURRENT TAP RANGE-AMPERES	HIGH-SEISMIC INSTANTANEOUS PICKUP RANGE-AMPERES
1#	0.5 - 4	No Instantaneous
2#	1.5 - 12	No Instantaneous
3#	0.1 - 0.8	No Instantaneous
1##	0.5 - 4	0.5 - 4
2##	1.5 - 12	0.5 - 4
3##	0.5 - 4	2 - 16
4##	1.5 - 12	2 - 16
5##	0.5 - 4	10 - 80
6##	1.5 - 12	10 - 80
7##	0.5 - 4	20 - 160
8##	1.5 - 12	20 - 160

A Models
B Models

The time-overcurrent-unit tap is adjustable in steps of a fraction of an ampere of the current transformer (CT) secondary current, by setting the links in the current-tap block. The tap settings are as follows:

<u>TIME OVERCURRENT PICKUP RANGE</u>	<u>TAP-CURRENT SETTINGS</u>
0.1 - 0.8	From 0.1 to 0.8 amperes in 0.02 ampere steps
0.5 - 4	From 0.5 to 4 amperes in 0.1 ampere steps
1.5 - 12	From 1.5 to 12 amperes in 0.25 ampere steps

The instantaneous-overcurrent-unit pickup setting is continuously adjustable over an 8-to-1 range of current, as shown in Table II, by means of an adjustable core and a bifilar-wound operating-coil circuit. The operating-coil circuit is arranged so that the windings may be connected in either series or parallel. The series connection is used for the lower half of the 8-to-1 range and the parallel connection for the upper half. The adjustable core provides a 4-to-1 adjustment range for each coil connection. The instantaneous unit is of a design that has high seismic capability.

Both the time and instantaneous units have an 8-to-1 range of overcurrent tap adjustments, as shown in Table II. The fast reset and insignificant overtravel of the static time unit permits effective use of automatic reclosing in many applications. Because this unit is powered by the relay CT secondary current, the SFC does not require any DC control power.

Each SFC relay is equipped with a hand-reset electromechanical target in series with the time-unit contacts. This target is also of a design that has high seismic capability. A similar target is provided as a part of the instantaneous unit on those relay models that include the instantaneous unit. The SFC relay is mounted in the compact type VI case shown in Figure 27. Refer to OPERATING PRINCIPLES in the section titled **CHARACTERISTICS** for particular information on the relay operation.

APPLICATION

Time-overcurrent relays are used for the protection of feeders, transmission lines, alternating-current (C) machines and transformers, and for numerous other applications where accurate measurement of current and timing is necessary. The operating time of associated protective devices should be considered in the selection of a time-current characteristic for a particular application, to ensure proper coordination with a minimum of circuit isolation. Three basic time-current characteristics are available in Type SFC relays.

The Type SFC151 and SFC152 relays have the inverse-time-current characteristic shown in Figure 15. These relays are generally applied where the short-circuit-current magnitude is dependent largely upon the system generating capacity at the time of the fault.

The Type SFC153 and SFC154 relays have the very inverse-time-current characteristic shown in Figure 16. These relays are generally applied where the magnitude of short-circuit current flowing through any given relay is more dependent upon the relative location of the fault to the relay than on the system generation setup at the time of the fault.

The Type SFC177 and SFC178 relays have the extremely inverse-time-current characteristic shown in Figure 17. These relays are preferred for applications where sufficient time delay must be provided to allow a re-energized circuit to pick up an accumulated cold load without unnecessary tripping on inrush currents. Distribution-feeder circuits are a good example of such applications, and the extremely-inverse characteristic is best suited to such applications because it more nearly approximates typical power-fuse and fuse-cutout characteristics.

The general practice for grounded-distribution-system protection is to use a set of three relays for protection against interphase faults and a separate relay for single-phase-to-ground faults. The use of a separate ground relay is advantageous because it can generally be adjusted to provide faster and more sensitive protection for single-phase-to-ground faults than the phase relays can provide. Typical connections for such an application are shown in Figure 1.

The tap setting of the SFC time unit should be chosen so that it will operate for all short circuits in the protected zone, and also provide back-up protection for short circuits in the immediately-adjacent system element when possible. The time-unit tap should be set low enough to ensure that the minimum fault current is at least 1.5 times the tap setting.

The time-delay adjustment of the time unit should be chosen to assure selectivity with the protection on the adjacent system elements. This adjustment should be made for the condition that yields maximum fault current at the relay location. The time delay is determined by the adjacent relay operating time for this condition, plus a coordinating time allowance that includes the adjacent circuit-breaker maximum operating time and a safety factor to accommodate any uncertainties. Since the SFC time unit has insignificant overtravel, the only relay variation that needs consideration in the safety factor is the tolerance on the time curves. A 0.17-second safety factor is generally used if the relay time is determined by selecting a time dial setting from the time curves. This safety factor can be reduced to 0.07 second if the time unit is instead set to the desired time by accurate tests.

The static time unit has a maximum reset-before-trip time of 0.1 second when current is instantaneously reduced to 60% or less of tap setting. This fast-reset characteristic permits the use of multi-shot reclosing without a loss of selectivity due to "notching up".

The instantaneous-overcurrent unit can be applied in many instances to reduce the fault-clearing time for high fault currents. This unit is normally set to pick up only on internal faults in the protected zone. Significant transient overreach can be experienced under certain conditions, and this must be taken into account by selecting a pickup setting that is higher than that which would be dictated by the maximum steady-state external-fault current. The transient overreach characteristic for the instantaneous unit is shown in Figure 18.

RATINGS

A. TIME-OVERCURRENT UNIT

The time-overcurrent unit's continuous and one-second thermal ratings are shown in Table III.

TABLE III

TIME OVERCURRENT UNIT (TAP RANGE)	CONTINUOUS RATING AMPERES	ONE SECOND RATING AMPERES	K
0.1 to 0.8	1.0	150	22,500
0.5 to 4	4	150	22,500
1.5 to 12	12	340	115,000

The time-overcurrent-unit ratings apply for any current setting within the adjustment range. For times less than one second, the rating may be calculated according to the formula:

$$I = \sqrt{\frac{K}{T}}$$

where T is the time in seconds that the current is conducted.

In relays having an instantaneous overcurrent unit, the instantaneous operating coil is connected in series with the time-overcurrent-unit circuit. Thus, the overall circuit rating will be limited by either the time-overcurrent-unit rating or the instantaneous-current-unit rating, depending on which has the lowest current rating.

B. HIGH-SEISMIC INSTANTANEOUS UNIT

The instantaneous unit has a double-wound coil for operation on either of two ranges. Any setting obtained in the lower range (series connected) is doubled, within $\pm 5\%$, when the unit is connected for high-range operation (parallel connection).

The instantaneous unit has a continuous rating of 1.5 times the minimum setting or 25 amperes, whichever is smaller. Example: the 2.0-16.0 ampere instantaneous unit, when set on the low range (2.0-8.0 amperes) has a continuous rating of 3.0 amperes, and when connected for the high range (4-16 amperes) has a continuous rating of 6.0 amperes. The continuous and one-second current ratings for the instantaneous unit are shown in Table IV.

TABLE IV

HIGH-SEISMIC INSTANTANEOUS UNIT		SERIES OR PARALLEL	CONTINUOUS AMPERES	ONE-SECOND AMPERES	K
DESIGNATED RANGE	RANGE/ CONNECTIONS				
0.5 - 4.0	0.5 - 2.0	S	0.75	25	625
	1.0 - 4.0	P	1.5	50	2500
2.0 - 16.0	2.0 - 8.0	S	3.0	130	16900
	4.0 - 16.0	P	6.0	260	67600
10.0 - 80.0	10.0 - 40.0	S	15.0	400	160000
	20.0 - 80.0	P	25.0	600	360000
20.0 - 160.0	20.0 - 80.0	S	25.0	600	360000
	40.0 - 160.0	P	25.0	600	360000

Note: Higher current may be applied for shorter lengths of time in accordance with the formula:

$$I = \sqrt{\frac{K}{T}}$$

C. CONTACT RATINGS

All relay contacts will close and conduct up to 30 amperes momentarily for tripping duty at control voltages of 250 VDC or less. The current-conducting capability must also be limited by the ratings of the target-unit-operating-coil tap setting. Table V gives the target-current ratings as well as the resistance and impedance of the operating coil.

TABLE V

	TAP	
	0.2	2.0
DC COIL RESISTANCE \pm 10%	7	0.13
MINIMUM OPERATING (AMPERES)	0.15-0.20	1.5-2.0
)	0.3	3.0
CARRY 30 AMP FOR (SECONDS)	0.03	4.0
CARRY 10 AMP FOR (SECONDS)	0.25	30.0
60 HZ IMPEDANCE (OHMS)	52.0	0.53

If the tripping current exceeds 30 amperes, an auxiliary relay should be used whose connections are arranged so that the tripping current is not conducted through the contacts or the target coils of the protective relay.

Table VI gives the interrupting ratings for all relay contacts.

TABLE VI

VOLTS	AMPERES	
	INDUCTIVE +	NON-INDUCTIVE
AC 115	0.75	2.0
230	0.5	1.5
DC 48	1.0	3.0
125	0.5	1.5
250	0.25	1.0

+ The inductive rating is based on the inductance of an average trip coil.

D. AMBIENT TEMPERATURE

These relays are designed for use in ambient temperatures between -20° and $+55^{\circ}$ centigrade.

E. HIGH-POTENTIAL CABILITY

The relay will withstand a hipot of 1500 volts, 60 Hz rms, applied from all studs (except stud No. 8) to ground, and between the current and trip-circuit studs. Stud No. 8 is the surge ground and is tied to ground through the relay cradle and case.

F. FREQUENCY

The relay operates on an alternating sinewave current, 50-60 Hz.

CHARACTERISTICS

A. OPERATING PRINCIPLES

The SFC static time-overcurrent relay is shown in block-diagram form in Figure 2. Circuit details for each function are shown in Figures 3 through 11. Figures 12, 13, and 14 show the overall printed-circuit-card internal connections for the inverse, very-inverse, and extremely-inverse relay respectively. Figures 20, 21, 22, and 23 show the overall relay connections.

Referring to the block diagram of Figure 2, the protected-line CT secondary current (I) flows through three series-connected elements: The POWER SUPPLY, CT1, the SIGNAL SOURCE, CT2, and the optional instantaneous-overcurrent-trip unit, IOC. The POWER SUPPLY, CT1, feeds the power supply circuit, providing power to the printed-circuit card. The SIGNAL SOURCE, CT2, reduces the current, I , in a ratio of approximately 1000:1. The optional instantaneous-overcurrent-trip unit, IOC, is an electromechanical hinged-armature device providing instantaneous trip and target indication. It is of a design that has a high-seismic capability.

The reduced current from the SIGNAL SOURCE, CT2, is made unidirectional and converted proportionally to a voltage, e_i , by the RECTIFIER AND TAP RESISTOR circuit. The proportionality constant is selected by the setting on the Current Tap Block. " e_i " is the quantity that the relay measures.

The PICKUP LEVEL DETECTOR is used as a permissive device to tell the timing circuitry when to begin timing. The state of the relay (either picked up or not picked up) is transmitted to the the timing circuitry by e_o .

The FUNCTION GENERATOR is a wave-shaping circuit that shapes e_i to give the desired inverse, very-inverse, or extremely-inverse characteristic. The shaped wave is e_f .

The TIME DIAL, LINEAR-RAMP GENERATOR and LEVEL DETECTOR together constitute the time circuitry. They measure e_o to determine whether to begin timing or to reset. When e_o switches to its picked-up state, the determination of how long to wait before giving a trip signal, e_t , is accomplished by integrating e_f .

When the timing circuitry "times out", the trip signal, e_t , closes the Time Overcurrent Unit (TOC) telephone-type relay via the OUTPUT CIRCUIT. Trip-circuit current energizes the TIME TARGET to give a target indication.

The description that follows gives more circuit details:

1. The output voltage, e_i , of the RECTIFIER AND TAP RESISTORS is a unidirectional voltage that is proportional to the relay input current, I . The circuit shown in Figure 3 illustrates how the signal level for a given current level can be adjusted in desired steps by paralleling precision resistors in the current-tap block.
2. A PICKUP LEVEL DETECTOR circuit monitors input signal e_i and determines at what level of relay-input current I the relay should provide time-delay tripping output. The circuit is shown in Figure 4, where amplifier IC1A functions as a voltage comparator and switches from a positive to a negative saturated state when the reference bias is exceeded. Feedback capacitor C7 is selected so that positive switching action occurs when the average bias from e_i just exceeds this reference bias. A potentiometer, R27, is provided for factory adjustment of the pickup level.
3. The FUNCTION GENERATOR for obtaining the inverse, very inverse, or extremely inverse characteristic is shown in Figures 5, 6, and 7 respectively. In Figures 5 and 6, a single operational amplifier is used with a combination of diodes, zener diodes, bias levels, and a feedback network to produce the required piecewise linear-gain characteristic for the input voltage level. In Figure 7, an additional operational amplifier in the feedback network is required for the desired increasing-gain characteristic.

The characteristic of each FUNCTION GENERATOR is shown in the plot (at the right) of output voltage e_f versus input voltage e_i . The input and output waveforms of e_i and e_f versus time are shown, at the top.

4. The LINEAR RAMP GENERATOR shown in Figure 8 is a simple integrator circuit that integrates the output signal, e_f , from the FUNCTION GENERATOR. Ten discrete resistors inserted in steps, and the time-dial vernier covering one of these steps, provide ten integrating time constants with vernier control over each step for field adjustment. This adjustment is the Time-Dial Setting.
5. A LEVEL DETECTOR consisting of operational amplifier IC1B is used as a voltage comparator as shown in Figure 9. A negative bias on the inverting input terminal keeps the output clamped at approximately -0.7 volts by means of a feedback diode, D21. When the output voltage of the linear ramp generator, e_r , produces a positive bias condition that exceeds the negative bias, the operational amplifier, IC1B, will switch to a negative saturation level. This switching action establishes that the integration voltage level, e_r , has exceeded the trip voltage level. A factory-adjusted potentiometer, R45, is used to adjust this level precisely.
6. The OUTPUT CIRCUIT and relay TOC shown in Figure 10 are used to close the trip circuit contacts. The negative-output signal from the LEVEL DETECTOR biases transistor Q1 into a saturated "ON" state and energizes the TOC telephone-type relay. A diode placed across the relay coil shunts the inductive energy and prevents a surge voltage across the transistor when it is switched into a blocking state.

7. The POWER SUPPLY shown in Figure 11 obtains its power from POWER SUPPLY CT1. On each half cycle, the rectified secondary current from this current transformer charges filter capacitor C₃ until its voltage exceeds the zener diode (D₅) level, which gates the Silicon-Controlled Rectifier (SCR). When gated from this voltage-sensing circuit, SCR crowbars the output of the current transformer until the input current, I, reaches its current zero (0) and a non-conducting state is re-established. Under steady-state conditions, the CT1 secondary current supplies the energy lost by the filter capacitor, on a half cycle basis, with the SCR conducting for the greatest portion of time. Regulated ± 15 volts and ± 5.1 volts for the electronic circuit is obtained from series zener diodes D₇-D₁₀ and a resistor, R₃, across the filter capacitor.

B. OPERATING CHARACTERISTICS

1. Time-Overcurrent Unit

a. Pickup and Time Delay

Pickup of the time-overcurrent unit is the minimum input AC current required for the unit to sense a steady-state overcurrent condition and close its output contacts after a time-delay operation. This is accurate to $\pm 3\%$ of tap setting at 25°C, $\pm 6\%$ over the entire ambient temperature range of -20 to +55°C.

The operating time required for the time-overcurrent unit to close its output contacts, when a given multiple of current level above its tap setting is suddenly applied to the relay, defines its time-current characteristic. Figures 15, 16, and 17 illustrate the time-current characteristic for the inverse, very-inverse, and extremely-inverse time-overcurrent units respectively.

Curves are shown for the integer time-dial settings where the time-dial vernier adjustment is set at zero. The time-dial vernier may be used to set the unit's characteristic between the curves for specific integers.

At an ambient temperature of 25°C the time-overcurrent unit will meet the published time-current characteristic curve for any integer setting within the tolerances given in Table VII. Percentages are percent of published time-current value. "Time In Seconds" operating value is shown in Figures 15, 16, or 17.

TABLE VII

SFC RELAY	CHARACTERISTIC	TOLERANCE AT MULTIPLES OF RELAY TAP SETTING AT 25°C		
		1.1-2	2-20	20-50
151 152	Inverse	$\pm 15\%$	$\pm 7\%$ or 20 ms. whichever greater	$\pm 7\%$ or 20 ms. whichever greater
153 154	Very Inverse	$\pm 15\%$	$\pm 7\%$ or 10 ms. whichever greater	$\pm 7\%$ or 10 ms. whichever greater
177 178	Extremely Inverse	$\pm 17\%$	$\pm 10\%$ or 10 ms. whichever greater	$\pm 10\%$ or 10ms. whichever greater

Over an ambient temperature range of -20 to $+55^{\circ}\text{C}$, a unit's operating time will vary from its 25°C ambient operating time within the tolerances give in Table VIII. Percentages are percent of the 25°C ambient operating time for a given relay.

TABLE VIII

SFC RELAY	CHARACTERISTIC	TOLERANCE AT MULTIPLES OF RELAY TAP SETTING, OVER -20° to $+55^{\circ}\text{C}$ RANGE		
		1.1-2	2-20	20-50
151 152	Inverse	$\pm 8\%$	$\pm 5\%$	$\pm 5\%$
153 154	Very Inverse	$\pm 8\%$	$\pm 5\%$	$\pm 5\%$
177 178	Extremely Inverse	$\pm 10\%$	$\pm 8\%$	$\pm 6\%$

b. Dropout and Reset Time

Dropout of the time-overcurrent unit is the maximum input AC current required for the relay to sense a steady-state current-below-pickup condition and open its contacts. Dropout-to-pickup ratio is 93% or more.

Reset-before-trip time of the time-overcurrent unit will not exceed 100 ms. when current is reduced to 60% or less of tap setting.

2. High-Seismic Instantaneous-Overcurrent Unit (IOC)

a. Pickup and Dropout

The instantaneous-overcurrent unit used in these relays is adjustable over an 8-to-1 range of pickup current by means of a two-winding operating coil and an adjustable core. Pickup current is the current at which the unit will close its contacts with gradually-increasing current applied to the operating coil. Dropout current is the current at which the unit will open its contacts when applied current is gradually reduced from a level above pickup. The IOC units will drop out at approximately 50% or more of the pickup setting.

b. Transient Overreach

The current in the primary of the current transformer can have considerable offset, depending on the parameter of the power circuit. The overreach for the IOC unit under worst-case conditions is shown in Figure 18 for various system angles at the minimum and maximum pickup calibration.

c. Operating Time

The operating time of the IOC unit is shown in Figure 19 as a function of the multiples of pickup current.

C. BURDENS

Burdens for the time-overcurrent unit are listed in Table IX. Burdens decrease with increasing current above minimum tap, due to SCR shunting in the power supply circuit. Since the power supply is the major portion of the burden, the burden for a given input current will be constant, irrespective of tap setting.

TABLE IX

TAP RANGE AMPS	HZ	MINIMUM TAP AMPS	BURDEN AT MINIMUM TAP						
			R	jX	Z	3 TIMES	10 TIMES	20 TIMES	
0.1/0.8	60	0.1	46	154	160	37	10	8	
0.5/4	60	0.5	1.85	6.15	6.42	1.5	0.42	0.31	
1.5/12	60	1.5	0.72	0	0.72	0.174	0.046	0.033	

Burdens for the high-seismic instantaneous unit are listed in Table X.

TABLE X

RANGE 60 HZ RELAYS ONLY (AMPS)	+	BURDENS AT				BURDENS IN OHMS(Z)			VA AT 5 AMPS CALCULATED FROM IMPEDANCE AT MIN PICKUP (I ² Z)
		MIN. TAP AMPS	MIN. R OHMS	MIN. PICKUP J _X OHMS	MIN. Z OHMS	3 TIMES PICKUP	10 TIMES PICKUP	20 TIMES PICKUP	
0.5-4.0	LOW	0.5	10.3	8.1	12.9	12.9	12.9	12.9	325.5
	HIGH	1.0	2.6	2.02	3.31	3.31	3.31	3.31	82.75
2.0-16.0	LOW	2.0	0.72	0.88	1.13	1.13	1.13	1.13	22.50
	HIGH	4.0	0.18	0.22	0.284	0.284	0.284	0.284	7.10
10.0-80.0	LOW	10.0	0.04	0.05	0.064	0.064	0.064	0.064	1.60
	HIGH	20.0	0.01	0.012	0.0156	0.0156	0.0156	0.0156	0.39
20.0-160.0	LOW	20.0	0.02	0.03	0.036	0.036	0.036	0.036	0.90
	HIGH	40.0	0.005	0.0008	0.009	0.009	0.009	0.009	0.225

+Low means two windings connected in series.
 High means two windings connected in parallel.
 See internal connections diagram for additional information
 The instantaneous burdens are approximately 10% lower at 50 Hz.

CONSTRUCTION

A. GENERAL

The SFC static overcurrent relays consist of a static time-overcurrent unit, a target unit, and an instantaneous unit when specified. The relays are available with either a single contact or double contacts. Each of the relays is mounted in a small, single-ended drawout (V1) case. The internal-connections diagrams for the various models are identified in Table XI.

Figures 25 and 26 show the front and rear views of an SFC relay, with the relay removed from its case.

TABLE XI

SFC	INTERNAL CONNECTION DIAGRAM
Without instantaneous, with a single contact	Figure 20
Without instantaneous, with double contacts	Figure 22
With instantaneous and a single contact	Figure 21
With instantaneous and double contacts	Figure 23

B. TIME-OVERCURRENT UNIT

The time-overcurrent units consist of a printed-circuit card, a signal-source current transformer, a power-supply current transformer, and a telephone-type-relay output unit. here are also two electronic components that are not on the printed-circuit card. These are an Silicon-Control Rectifier, SCR that is associated with the power supply, and the time-dial vernier potentiometer. All components are mounted in a steel framework called the cradle.

The printed-circuit card is mounted near the top of the relay. The signal-source current transformer (CT2) is the torroidal-type transformer that is mounted on the back of the plate in the rear of the relay. The power-supply transformer (CT1) is mounted in the center of the relay between the front and back plates. The telephone-type relay (TOC) is mounted with its contacts and armature projecting through the back plate in the rear of the relay. The Silicon-Control Rectifier, SCR is mounted on the relay back plate and the time-dial vernier is mounted in the center of the front of the relay on the nameplate.

The three adjustments used in setting the time-overcurrent unit are the current tap block, the time dial, and the time-dial potentiometer. These adjustments are on the front of the relay and can be seen in Figure 25. See the section titled **SETTINGS** in the **INSTALLATION PROCEDURE** section for further details.

C. HIGH-SEISMIC INSTANTANEOUS-OVERCURRENT UNIT (IOC)

The instantaneous unit is used on certain SFC relay models to provide instantaneous tripping for current exceeding a predetermined value.

The instantaneous unit is a small hinged-armature type unit that is mounted on the right front side of the relay (see Figure 25). Its contacts are normally connected in parallel with the contacts of the main time-overcurrent unit. Its coil is connected in series with the current-actuating circuit of the time-overcurrent unit. This unit is of a design that has a high seismic capability.

When the current reaches a predetermined value the instantaneous unit operates, closing the contact circuit and raising its target into view. The target latches in the exposed position until released by pressing the button beneath the lower left-hand corner of the relay cover.

The instantaneous unit is adjustable over an 8-to-1 range of pickup current by means of an adjustable core and an arrangement that allows coil connections to be changed. The coil is a bifilar wound coil. The coil leads may be wired either in series or in parallel by changing the connections on the terminals on the back of the relay cradle block (see Figures 21 and 23).

D. HIGH-SEISMIC TIME-TARGET UNIT

The target is a small hinged-armature unit mounted on the left-hand side of the front relay. This unit has its operating coil in series with the TOC unit contacts. When the target unit operates, it raises its target flag into view. The target flag latches in the exposed position until released by pressing the reset button in the lower left-hand corner of the relay cover. The target unit has no contacts. This unit is of a design that has a high seismic capability.

The operating coil of the target is tapped. The tap plate for the target is on the front of the time unit in the lower right-hand corner. The tap plate is engraved showing the tap ratings of the unit and proper tap screw positions for the tap setting.

E. CASE

The components of each relay are mounted on a cradle assembly that can be easily removed from the relay case. The cradle is locked in the case by means of a latch at the bottom. The electrical connections between the case blocks and cradle blocks are completed through removable connection plugs. Separate testing plugs can be inserted in place of the connection plugs to permit testing the relay in its case. The cover is attached to the front of the case and includes an interlock arm that prevents the cover from being replaced until the connection plug has been inserted.

The case is suitable for either semiflush or surface mounting on panels up to two inches thick. Hardware is available for all panel thicknesses up to two inches, but panel thickness must be specified on the order to ensure that the proper hardware will be provided. Outline and panel-drilling dimensions are shown in Figure 27.

RECEIVING, HANDLING AND STORAGE

These relays, when not included as a part of a control panel, will be shipped in cartons designed to protect them against damage. Immediately upon receipt of a relay, examine it for any damage sustained in transit. If injury or damage resulting from rough handling is evident, file a damage claim at once with the transportation company and promptly notify the nearest General Electric Sales Office.

Reasonable care should be exercised in unpacking the relay in order that none of the parts are injured, nor the adjustments disturbed.

If the relays are not to be installed immediately, they should be stored in their original cartons in a place that is free from moisture, dust, and metallic chips. Foreign matter collected on the outside of the case may find its way inside when the cover is removed and cause trouble in the operation of the relay.

ACCEPTANCE TESTS

Immediately upon receipt of the relay, an INSPECTION AND ACCEPTANCE TEST should be made to make sure that no damage has been sustained in shipment and that the relay calibrations have not been disturbed. If the examination or test indicates that readjustment is necessary, refer to the section on **SERVICING**.

These tests may be performed as part of the installation or the acceptance tests, at the discretion of the user. Since most operating companies use different procedures for acceptance and for installation tests, the following section includes all applicable tests that may be performed on these relays.

A. VISUAL INSPECTION

Check the nameplate stamping to make sure that the model number and rating of the relay agree with Table 1 and the requisition.

Remove the relay from its case and check that there are no broken or cracked molded parts or other signs of physical damage, and that all the screws are tight.

B. MECHANICAL INSPECTION

1. The armature of the high-seismic time-target unit, as well as the armature and contacts of the high-seismic instantaneous unit, should move freely when operated by hand. There should be at least 0.015-inch wiper on the instantaneous-unit contacts. Check this by inserting a 0.010-inch feeler gage between the front half of the shaded pole and the armature, with the armature held closed. Contacts should close with the feeler gage in place.
2. The targets in the time-target unit and in the instantaneous unit must come into view and latch when the armatures are operated by hand, and should unlatch when the target-release lever is operated.

3. The telephone-relay unit (TOC) used in these relays should be checked to have a contact gap of at least 15 mils (0.015 inch), contact wipe of 5 mils, and residual of 2 mils or more. The contact wipe may be checked by inserting a 5 mil shim between the armature residual screw and pole piece and operating the armature by hand. The normally-open contacts should make contact with the shim in place when the armature is operated manually. The "residual" is the distance the residual screw projects through the armature.
4. Make sure that the fingers and shorting bars agree with the internal-connections diagram.

Caution

Every Circuit In The Drawout Case Has An Auxillary Brush. It Is Especially Important On Current Circuits And Other Circuits With Shorting Bars That The Auxiliary Brush Be Bent High Enough To Engage The Connection Plug Or Test Plug Before The Main Brushes Do. This Will Prevent CT Secondary Circuits From Being Opened. See Figure 28.

C. ELECTRICAL CHECKS

1. Drawout Relays, General

A relay may be tested without removing it from the panel by using a 12XLA13A test plug. This plug makes connections only with the relay, and does not disturb any shorting bars in the case. Of course, the 12XLA12A test plug may also be used. Although this test plug allows greater testing flexibility, it also requires CT shorting jumpers and the exercise of greater care, since connections are made to both the relay and the external circuitry.

The SFC relay does not require in-case testing. Therefore, it may be advantageous at certain locations to remove the relay from its case for testing.

2. Power Requirements, General

All alternating-current-operated devices (AC) are affected by frequency. Since non-sinusoidal waveforms can be analyzed as a fundamental frequency plus harmonics of the fundamental frequency, it follows that AC devices (relays) will be affected by the applied waveform.

Therefore, in order to test AC relays properly, it is essential to use a sine wave of current and/or voltage. The purity of the sine wave (i.e. its freedom from harmonics) cannot be expressed as a finite number for any particular relay; however, any relay using tuned circuits, RL or RC networks, or saturating electromagnets (such as time-overcurrent relays) would be especially affected by non-sinusoidal waveforms.

This relay responds to the input-current waveform in a different manner than most AC ammeters. Therefore, if the test source contains high-amplitude harmonics, the ammeter and relay responses will be different. The relay has been calibrated using a conventional 60 Hz shop source, of minimum harmonic content. It should be tested with a similar current source of sinusoidal waveform, essentially free from harmonics.

The ammeter and times used to establish pickup and time-delay characteristics must be calibrated and have accuracies that are considerably better than the accuracy of the relay. In addition, power sources must remain very stable for these tests, especially during pickup and timing tests near the pickup level.

To minimize the effects of the non-linear impedances of the relay power supply, the current source should be an adjustable resistor (loadbox) in series with a 120 volt (or greater) 50/60 Hz power source.

It should be noted that the degree of test accuracy depends on the power source and instrumentation utilized. Functional tests performed with incorrect power supplies and instruments are useful merely to make sure that the relay is functioning properly and its characteristics are **approximately** verified. However, recalibration of a relay under these conditions will not produce an accuracy that is any better than the test system, and could result in characteristics outside of the tolerances as specified.

If examination or Tests 3-5 below, indicate readjustment is necessary, refer to the section titled **SERVICING**.

3. Time-Overcurrent Unit

a. Pickup Calibration Check

- 1) Connect the relay as shown in Figure 24. Use a source of 120 volts rms or more, at rated frequency, with current limited by resistive load, to supply operating current to the relay. Current should be stable to within $\pm 1\%$ of set level.
- 2) Set the time dial at Number 1 and the time-dial vernier fully counterclockwise. Set the current tap block for a tap setting of 0.1 amperes for the 0.1/0.8 amp relay, 0.5 ampere for the 0.5/4 amp relay or 1.5 amperes for the 1.5/12 amp relay.
- 3) Connect a continuity-indicating lamp to Studs 1-2. When lamp is lit, relay is picked up.
- 4) Apply current **gradually** to the relay. Start with a current below the set tap and use the loadbox to increase the current applied to the relay. Gradually increase current to 5% below tap setting. The relay should NOT pick up for at least one (1) minute. Gradually increase current to 5% above tap setting. The relay should pick up in no more than half a minute.

This same procedure may be used to check pickup at other tap-block settings.

b. Time Calibration Check

- 1) Connect the relay as for the pickup calibration check, except a switch is needed so that current may be suddenly applied to the relay. The timer should be arranged so that application of current to the relay starts the timer, and trip-circuit-contact closure stops the timer. See Figure 24.
- 2) Set the time-dial vernier potentiometer fully counterclockwise. Set the time-dial selector switch (on the printed circuit card) to the detent at Number 5.
- 3) Set the current tap block at 0.1 amp for the 0.1/0.8 amp relay, 0.5 amp for the 0.5/4 amp relay or 1.5 amps for the 1.5/12 amp relay.
- 4) Set the loadbox to deliver five (5) times pickup setting to the relay (0.5, 2.5 or 7.5 amperes).
- 5) **Suddenly** apply current to the relay. The time required for the TOC unit to close its contacts should be as follows:

Inverse	1.39 Sec. \pm .07
Very Inverse	1.10 sec. \pm .06
Extremely Inverse	0.57 sec. \pm .03

- 6) This procedure may be used to check the relay-operating time at other multiples of tap setting or other time-dial settings. The time-current curve for the time-overcurrent unit is shown in Figure 15, 16 or 17, depending on the relay being tested.

Note that the time-dial vernier potentiometer must be **fully counterclockwise** for the relays to fall on the published time-dial curves.

The operating time of the relays should agree with the published curve in accordance with the tolerances of Table VII.

4. High-Seismic Instantaneous Unit - Pickup Test

Make sure that the instantaneous unit is wired for the range it is to operate (see internal connection diagram, Figures 20-23) and connected as indicated on the test circuit, Figure 24. Whenever possible, use the higher range (parallel connection) since the higher range has a higher continuous rating.

Before applying current, the unit must be set as follows (see Figure 25). Loosen the locknut and turn the pole piece toward the desired setting. (Turning the adjustable pole piece up increases the pickup, turning the pole piece down decreases the pickup). Bring up the current slowly until the unit picks up. It may be necessary to repeat this operation until the desired pickup value is obtained. Once the desired pickup value is reached, tighten the locknut and retest.

Caution

The Instantaneous Unit Is Rated 1.5 Times Minimum Pickup Continuously. Do Not Leave The Current On Too Long, As It May Damage The Unit.

With the unit connected for low-range operation (series connection) and the target in the "Down" position, check the pickup at the minimum calibration mark. The pickup should be within the limits in Table XII.

TABLE XII

UNIT RANGE AMPERES	MINIMUM AMPERES	CALIBRATION AMPERES	MAXIMUM AMPERES
0.5 - 4.0	0.45	0.5	0.55
2.0 - 16.0	1.8	2.0	.2
10.0 - 80.0	9.0	10.0	11.0
20.0 - 160.0	18.0	20.0	22.0

5. High-Seismic Time-Target Unit - Pickup and Dropout Test

The procedure for testing pickup and dropout is as follows. Refer to the **SETTINGS** section for the method of changing taps.

- 1) Connect relay studs 1 and 2 (see Figures 20, 21, 22, 23) to a DC source, ammeter and load box so that the current can be controlled over a range of 0.1 to 2.0 amperes.
- 2) Block the telephone relay (TOC) closed. Reset the target in the "Down" position.
- 3) Increase the current slowly until the target unit picks up. Lower the current until the unit drops out. Pickup and dropout should be within the limits of Table XIII.

TABLE XIII

TAP	PICKUP CURRENT	DROPOUT CURRENT
0.2	0.15-0.195	.05 or more
2.0	1.50-1.95	.50 or more

4) When tests are complete, BE SURE to unblock the telephone relay (TOC).

INSTALLATION PROCEDURE

A. INTRODUCTION

The location should be clean and dry, free from dust and excessive vibration, and well lighted to facilitate inspection and testing.

The relay should be mounted on a vertical surface. The outline and panel diagram is shown in Figure 27.

The internal-connections diagrams for the various types of relays are shown in Figures 20, 21, 22, and 23. If examination or test indicates readjustment is necessary, refer to the section titled **SERVICING**.

B. SURGE-GROUND AND RELAY-CASE-GROUND CONNECTIONS

One of the mounting studs or screws should be permanently connected to ground by a conductor not less than No. 12 B&S gage copper wire or its equivalent. This connection is made in order to ground the relay case. In addition, the terminal designated as "surge ground" on the internal-connection diagram must be tied to ground for the surge-suppression networks in the relay to perform properly. This surge-ground lead should be as short as possible to ensure maximum protection from surges (preferably 10 inches or less to reach a solid ground connection).

C. TEST PLUGS

The relay may be tested without removing it from the panel by using a 12XLA13A test plug. This plug makes connections only with the relay, and does not disturb any shorting bars in the case. Of course, the 12XLA12A test plug may also be used. Although this test plug allow greater testing flexibility, it also requires CT shorting jumpers and the exercise of greater care, since connections are made to both the relay and the external circuitry. Additional information on the XLA test plugs may be obtained from GEI-25372.

D. SETTINGS

The three adjustments used in setting the time-overcurrent unit are the current tap block, the time dial, and the time-dial vernier potentiometer. These adjustments are on the front of the relay and can be seen in Figure 25.

1. Time-Overcurrent Unita. Tap Setting

The minimum current at which the relay will close its contacts is determined by the setting of the links in the current tap block. This tap block is on the end, toward the front center, of the printed circuit card. The tap block is arranged (see Figure 23) so that the tap setting of the relay is additive; that is, the tap setting is equal to the minimum tap in the range of the relay plus the sum of the weights of each of the links that is in the "in" position. The weight of each link is given on the tap plate directly below the tap-block assembly.

Links that show their broad sides when viewed from the front of the relay are in the "in" position and influence the tap setting of the time unit. Links that are seen edgewise from the front of the relay are "out" and have no influence on the tap setting.

EXAMPLE OF SETTING: For example, if it were desired to set a 0.5/4 amp relay at a tap of 2.80 amps, the 1.5, 0.5, 0.2, and 0.1 amp links would be set in the "in" position. All other links would be set to be "out". As indicated on the tap plate, the setting of the relay would be the minimum tap (0.5 amps for a 0.5/4 amp relay) plus the sum of the weights of the links in the "in" position. This is $0.5 + 1.5 + 0.5 + 0.2 + 0.1$, or 2.80 amperes. The 1.5/12 amp relay pictured in Figure 25 is set for a tap of 3.0 degrees ($1.5 + 0.5 + 1.0$).

b. Time-Dial Setting

The relay has two time-dial adjustments, a time dial and a time-dial vernier. The time dial is a rotary switch mounted on the front right-hand side of the printed-circuit card. The rotary switch has positions labelled 1 through 10 corresponding to the time-dial settings shown on the time-current curves of Figures 15-17. The rotary switch should be set so the dot on the base lines up with the desired time number. The switch has a detent mechanism to aid in setting it; however, the detent is not positive and care should be taken to make sure that the time dial is not left between click stops; otherwise, the relay will be at the 10 time-dial setting.

The time-dial vernier is a potentiometer that is mounted on the front of the relay in the center of the nameplate. This vernier may be used to set the relay between integer time-dial curves. The vernier setting adds to the integer time-dial setting of the time-dial switch. The fully counterclockwise position corresponds to a time-dial vernier setting factor of 0. There are two stamped marks in the nameplate for setting factors 0.5 and 1.0. Intermediate setting factors are interpolated. See Figure 25.

Approximate operating times for the time-dial vernier settings other than 0 are determined as follows:

$$T = T_D + K_S (T_{D+1} - T_D)$$

Where

- T = Approximate Operating time
- K_S = Time-dial vernier setting factor
- T_D = Operating time for Given Integer Time-dial setting at Given Multiple
- T_{D+1} = Operating Time for Next Higher Integer time-dial Setting at Given Multiple
- 1 ≤ D < 10 = Integer Time-dial Setting

EXAMPLE: Refer to Figure 15. For an integer time-dial setting of 2, indicated position of vernier potentiometer = 0.4, and 5 multiples of tap applied, the time of operation is

$$\begin{aligned} T &= T_D + K_S (T_{D+1} - T_D) \\ &= T_2 + 0.4 (T_3 - T_2) \\ &= 0.535 + 0.4 (0.825 - 0.535) \\ &= 0.651 \text{ sec.} \end{aligned}$$

It should be emphasized that the time-dial vernier must be set fully counterclockwise for the relay operating characteristic to be one of the integer time-dial curves shown in Figures 15, 16, and 17.

The two factory adjustments are the pickup-calibration potentiometer and the time-calibration potentiometer. These are small adjustable potentiometers mounted on the front left of the printed-circuit card.

These potentiometers are not employed in setting the relay; however, they may be used to recalibrate the relay as outlined in the **SERVICING** section.

The pickup-calibration potentiometer is the potentiometer that is farthest to the left when the relay is viewed from the front. The time-dial calibration potentiometer is to the right of it, towards the time dial (see Figure 25).

2. High-Seismic Time-Target Unit

The time-target unit has an operating coil that has two taps. The relay is shipped from the factory with the tap screw in the lower-ampere position. The tap screw is the screw holding the right-hand stationary plate. To change the tap setting, first remove one screw from the left-hand stationary plate and place it in the desired tap. Next, remove the screw from the undesired tap and place it on the left-hand stationary plate where the first screw was removed. See Figure 25. This procedure is necessary to prevent the right-hand stationary plate from getting out of adjustment. Screws should **never** be left in **both** taps at the same time.

3. High-Seismic Instantaneous-Overcurrent Unit (IOC)

The instantaneous unit is adjustable over an 8-to-1 range of pickup current by means of an adjustable core and an arrangement that allows coil connections to be changed. The coil is a bifilar wound coil. The coil leads may be wired either in series or in parallel by changing the connections on the terminals on the back of the relay cradle block (see Figures 21 and 23).

The adjustable core provides a 4-to-1 range of pickup adjustment. The core is adjusted by loosening the locknut (see Figure 25) and turning the core. Turning the core counterclockwise (viewed from the top) increases pickup. Changing the coil connections from series to parallel doubles the pickup for a given core setting (see Figures 21 and 23). Where the ranges overlap, use the parallel connection since it has a higher continuous rating.

E. ELECTRICAL TESTS

A field test should be made at the site of installation to be sure that the time-overcurrent unit, the instantaneous-overcurrent unit and the time-target unit are calibrated to meet the desired field settings. It is recommended that the procedure outline in **ELECTRICAL CHECKS** under **ACCEPTANCE TESTS** be followed to check the specific settings that are required when the relay is in service. If examination or test indicates that readjustment is necessary, refer to the section on **SERVICING**.

PERIODIC CHECKS AND ROUTINE MAINTENANCE

In view of the vital role of protective relays in the operation of a power system, it is important that a periodic test program be followed. It is recognized that the interval between periodic checks will vary depending upon environment, type of relay, and the user's experience with periodic testing. Until the user has accumulated enough experience to select the test interval best suited to his individual requirements, it is suggested that the points listed under ACCEPTANCE TESTS be checked at an interval of from one to two years. See SERVICING section for contact cleaning.

SERVICING

CAUTION

Remove ALL power from the relay before removing or inserting any of the printed-circuit boards. Failure to observe this caution may result in damage to and/or misoperation of the relay.

A. TIME-OVERCURRENT UNIT (TOC)

If it is found during testing that the time-overcurrent unit is out of limits (be sure power source and instrumentation are those specified in the section titled ACCEPTANCE TESTS, the unit may be recalibrated as follows:

1. Pickup Calibration

- 1) Connect the relay as shown in Figure 24. Use a source of 120 volts rms or more at rated frequency, with current limited by a series resistor. This is the current supply to the relay and must be stable to within $\pm 1/2\%$ of set point.
- 2) Set the time dial (on the printed-circuit card) on Number 1 and the time-dial vernier on 0 (fully counterclockwise). Set the pluggable connectors on the current tap block for a tap setting of 0.1 for the 0.1/0.8 amp unit, 0.5 for the 0.5/4 amp unit or 1.5 amp for the 1.5/12 amp unit (none of the link broad sides should show from the front of the unit).
- 3) Gradually increase the current from 0 to 5% below tap setting. Leave the current at this level for 30 seconds; the continuity-indicating light should not light, showing that the relay has not picked up.
- 4) Increase the current to 5% above tap setting. The relay should pick up in 30 seconds or less.
- 5) If the procedure of steps 3-4 is not possible, the pickup of the relay may be changed by adjusting the pickup-calibration potentiometer (small 20-turn potentiometer on front of printed-circuit card farthest to left, see Figure 25). Note that clockwise turning increases relay pickup.
- 6) After adjusting the potentiometer, repeat steps 3 and 4 above until no further adjustment is necessary.

- 7) The calibration of other tap settings may be checked following steps 3-4, at the user's discretion.

2. Operating Time Calibration

- 1) Connect relay as in Figure 24, using a switch so that current may be suddenly applied. The timer should be arranged so that application of current to the relay starts the timer, and trip-circuit contact-closure stops the timer.
- 2) The time-dial vernier potentiometer must be set fully counterclockwise on 0. Set the time-dial switch to Number 5.
- 3) Set the current tap block to 0.1 amp for the 0.1/0.8 amp relay, 0.5 amp for the 0.5/4 amp relay or 1.5 amp for the 1.5/12 amp relay.
- 4) Set the current to deliver five (5) times tap setting (0.5, 2.5 or 7.5amperes).
- 5) **Suddenly** apply current to the relay and measure trip time. The times for a specified characteristic should be as follows:

1.39 ± 5% seconds for inverse
 1.10 ± 5% seconds for very-inverse
 0.57 ± 5% seconds for extremely-inverse

To adjust trip time, the time-calibration potentiometer (second 20-turnpotentiometer from left, viewing printed-circuit board from front - see Figure 25) is turned clockwise for more time and counterclockwise for less time.

Note that the time-dial vernier potentiometer must be turned **fully counterclockwise** for the relay to have an integer time-dial setting as published in the time curves.

3. Printed-Circuit Card

Should a printed-circuit card become inoperative, it is recommended that this card be replaced with a spare. In most instances, the user will be anxious to return the equipment to service as soon as possible and the insertion of a spare card represents the most expeditious means of accomplishing this. The faulty card can then be returned to the factory for repair or replacement.

Although it is not generally recommended, it is possible with the proper equipment and trained personnel to repair cards in the field. (See CAUTION on next page) This means that a troubleshooting program must isolate the specific component on the card that has failed. By referring to the internal-connections diagram for the card, it is possible to trace through the card circuit by signal checking, to determine which component has failed. This, however, may be time consuming and if the card is being checked in place in its unit, as is recommended, will extend the outage time of the equipment.

Caution

Great care must be taken in replacing components on the cards. Special soldering equipment suitable for use on the delicate solid state components must be used and, even then, care must be taken not to cause thermal damage to the components, and not to damage or bridge over the printed-circuit buses. The repaired area must be re-covered with a suitable high-dielectric plastic coating, to prevent possible breakdowns across the printed circuit buses due to moisture or dust.

B. HIGH-SEISMIC INSTANTANEOUS UNIT (IOC)

1. Both contacts should close at the same time.
2. The backing strip should be so formed that the forked end (front) bears against the molded strip under the armature.
3. With the armature against the pole piece, the cross member of the "T" spring should be in a horizontal plane and there should be at least 0.015 inch wiper on the contacts. Check this with the armature held closed, by inserting a 0.010 inch feeler gage between the front half of the shaded pole and the armature. Contacts should close with the feeler gage in place.
4. Should the unit's wiper be out of adjustment, the wiper may be readjusted by loosening the mounting screws clamping the left and right stationary contact plates. Raise the armature against a 0.010 inch gage between the front half of the shaded pole and the armature. Adjust the stationary contacts to just touch the "T" spring contacts, and tighten the mounting screws.

Note that the target should latch before the contacts make. Recheck Steps 1 and 3. The unit should pick up in one step, without excessive chatter, as current is gradually increased.

C. CONTACT CLEANING

For cleaning relay contacts, a flexible burnishing tool should be used. This consists of a flexible strip of metal with an etch-roughened surface resembling in effect a superfine file. The polishing action is so delicate that no scratches are left, yet it will clean off any corrosion thoroughly and rapidly. Its flexibility ensures the cleaning of the actual points of contact. Do not use knives, files, abrasive paper or cloth of any kind to clean relay contacts.

RENEWAL PARTS

It is recommended that sufficient quantities of renewal parts be carried in stock to enable the prompt replacement of any that are worn, broken, or damaged.

When ordering renewal parts, address the nearest Sales Office of the General Electric Company, specify the quantity required, the name of the part wanted, and the complete model number of the relay for which the part is required.

LIST OF FIGURES

<u>Figure</u>	<u>Page</u>
1 External Connections of Four Type-SFC Relays Used for Phase-To-Phase And Ground-Overcurrent Protection of a Three-phase Circuit.....	30
2 Functional Block Diagram of the SFC Relay.....	30
3 Rectifier and Tap Resistors.....	31
4 Pickup-Level Detector.....	31
5 Function Generator - Inverse Characteristic.....	32
6 Function Generator - Very-Inverse Characteristic.....	33
7 Function Generator - Extremely-Inverse Characteristic.....	34
8 Linear Ramp Generator.....	35
9 Level Detector.....	35
10 Output Circuit and Relay TOC.....	36
11 Power Supply.....	36
12 Printed-Circuit-Card Internal Connections for Type-SFC151A and B, and 152A and B Relay.....	37
13 Printed-Circuit-Card Internal Connections for Type-SFC153A and B, and 154A and B Relay.....	38
14 Printed-Circuit-Card Internal Connections for Type-SFC177A and B, and 178A and B Relay.....	39
15 Time-current Curves, SFC Time-overcurrent Relay Type-Inverse.....	40
16 Time-current Curves, SFC Time-overcurrent Relay Type-Very Inverse.....	41
17 Time-current Curves, SFC Time-overcurrent Relay Type - Extremely Inverse.....	42
18 High-Seismic Instantaneous Unit - Transient Overreach.....	43
19 High-Seismic Instantaneous Unit - Time-Current Curves.....	44
20 Overall Internal Connections (Front View) Type SFC151A 153A, 177A(-) Relay.....	45
21 Overall Internal Connections (Front View) Type SFC158B 153B, 177B(-) Relay.....	46
22 Overall Internal Connections (Front View) Type SFC152A 154A, 178A(-)A Relay.....	47
23 Overall Internal Connections (Front View) Type SFC152B 154B, 178B(-)A Relay.....	48
24 Test Connections, Type SFC Relay.....	49
25 SFC Relay - Front View (Removed from Case).....	50
26 SFC Relay - Rear View (Removed from Case).....	51
27 Outline and Panel-Drilling Dimensions for the SFC Relay....	52
28 Cutaway of Drawout Case, Showing Position of Auxiliary Brush and Shorting Bar.....	53

Since the last revision, Figure 27 has been changed.

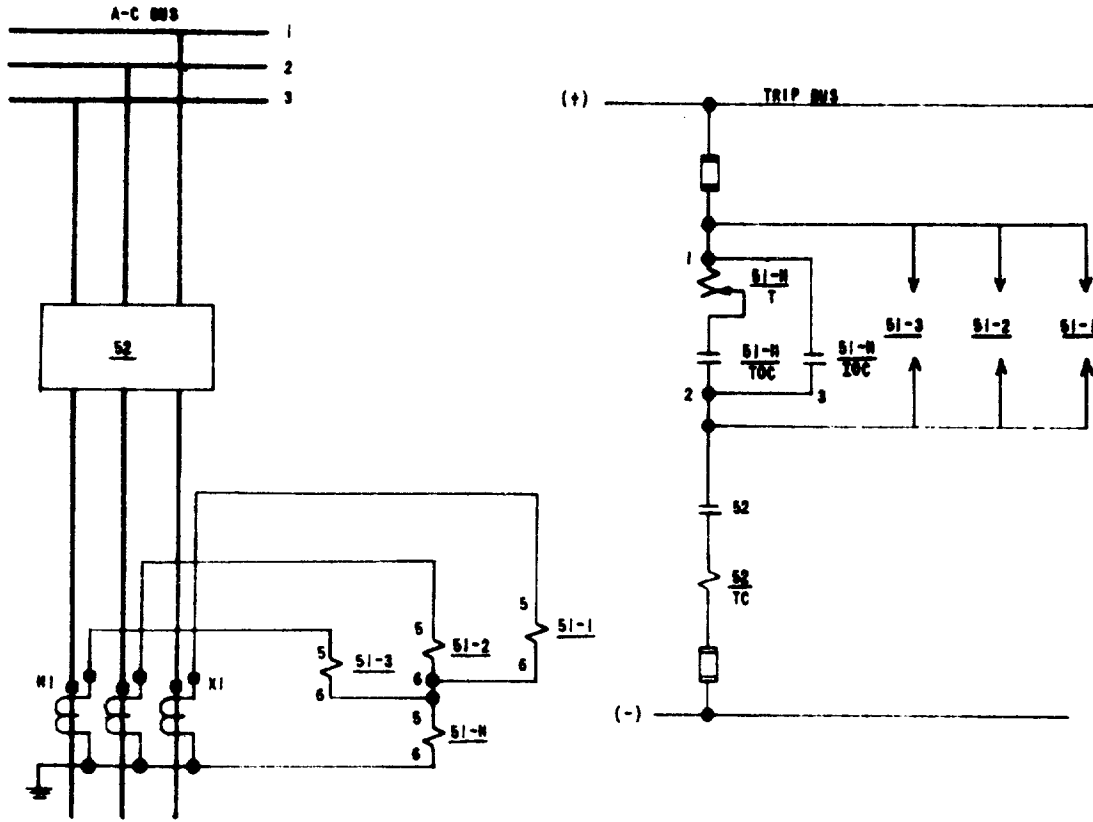

FIGURE 1

FIGURE 1. (0237A5008-0) EXTERNAL CONNECTIONS OF FOUR TYPE SFC RELAYS USED FOR PHASE-TO-PHASE AND GROUND OVERCURRENT PROTECTION OF A THREE-PHASE CIRCUIT

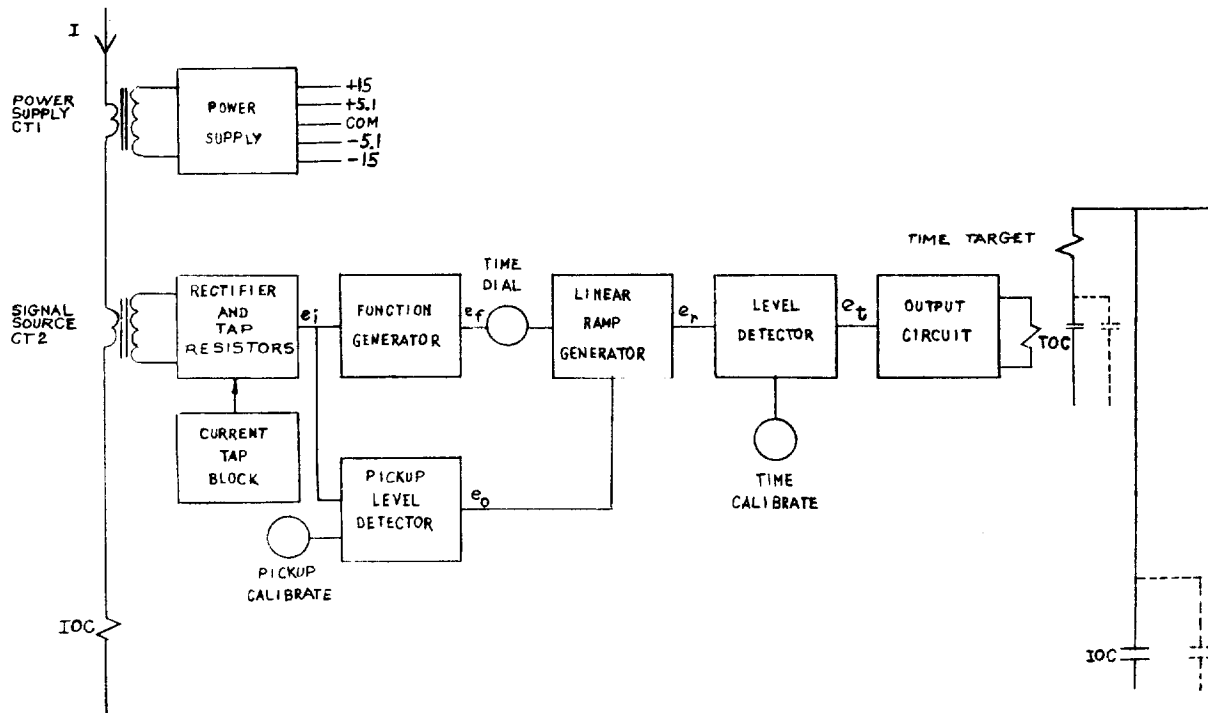

FIGURE 2. (0257A5009-1) FUNCTIONAL BLOCK DIAGRAM OF THE SFC RELAY

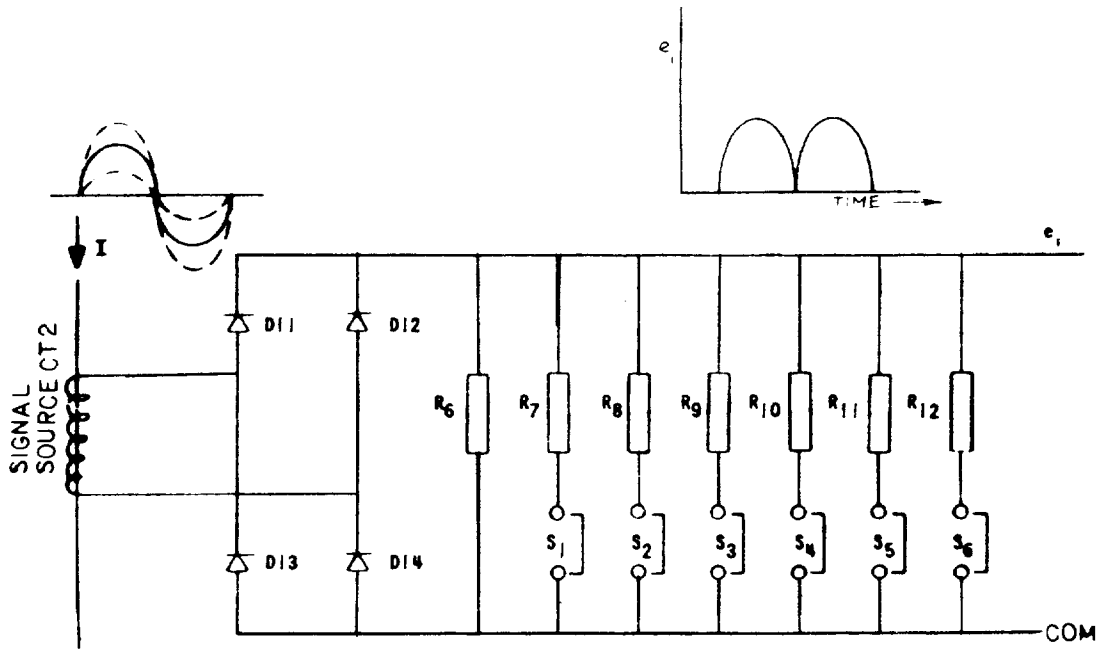

FIGURE 3. (0257A5010-2) RECTIFIER AND TAP RESISTORS

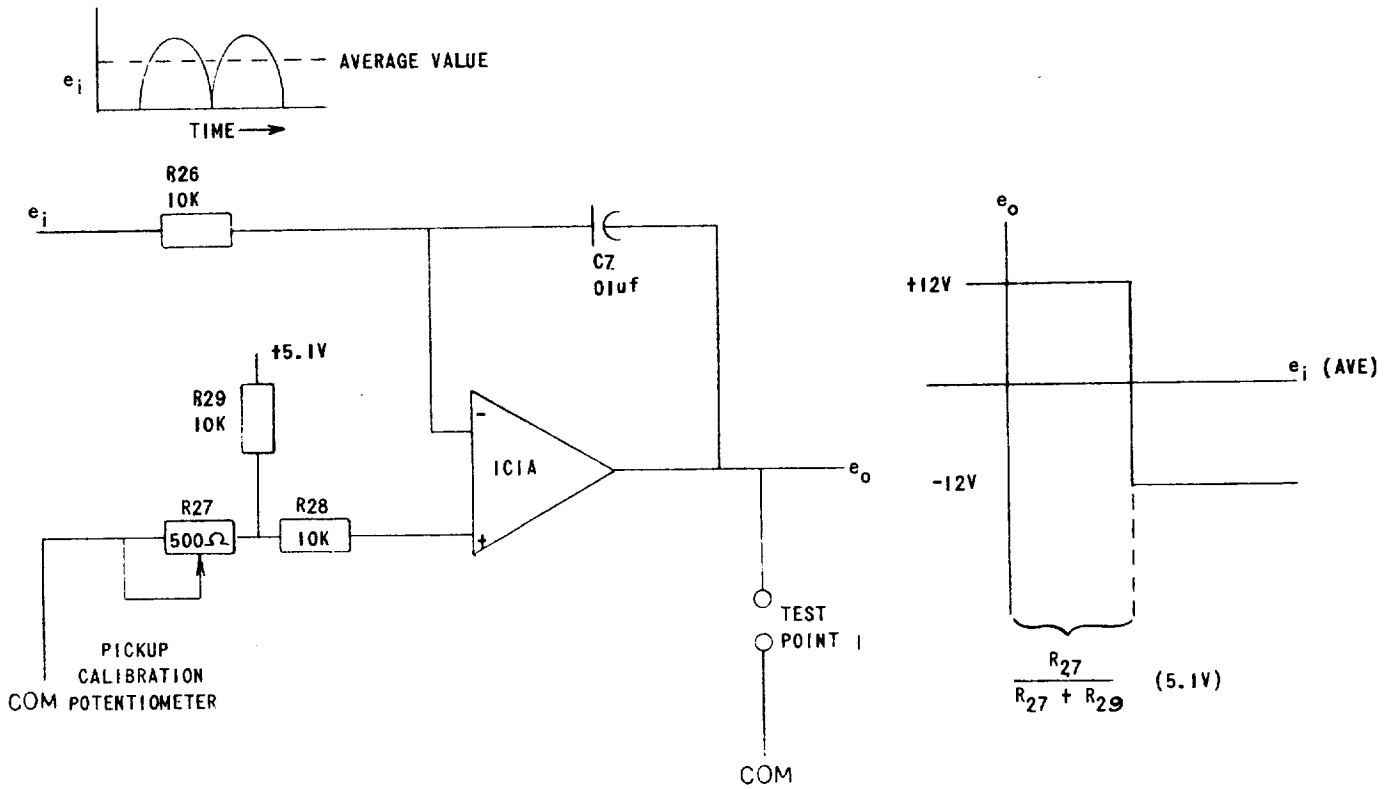

FIGURE 4. (0257A5011-2) PICKUP LEVEL DETECTOR

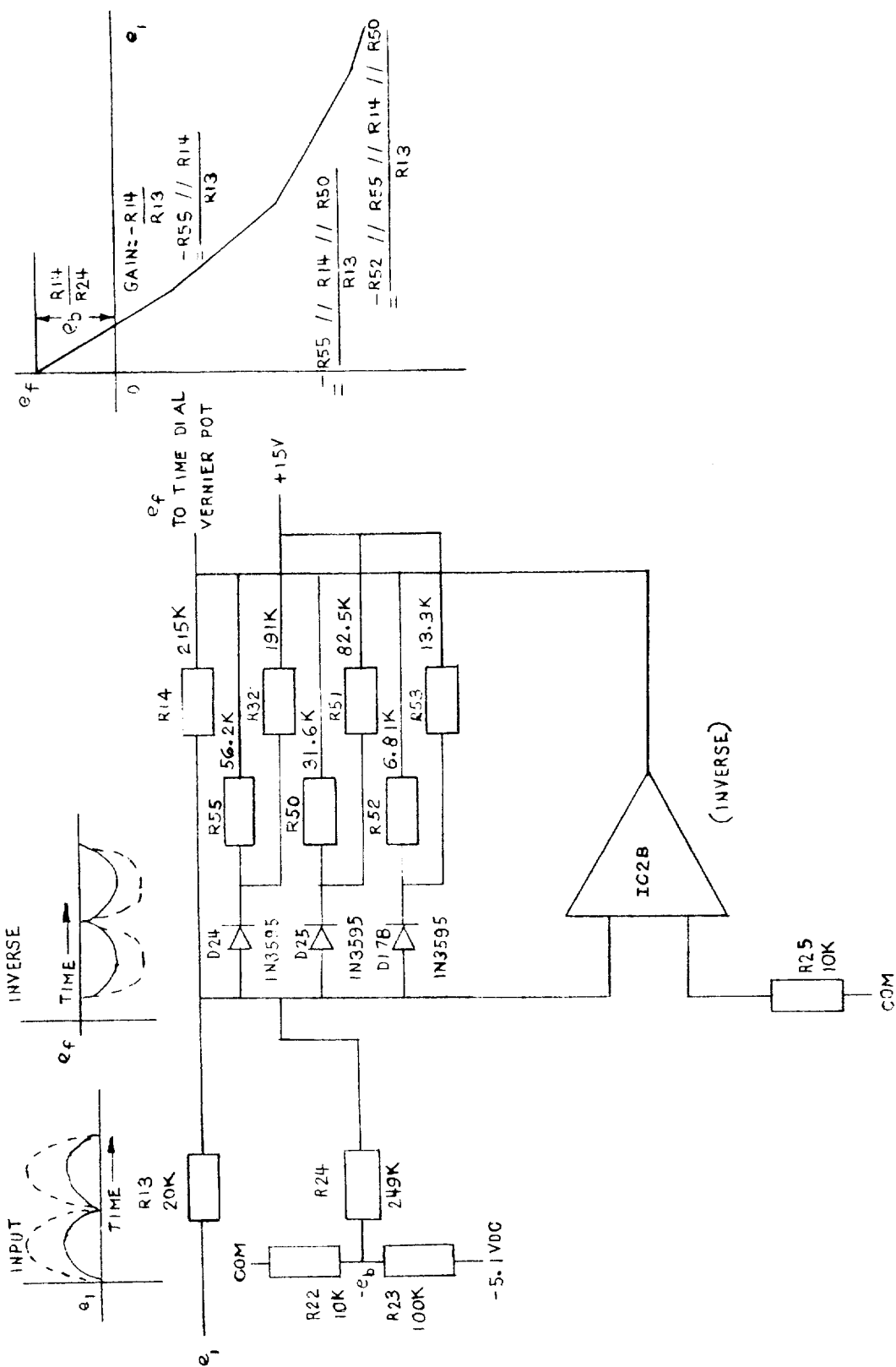

FIGURE 5. (0269A1760-2) FUNCTION GENERATOR - INVERSE CHARACTERISTIC

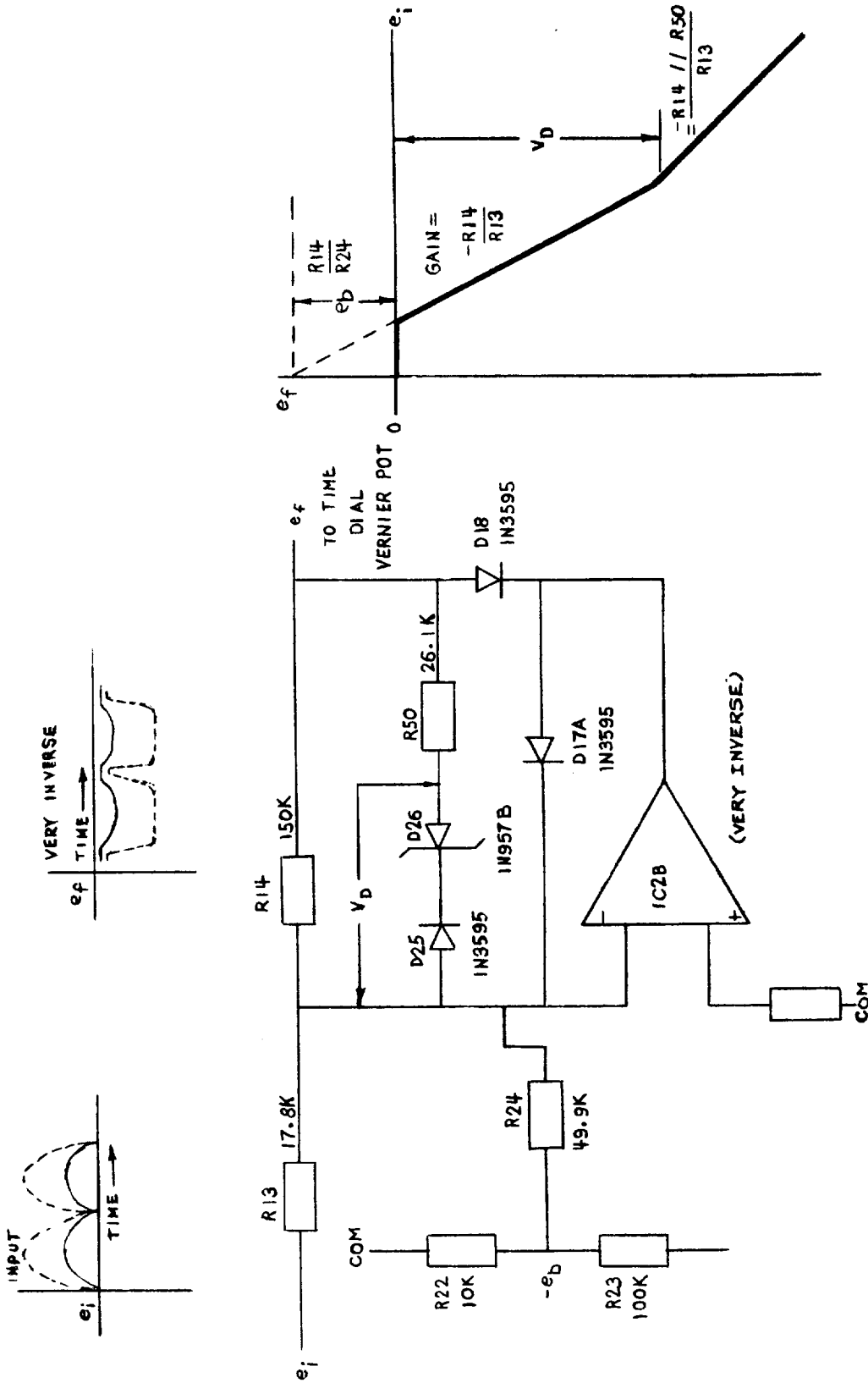

FIGURE 6. (0269A1761-0) FUNCTION GENERATOR - VERY INVERSE CHARACTERISTIC

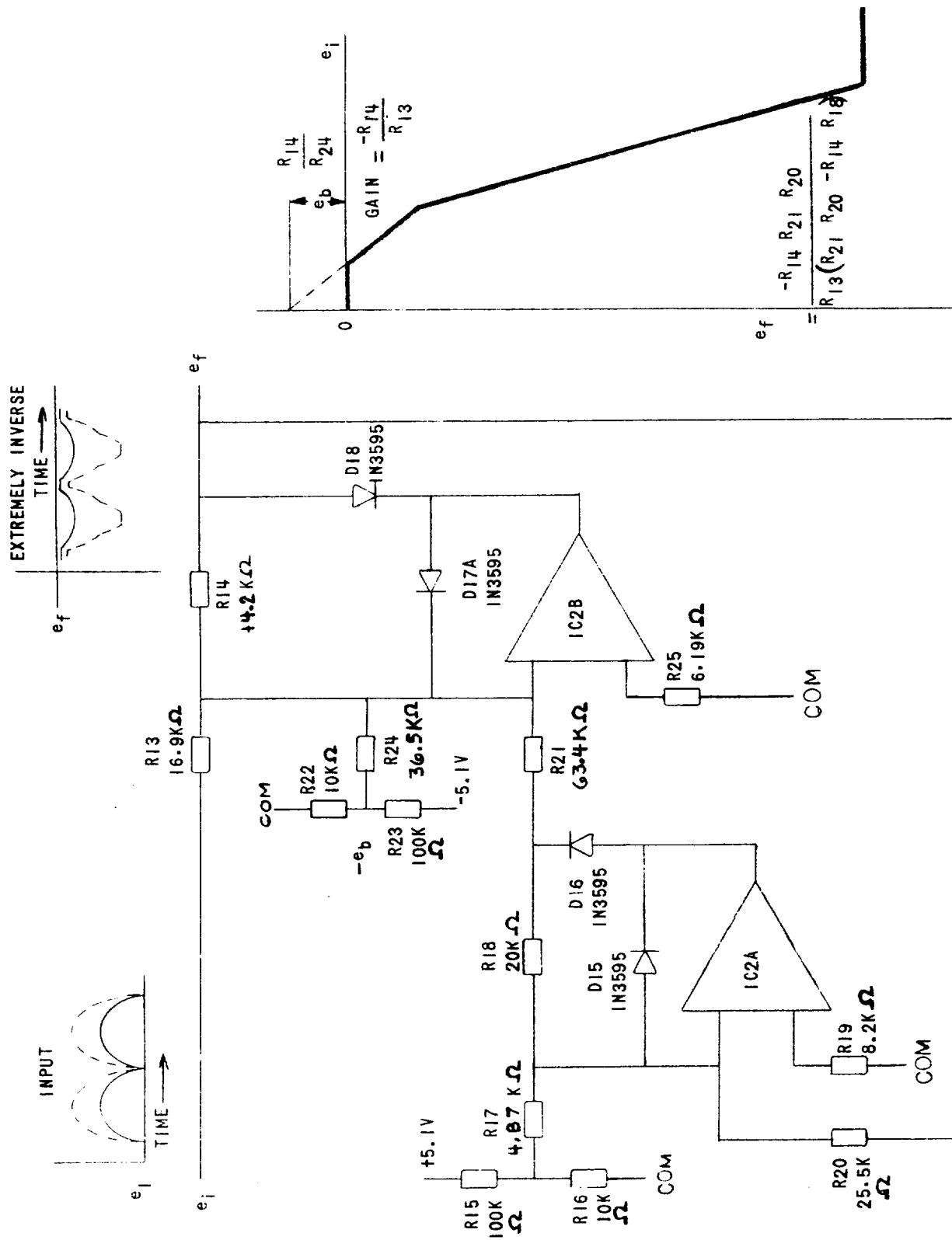

FIGURE 7. (0257A5013-3) FUNCTION GENERATOR - EXTREMELY INVERSE CHARACTERISTIC

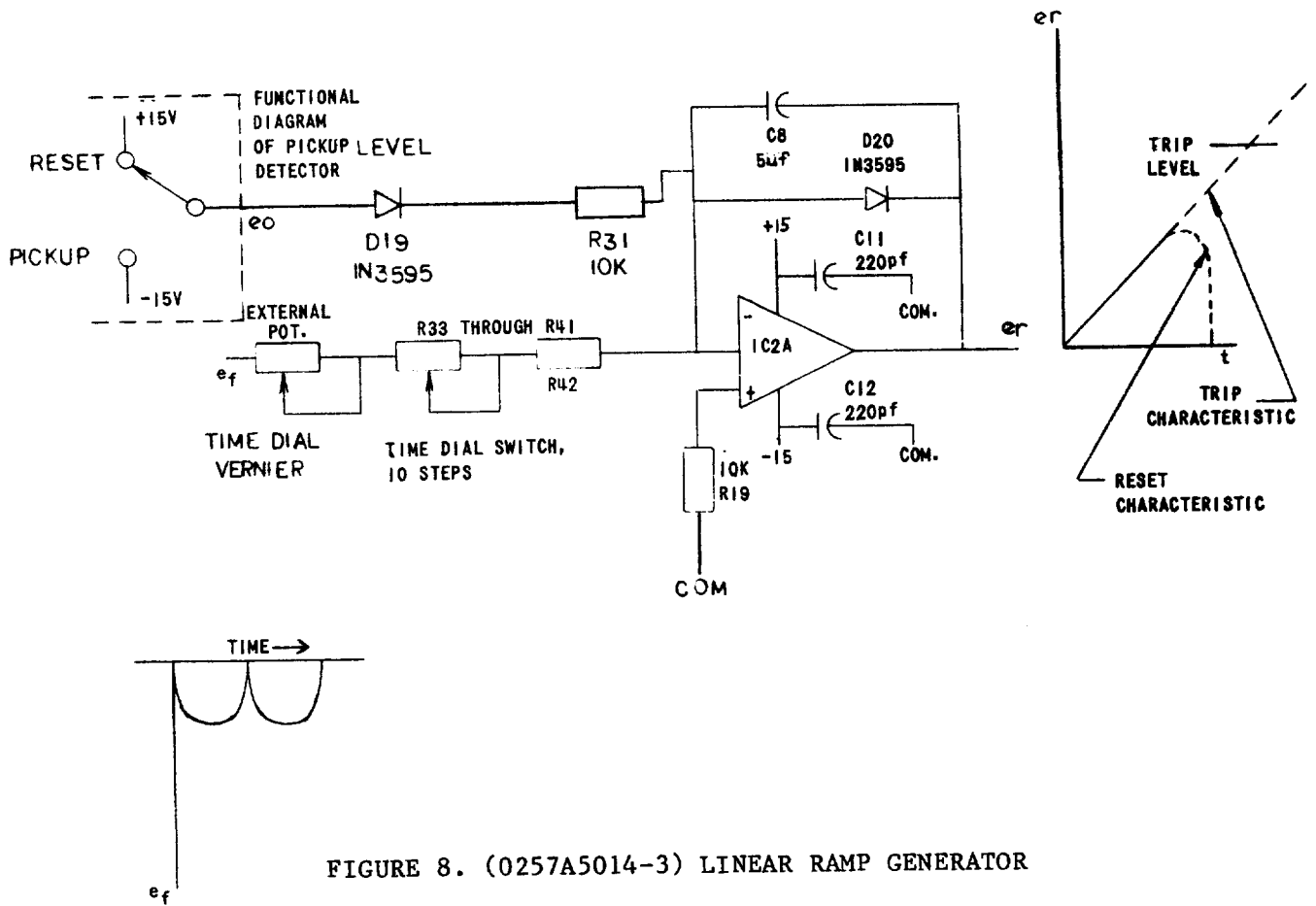

FIGURE 8. (0257A5014-3) LINEAR RAMP GENERATOR

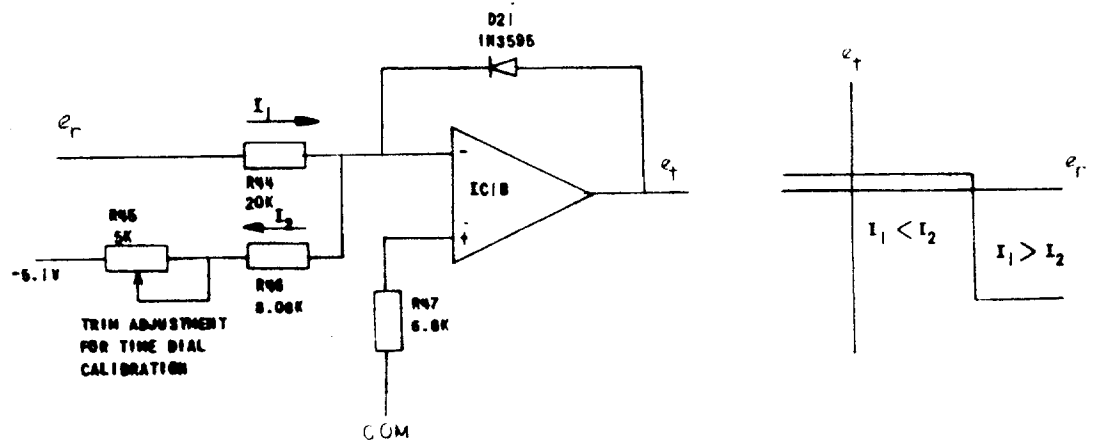

FIGURE 9. (0257A5015-1) LEVEL DETECTOR

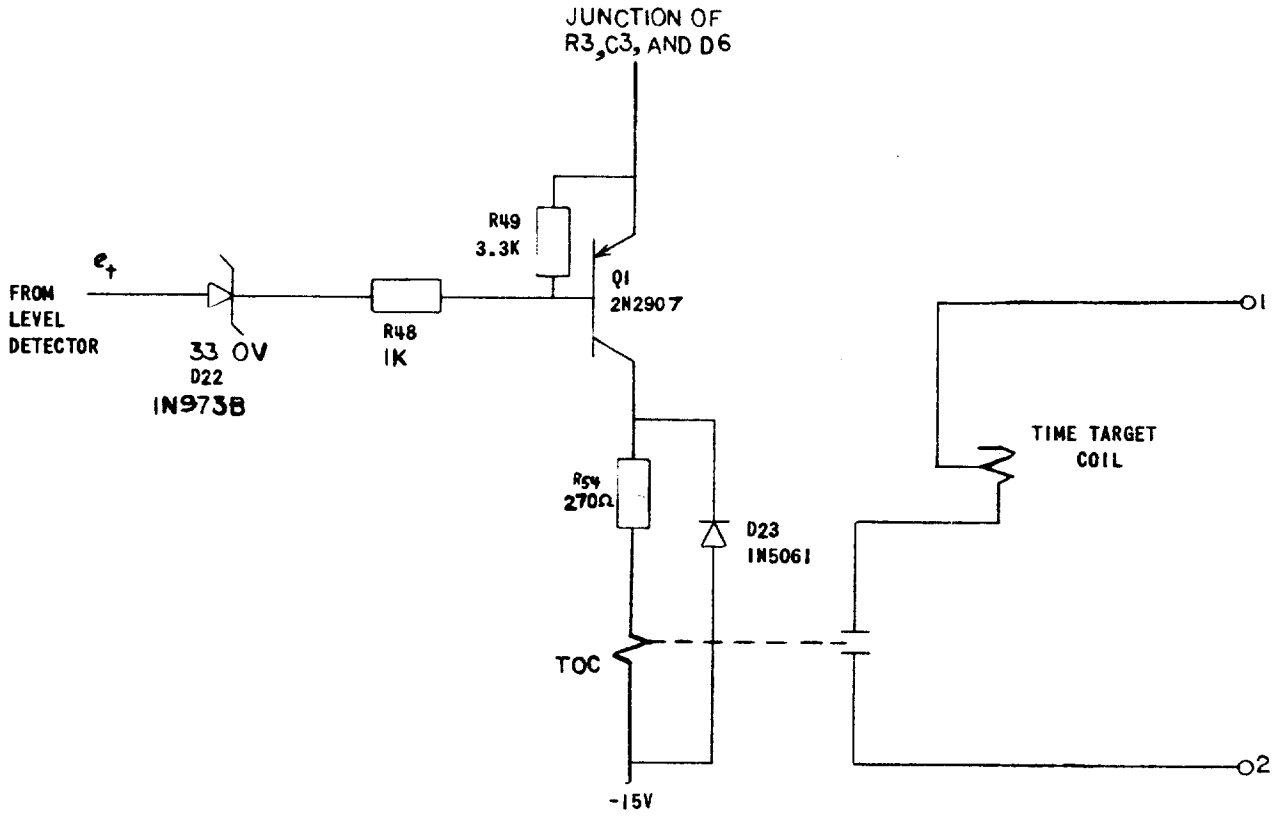

FIGURE 10. (0257A5016-3) OUTPUT CIRCUIT AND RELAY TOC

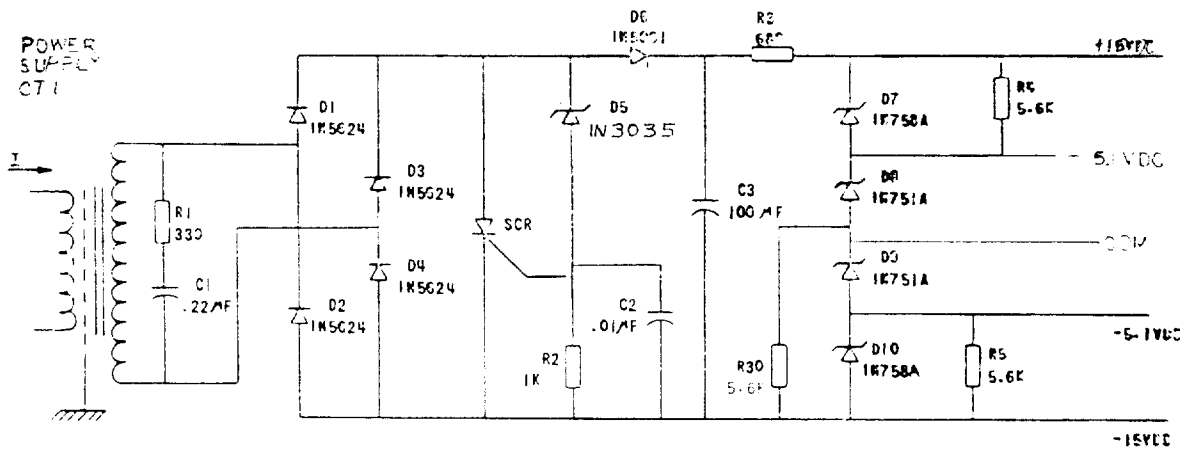

FIGURE 11. (0257A5017-3) POWER SUPPLY

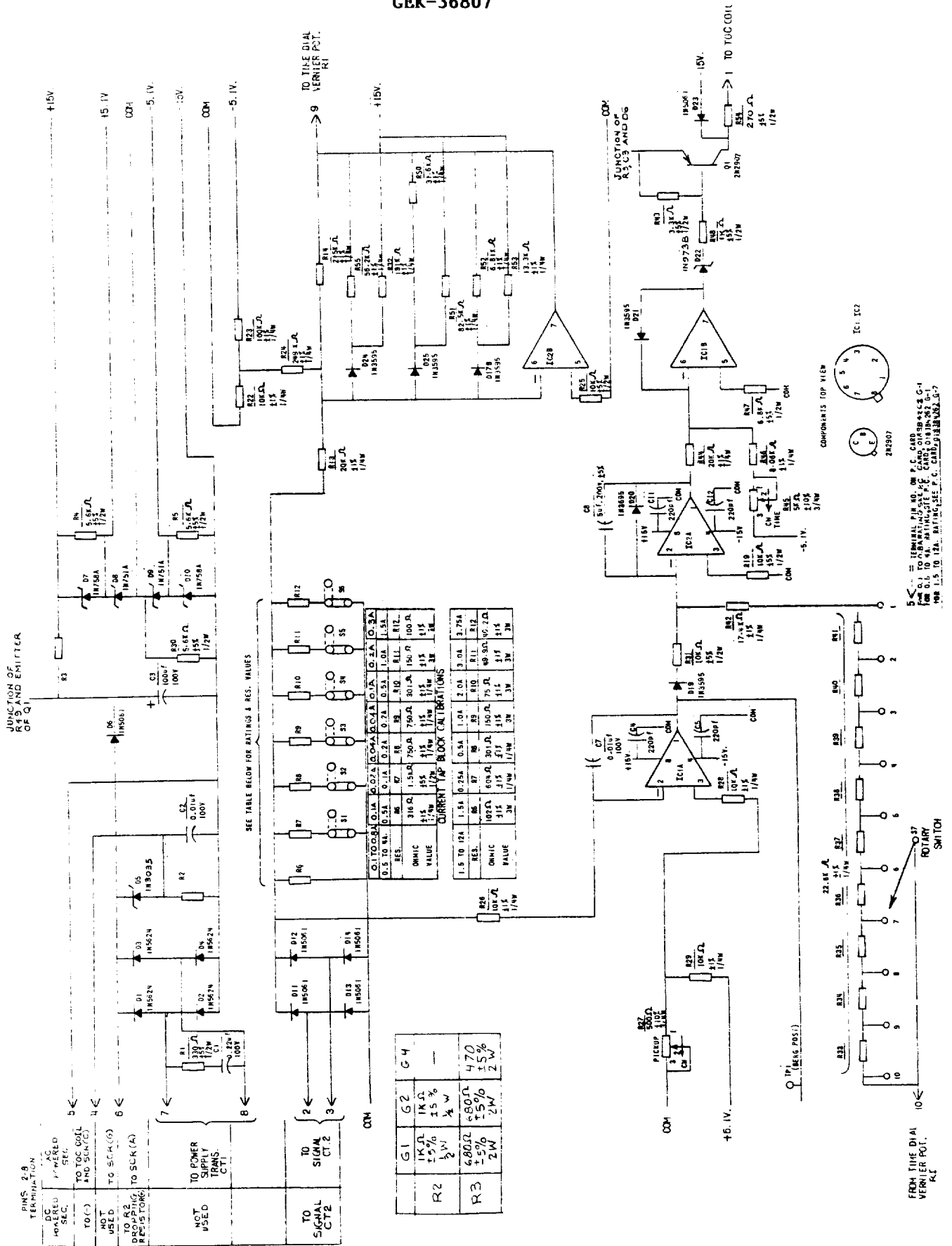

FIGURE 12. (0152C4378-11) PRINTED-CIRCUIT-CARD INTERNAL CONNECTIONS FOR TYPE SFC151A AND B, 152A AND B RELAY

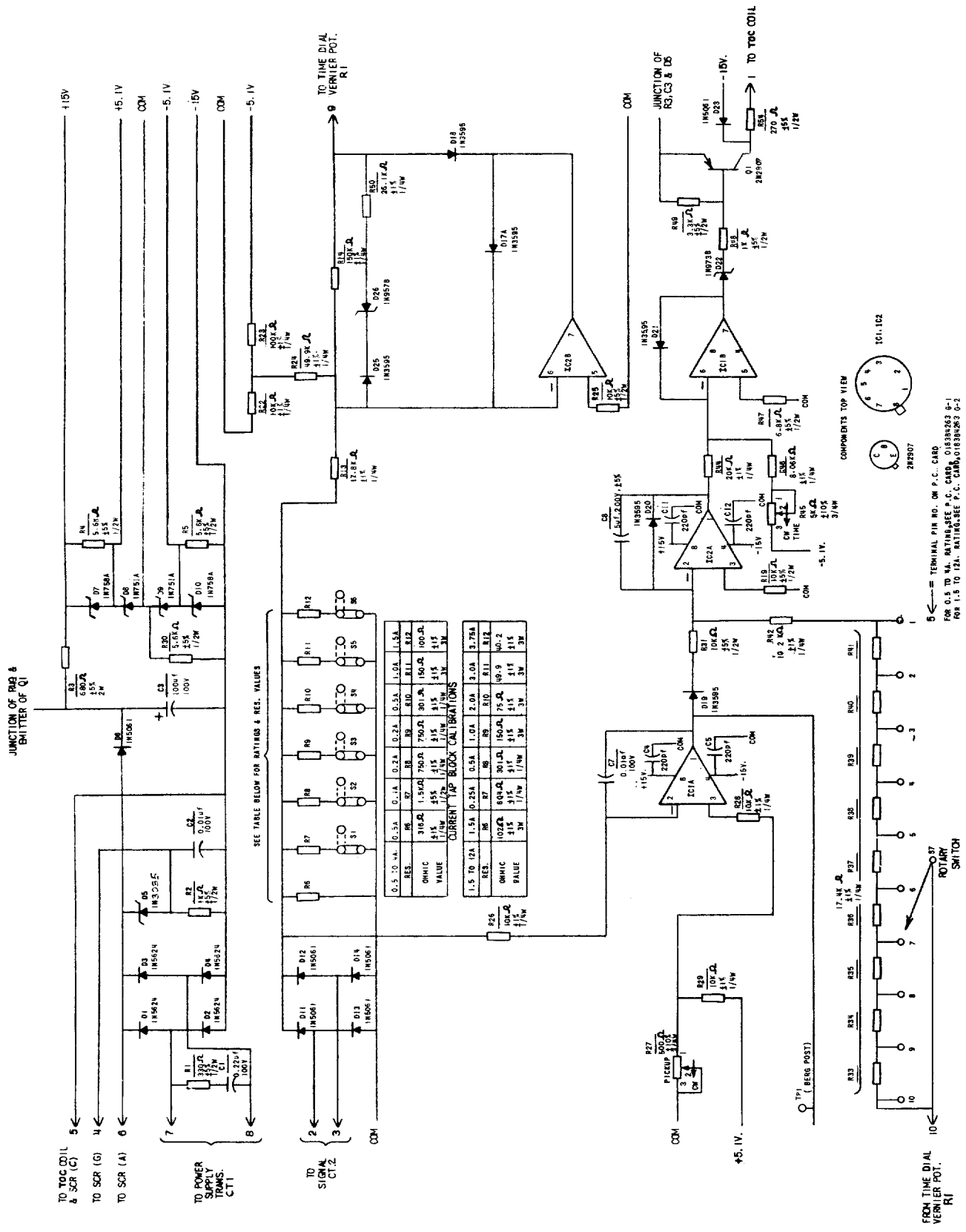

FIGURE 13. (0152C4379-9) PRINTED-CIRCUIT-CARD INTERNAL CONNECTION FOR TYPE SFC153A AND B, 154A AND B RELAY

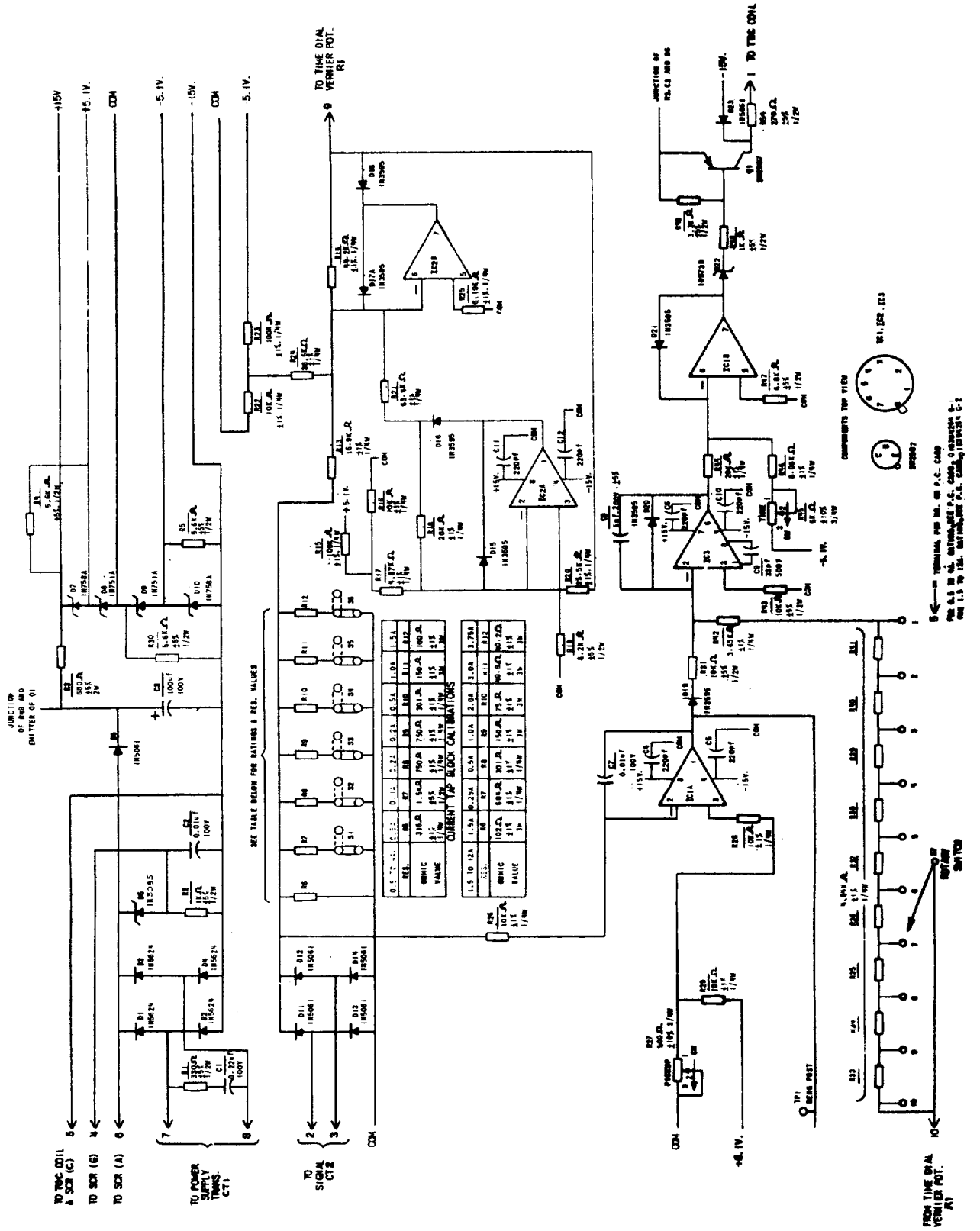

FIGURE 14. (0152C4380-6) PRINTED-CIRCUIT-CARD INTERNAL CONNECTIONS FOR TYPE SFC177A AND B, SFC178A AND B RELAY

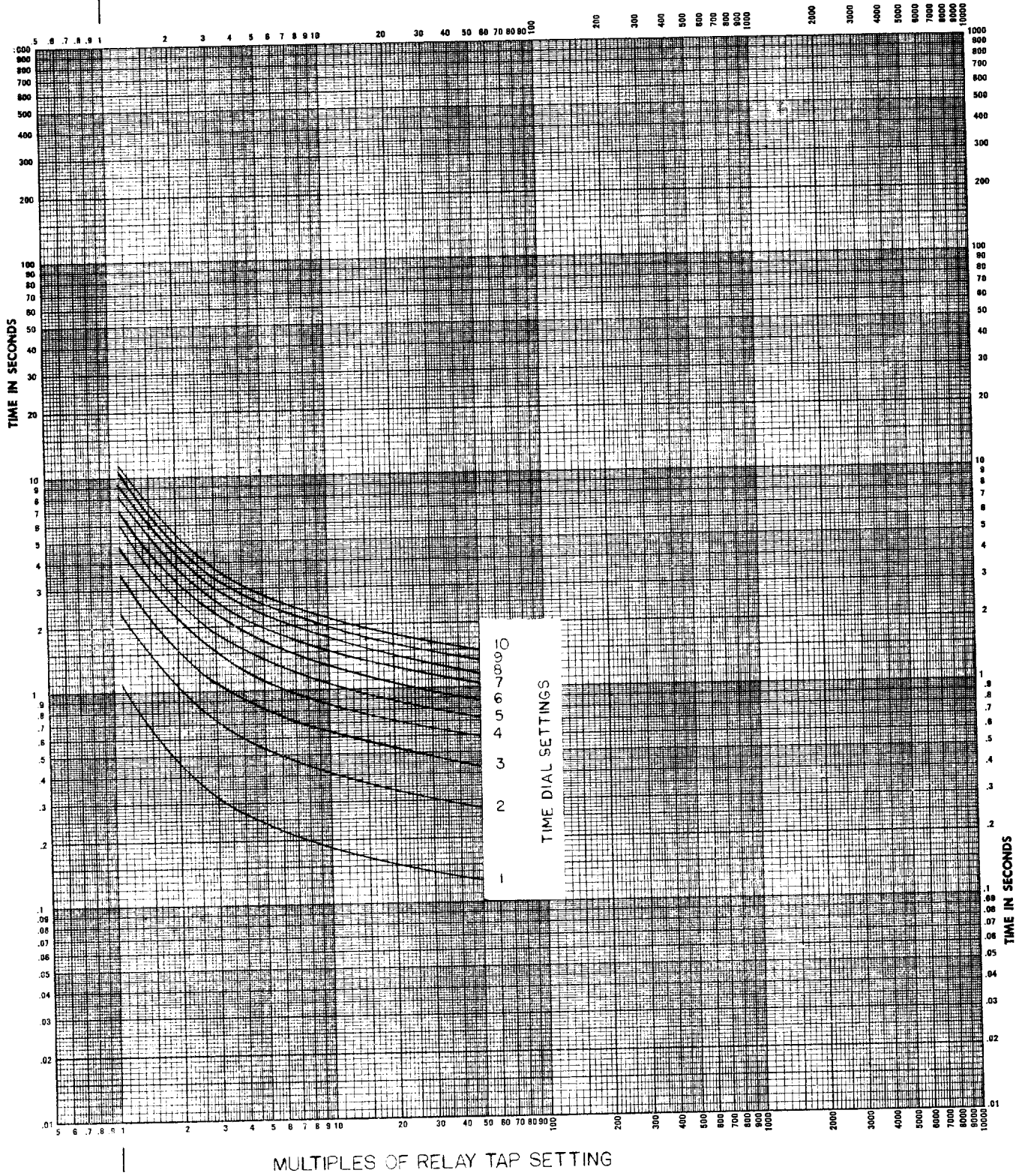

FIGURE 15. (0183B7887-4) TIME-CURRENT CURVES SFC TIME-OVERCURRENT RELAY TYPE-INVERSE

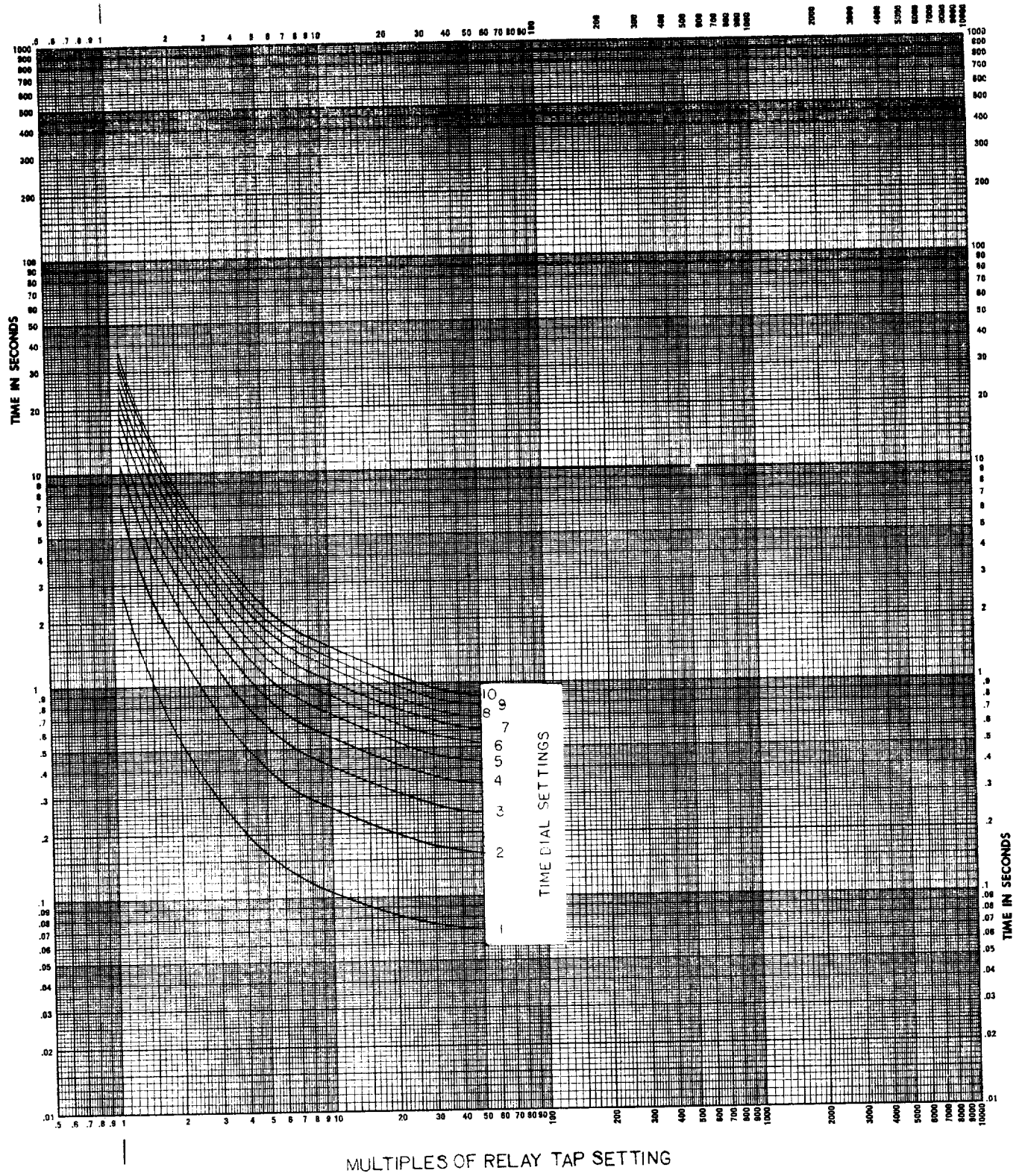

FIGURE 16. (0183B7888-3) TIME-CURRENT CURVES
SFC TIME-OVERCURRENT RELAY TYPE - VERY INVERSE

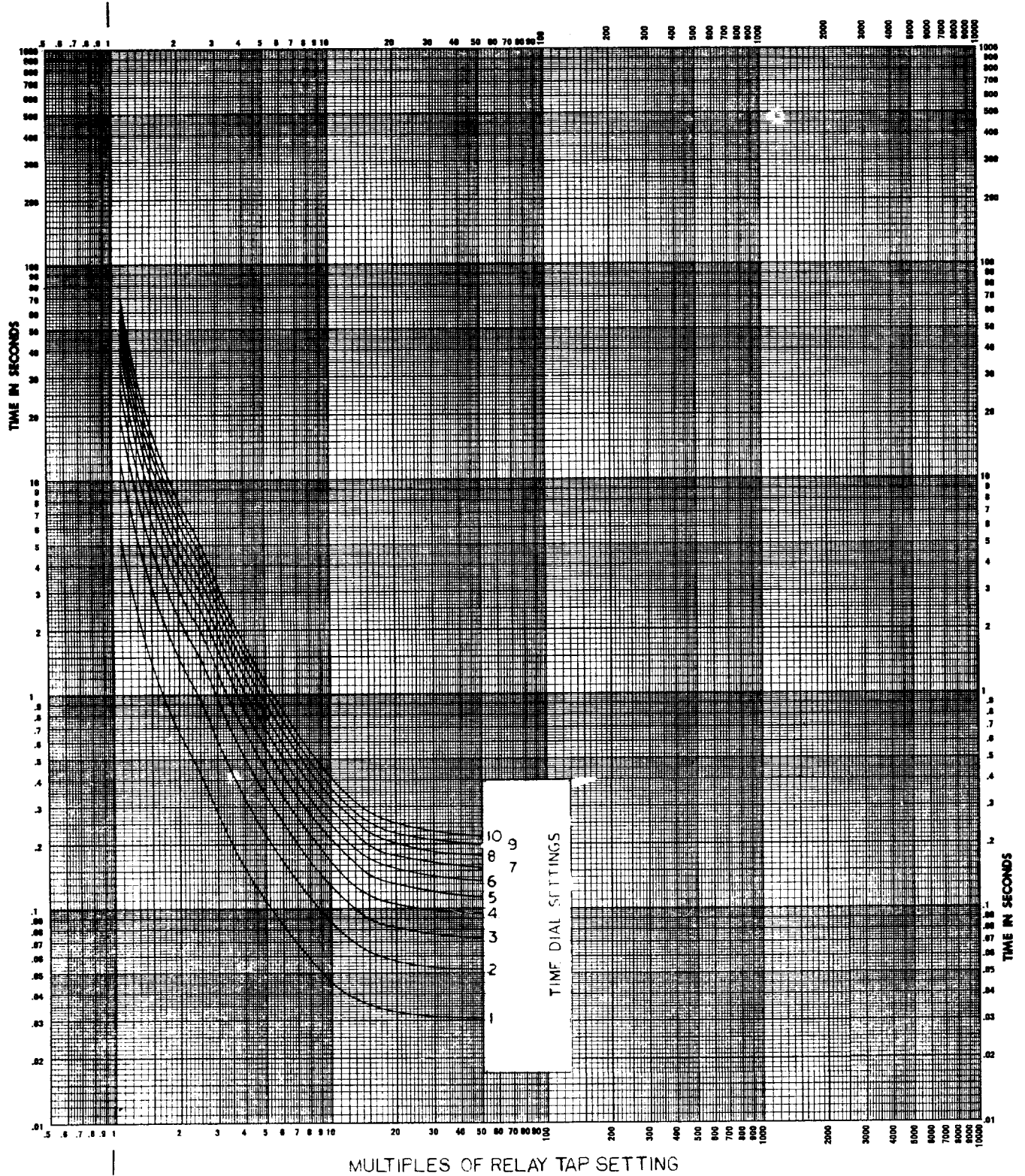

FIGURE 17. (0183B7889-4) TIME-CURRENT CURVES
SFC TIME-OVERCURRENT RELAY TYPE -EXTREMELY INVERSE

HI SEISMIC RATED INSTANTANEOUS UNIT
TRANSIENT OVERREACH

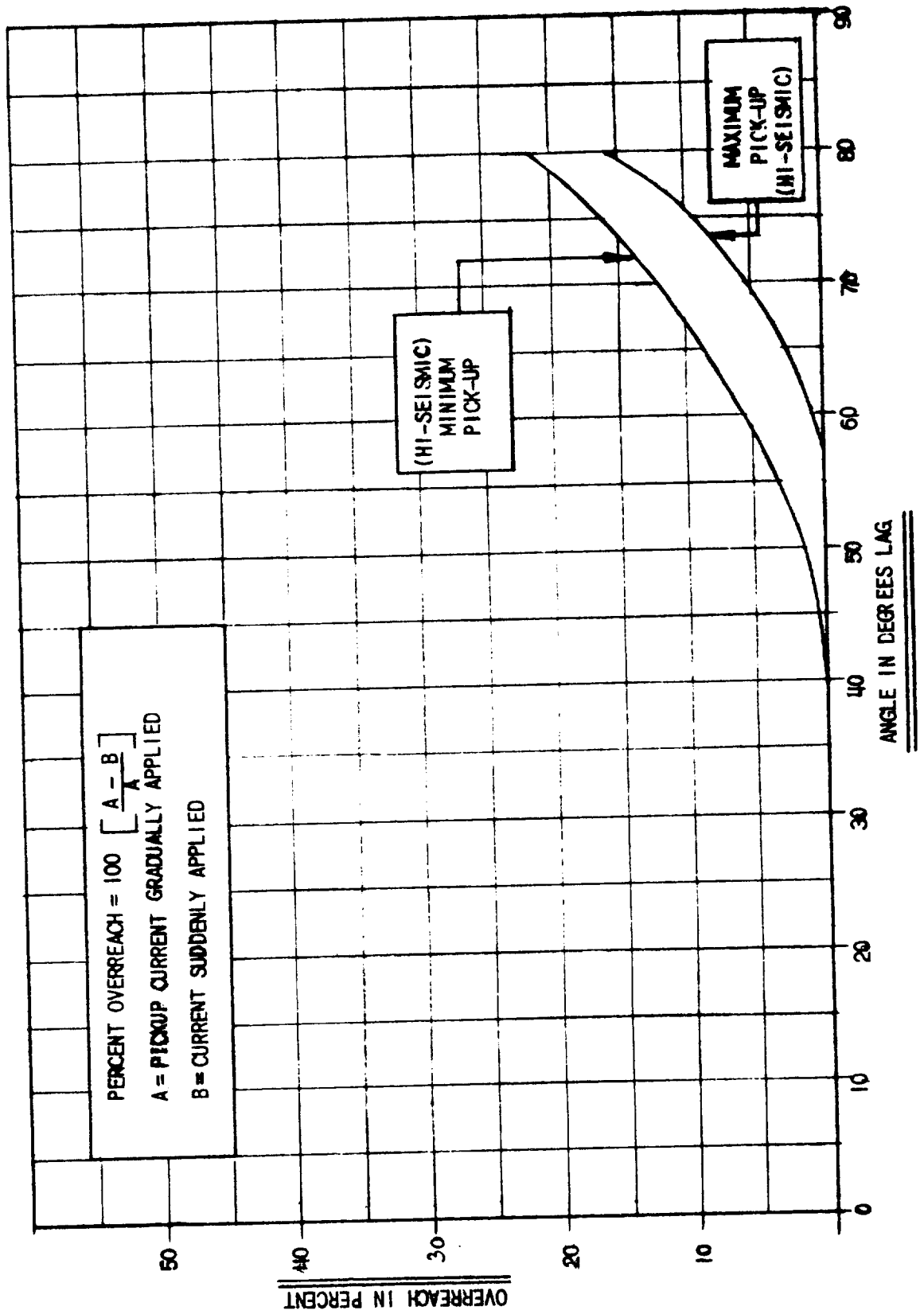

FIGURE 18. (0208A8694-2) HIGH-SEISMIC INSTANTANEOUS UNIT - TRANSIENT OVERREACH

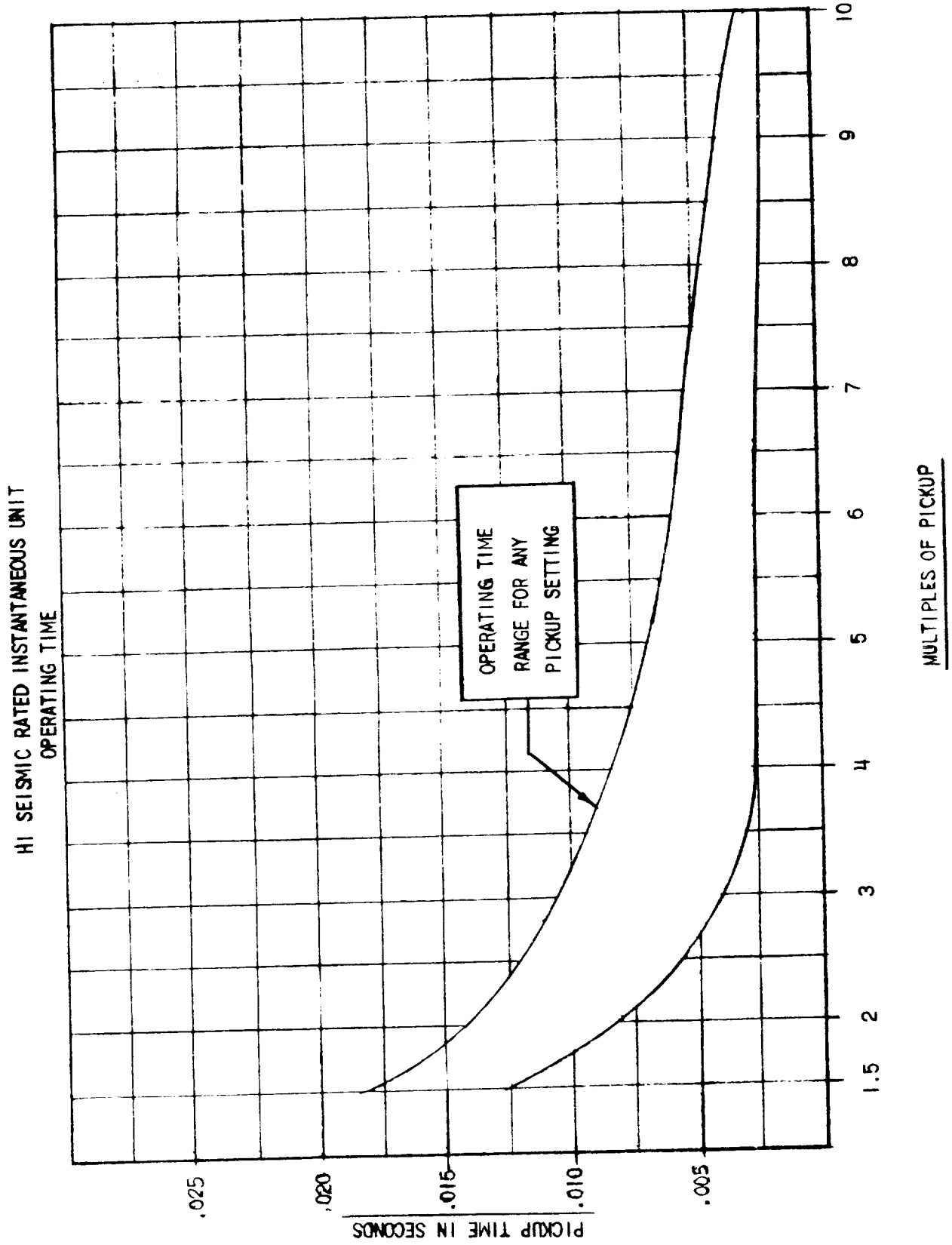
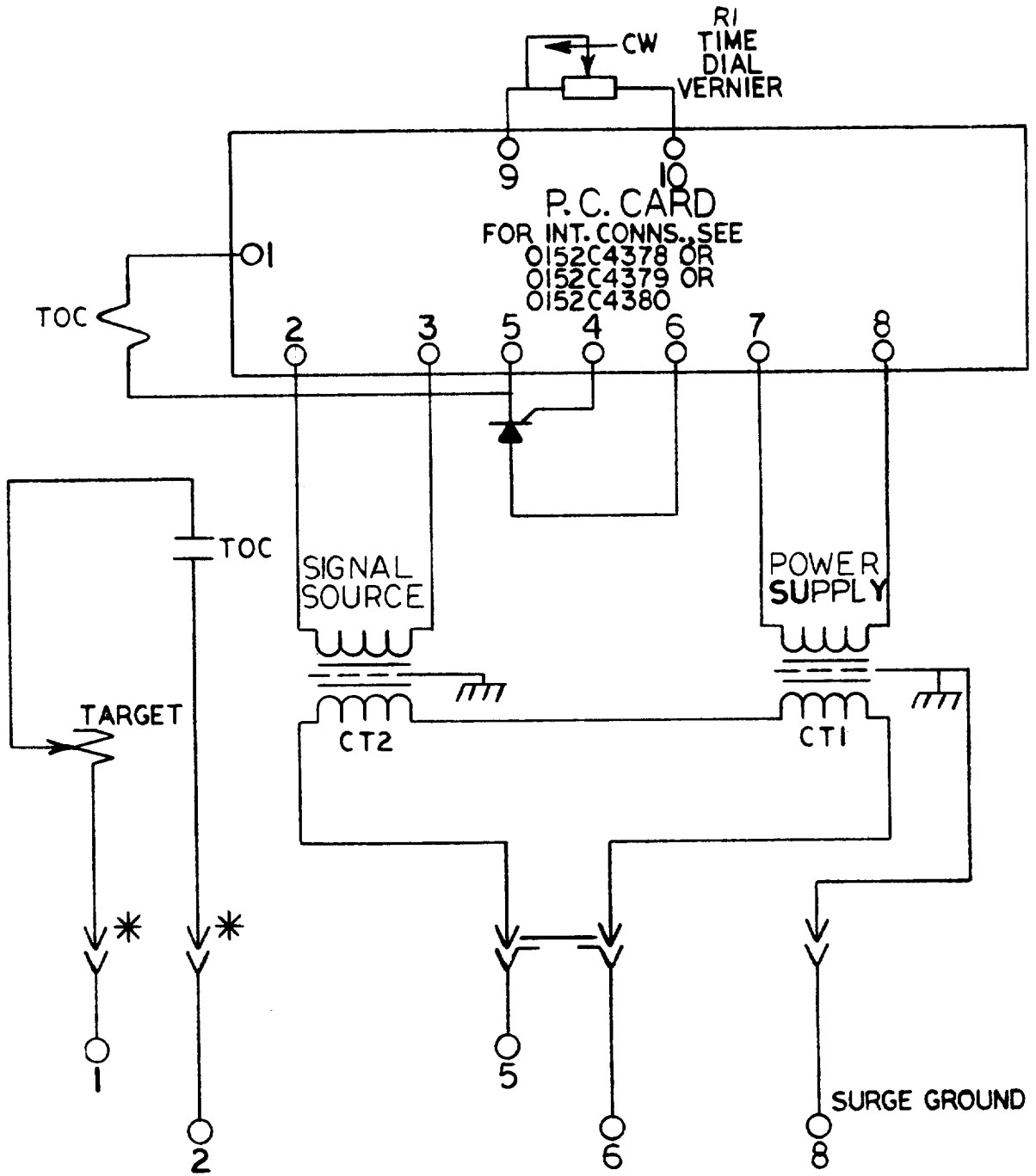

FIGURE 19. (0208A8695-1) HIGH-SEISMIC INSTANTANEOUS UNIT - TIME-CURRENT CURVES



* = SHORT FINGERS

FIGURE 20. (0246A6809-3) OVERALL INTERNAL CONNECTIONS (FRONT VIEW)
TYPE SFC151A, 153A, 177A(-) A RELAY

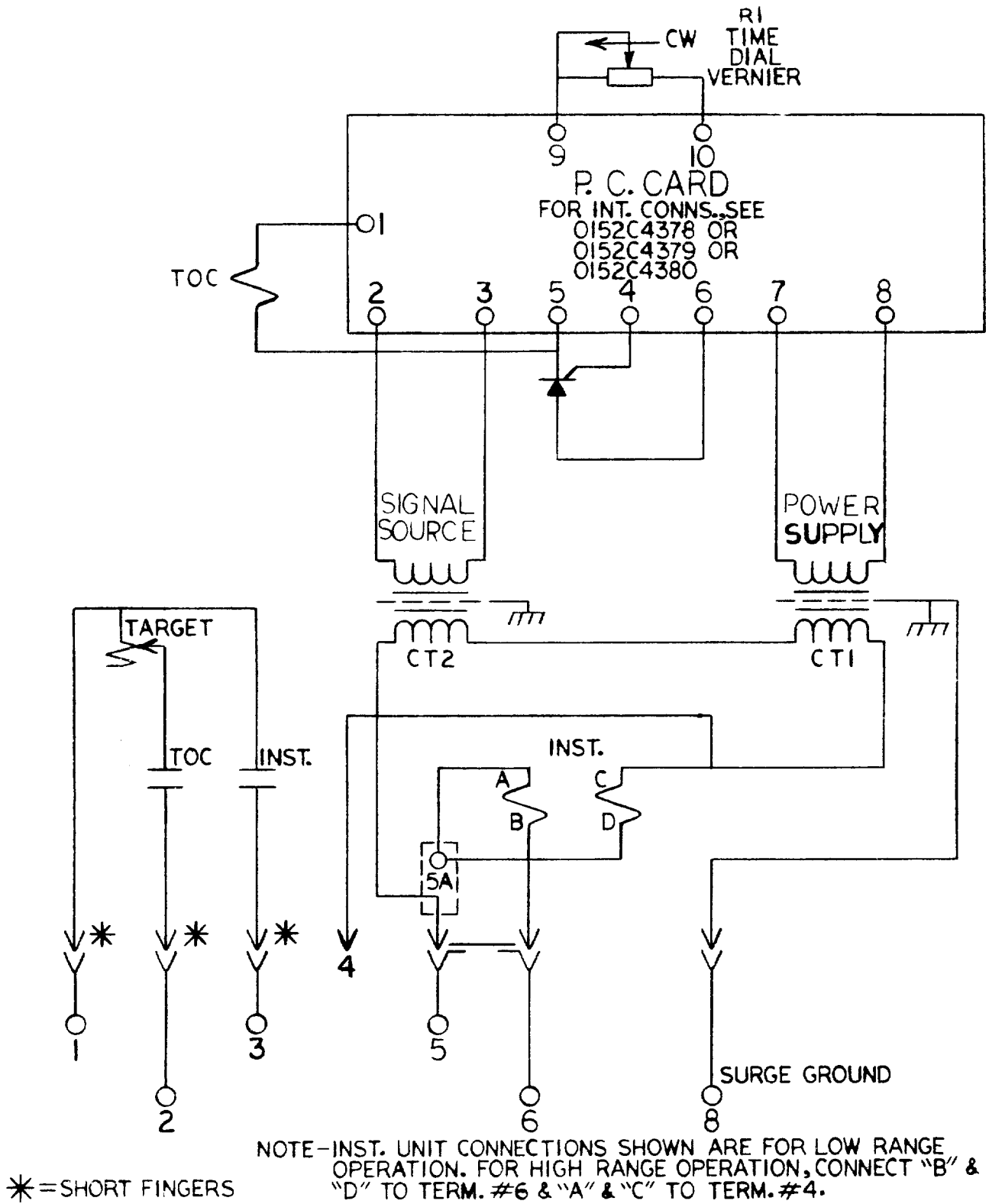
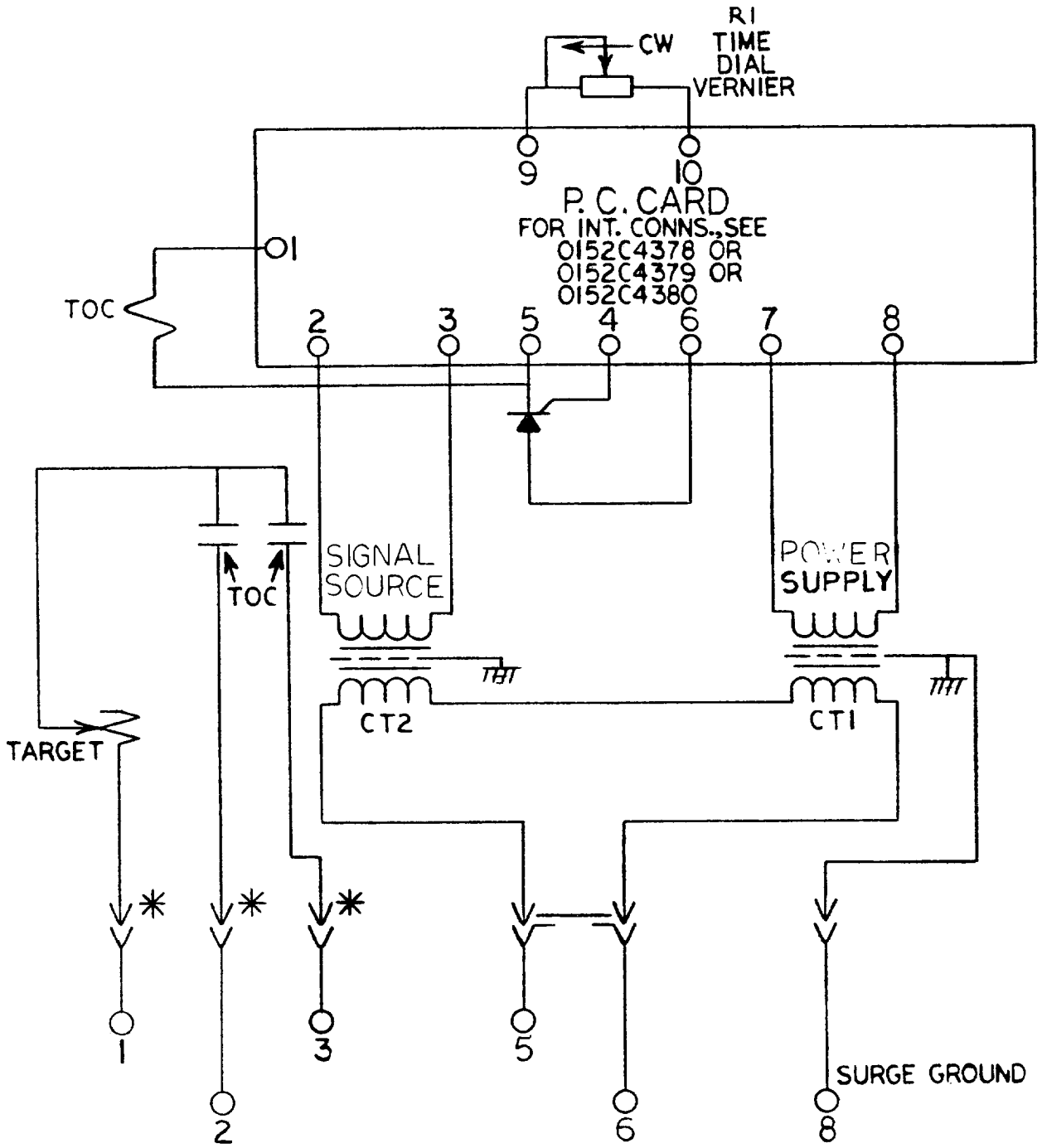
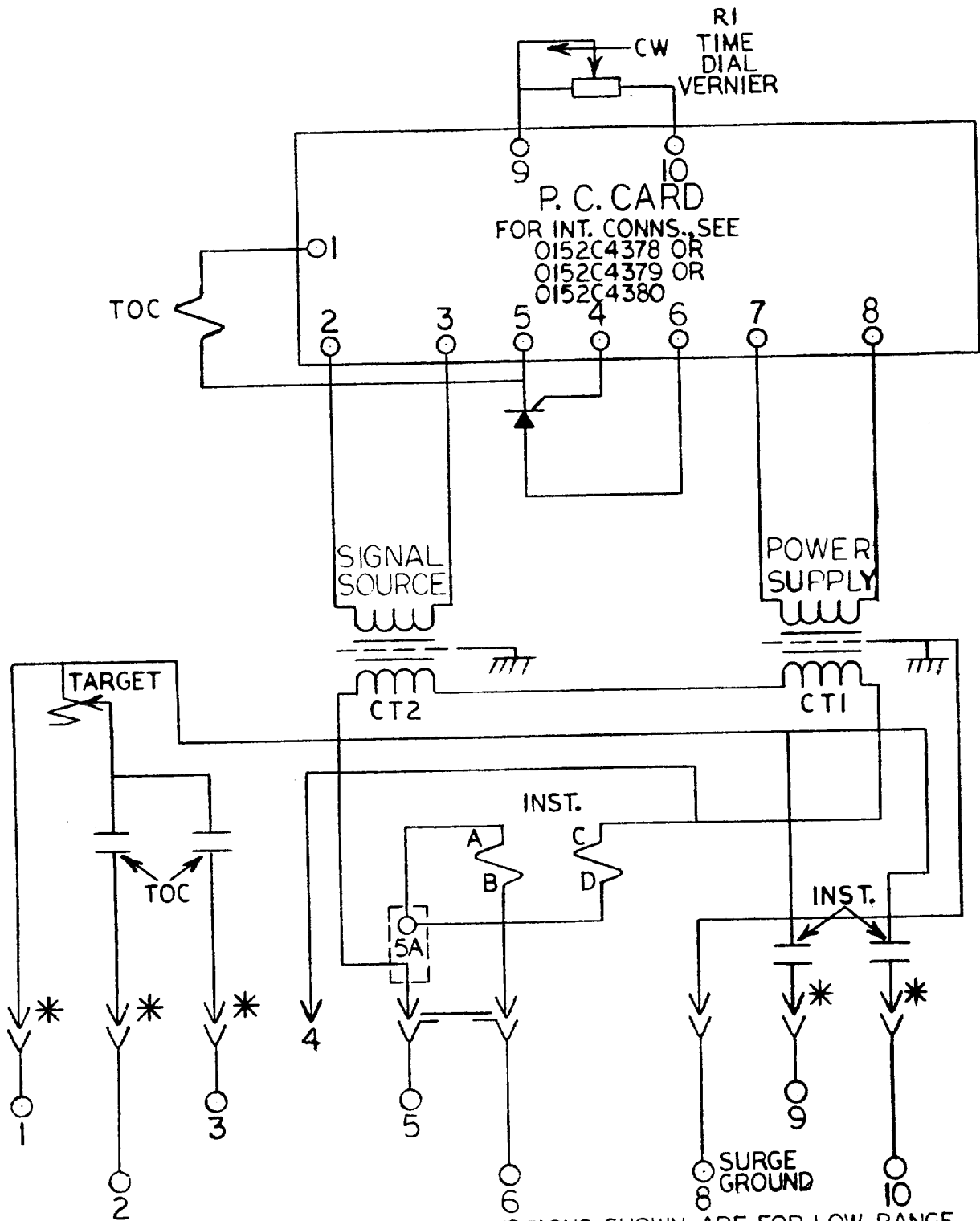

FIGURE 21. (0246A6810-3) OVERALL INTERNAL CONNECTIONS (FRONT VIEW)
TYPE SFC151B, 153B, 177B(-)A RELAY



* = SHORT FINGERS

FIGURE 22. (0246A6837-3) OVERALL INTERNAL CONNECTIONS (FRONT VIEW)
TYPE SFC152, 154A, 178A(-) RELAY



NOTE—INST. UNIT CONNECTIONS SHOWN ARE FOR LOW RANGE OPERATION. FOR HIGH RANGE OPERATION, CONNECT "B" & "D" TO TERM. #6 & "A" & "C" TO TERM. #4.

*=SHORT FINGERS

FIGURE 23. (0246A6838-3) OVERALL INTERNAL CONNECTIONS (FRONT VIEW)
TYPE SFC152B, 154B, 178B(-) A RELAY

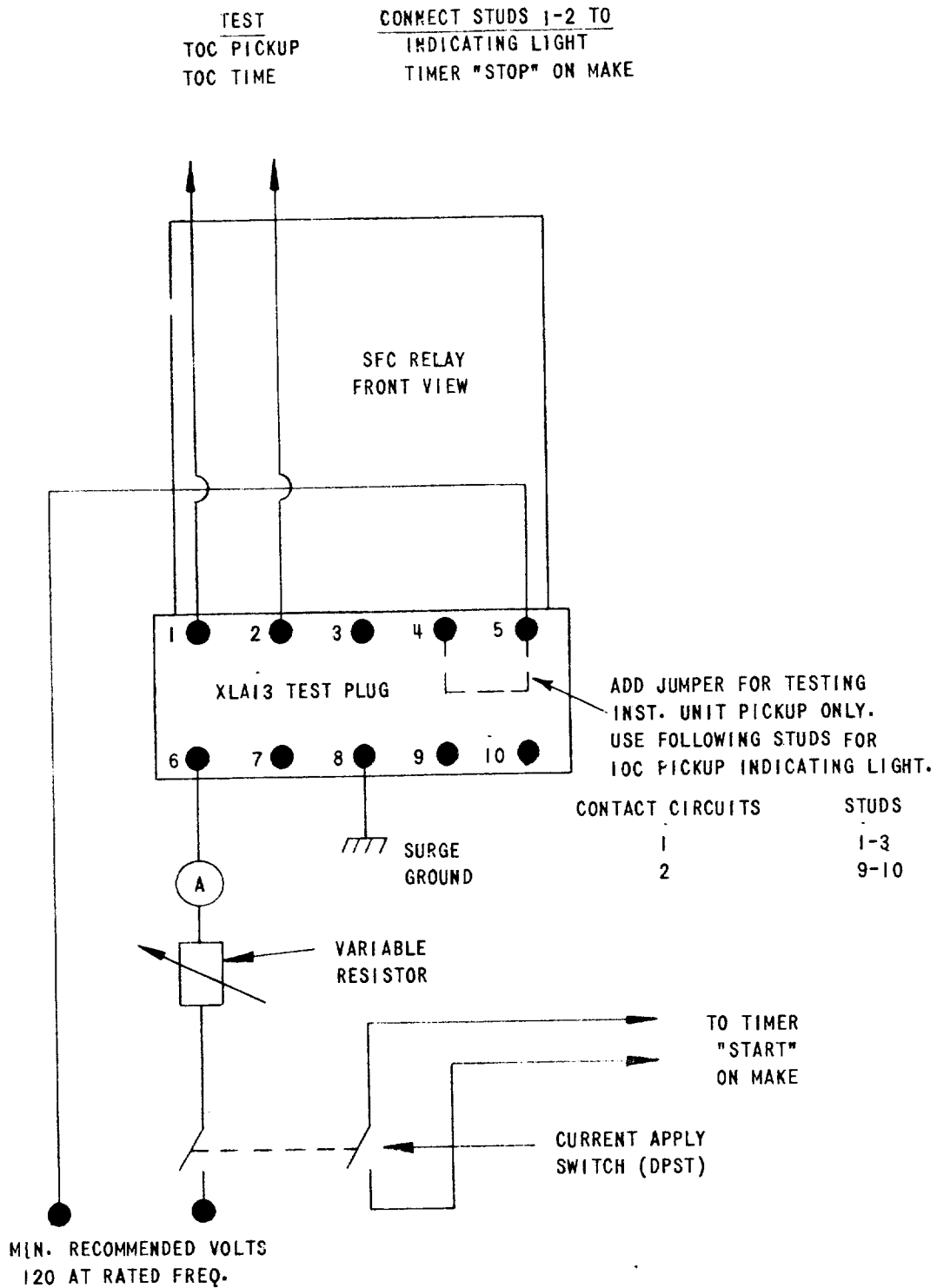
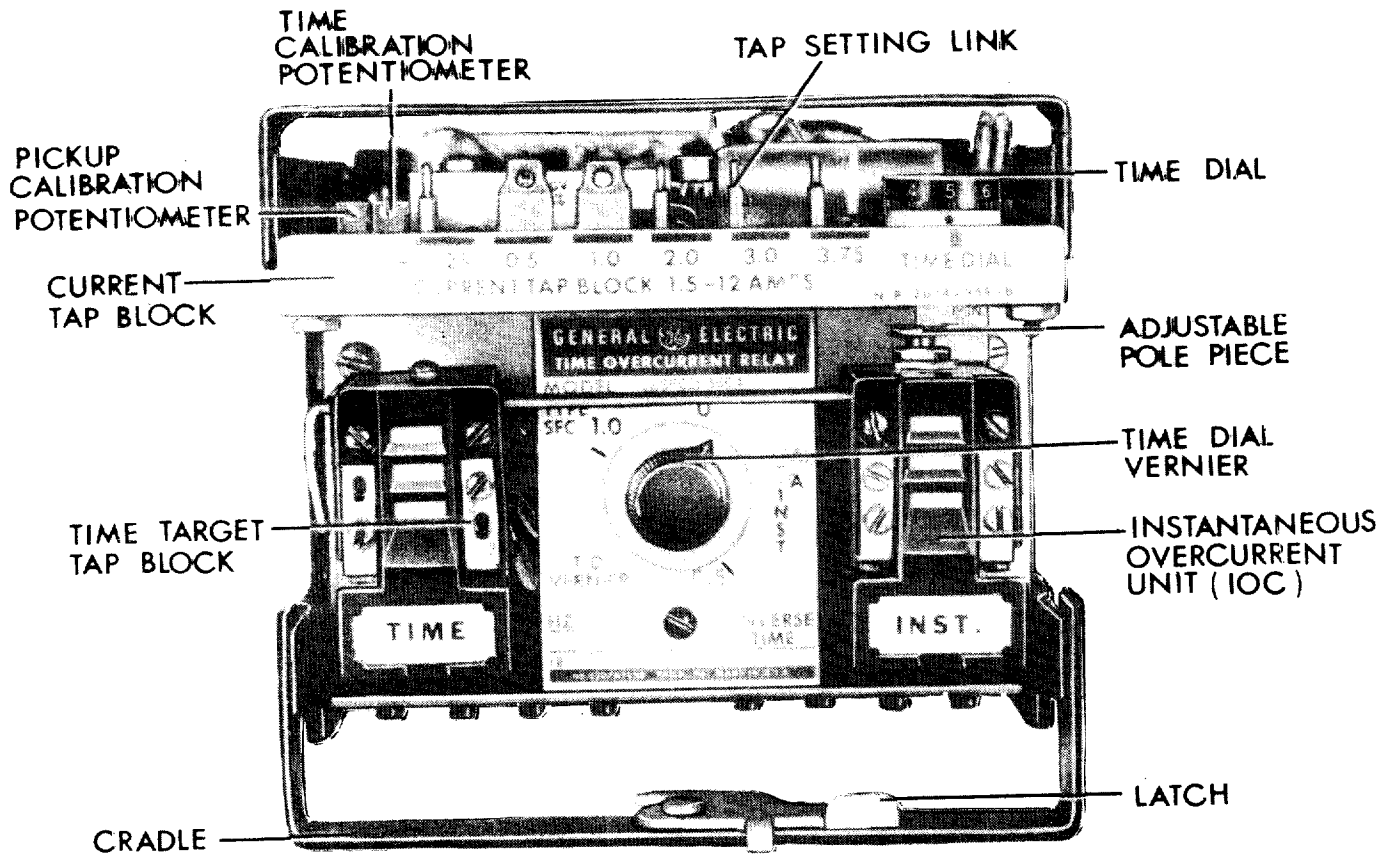
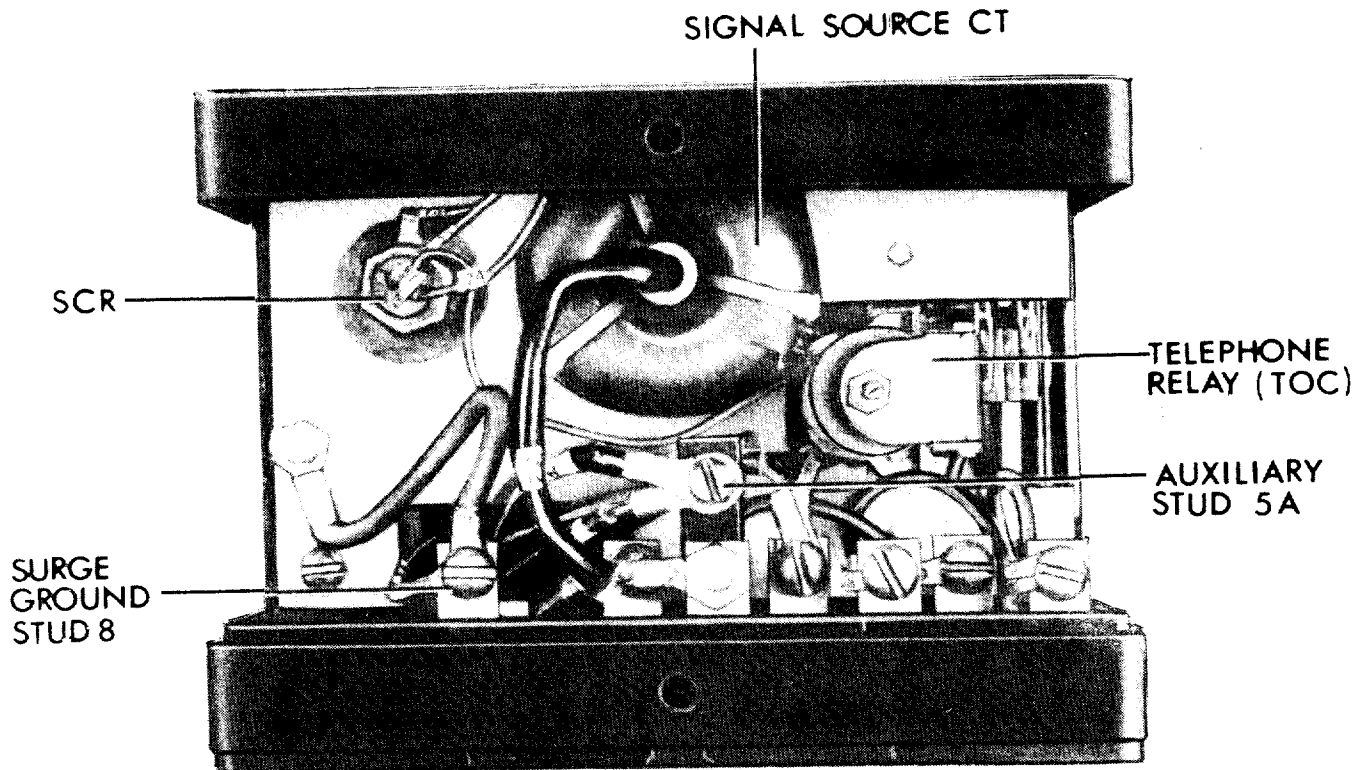

FIGURE 24. (0246A6811 [3]) TEST CONNECTIONS TYPE SFC RELAY



SFC RELAY - FRONT VIEW
(REMOVED FROM CASE)

FIGURE 25. (8918138B) SFC RELAY - FRONT VIEW (REMOVED FROM CASE)



SFC RELAY - REAR VIEW
(REMOVED FROM CASE)

FIGURE 26. (8918138C) SFC RELAY - REAR VIEW (REMOVED FROM CASE)

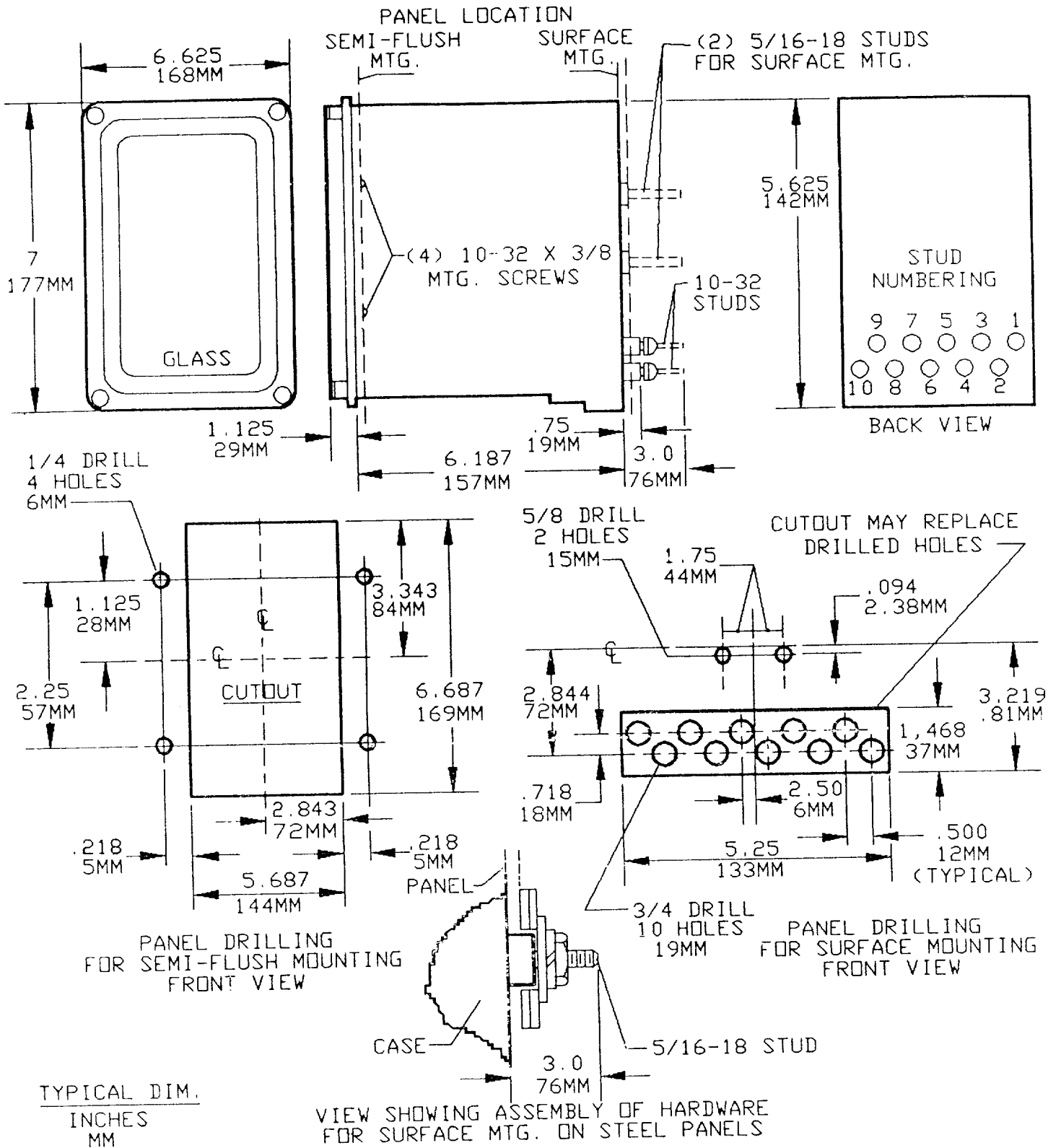
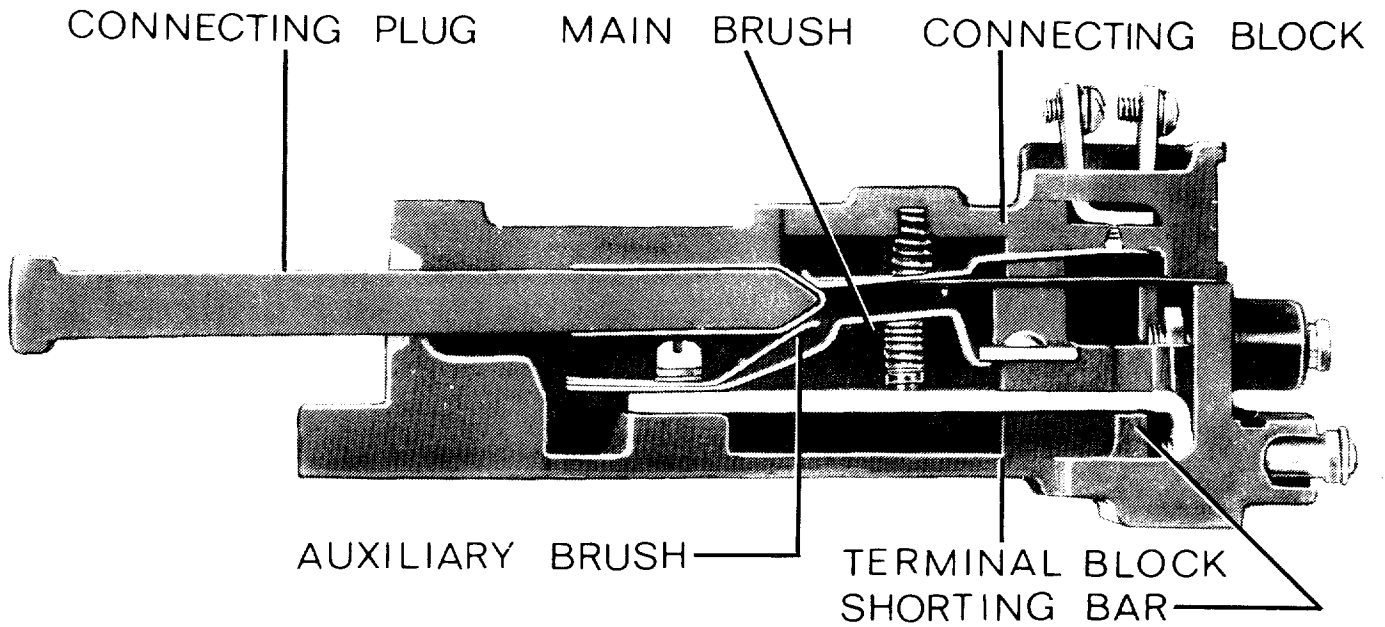

FIGURE 27. (0246A7968-6) OUTLINE AND PANEL DRILLING DIMENSIONS FOR THE SFC RELAY



NOTE: AFTER ENGAGING AUXILIARY BRUSH CONNECTING PLUG TRAVELS $\frac{1}{4}$ INCH BEFORE ENGAGING THE MAIN BRUSH ON THE TERMINAL BLOCK

FIGURE 28. (8025039) CUTAWAY OF DRAWOUT CASE SHOWING POSITION OF AUXILIARY BRUSH AND SHORTING BAR



GE Power Management

**215 Anderson Avenue
Markham, Ontario
Canada L6E 1B3
Tel: (905) 294-6222
Fax: (905) 201-2098
www.ge.com/indsys/pm**